



ENCORE
POWER EQUIPMENT



DGE
Pro

EE52FX691V34P
EE60FX730V34P

PARTS MANUAL



ENCORE
POWER EQUIPMENT
ENCOREEQUIPMENT.COM

 **401 COMMERCE STREET**
BEATRICE, NE 68310

 **800-267-4255**

 **402-223-4103**

CONTENTS

CASTER ASSEMBLY	4
ROPS ASSEMBLY	5
FRAME ASSEMBLY	6
CLUTCH STOP ASSEMBLY.....	8
SEAT ASSEMBLY.....	9
MOTION CONTROL ASSEMBLY.....	10
MOTION CONTROL SUB ASSEMBLY	11
REAR TIRE ASSEMBLY.....	12
PARK BRAKE ASSEMBLY	13
DECK LIFT ASSEMBLY	14
52” DECK WITH DECALS.....	16
60” DECK WITH DECALS.....	17
52” DECK ASSEMBLY	18
60” DECK ASSEMBLY	20
SPINDLE HOUSING	22
HYDRO IDLER W/ PULLEY ASSEMBLY... 	23
DECK IDLER ASSEMBLY	24
DECK IDLER.....	25
HYDRO ASSEMBLY	26
FUEL ASSEMBLY.....	28
ENGINE ASSEMBLY FX691.....	30
ENGINE ASSEMBLY FX730.....	31
BATTERY GROUP.....	32
WIRING DIAGRAM	33
DECALS - SAFETY & OPERATION.....	34
DECALS - BRANDING	35

CASTER ASSEMBLY

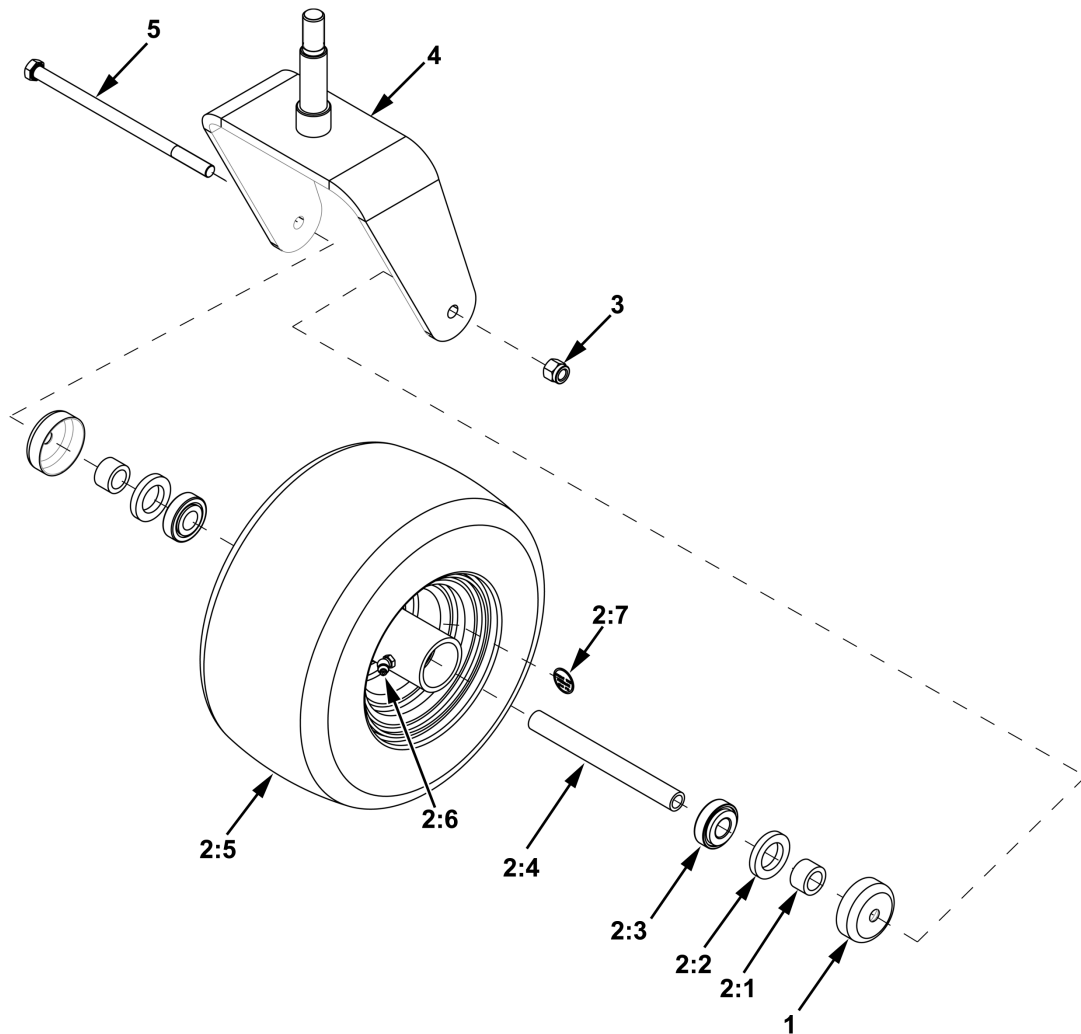

ITEM	PART NUMBER	DESCRIPTION
1	520206	CAP, DUST
2	542070	ASM, COMPLETE WHEEL
2:1	5202035 ¹	BUSHING .78
2:1	633295 ¹	BUSHNIG .53
2:2	5202036	SEAL, LIP
2:3	5202037	BEARING, TAPPED ROLLER
2:4	543230	TUBE, AXLE
2:5	542007	TIRE, 13 X 6.5-6 PNEUMATIC
2:6	453389	DECAL, FRONT TIRE PRESSURE
3	B6182-12	NUT, NYLOC M12
4	542011-2	WLD, CASTER FORK 6.5, RED
5	543189	BOLT, M12 225 MM

¹MOWERS ARE PRODUCED USING EITHER ITEM, THE ONLY DIFFERENCE BEING LENGTH, MEASURE OLD ONE TO ENSURE CORECT ITEM BEFORE ORDERING

ROPS ASSEMBLY

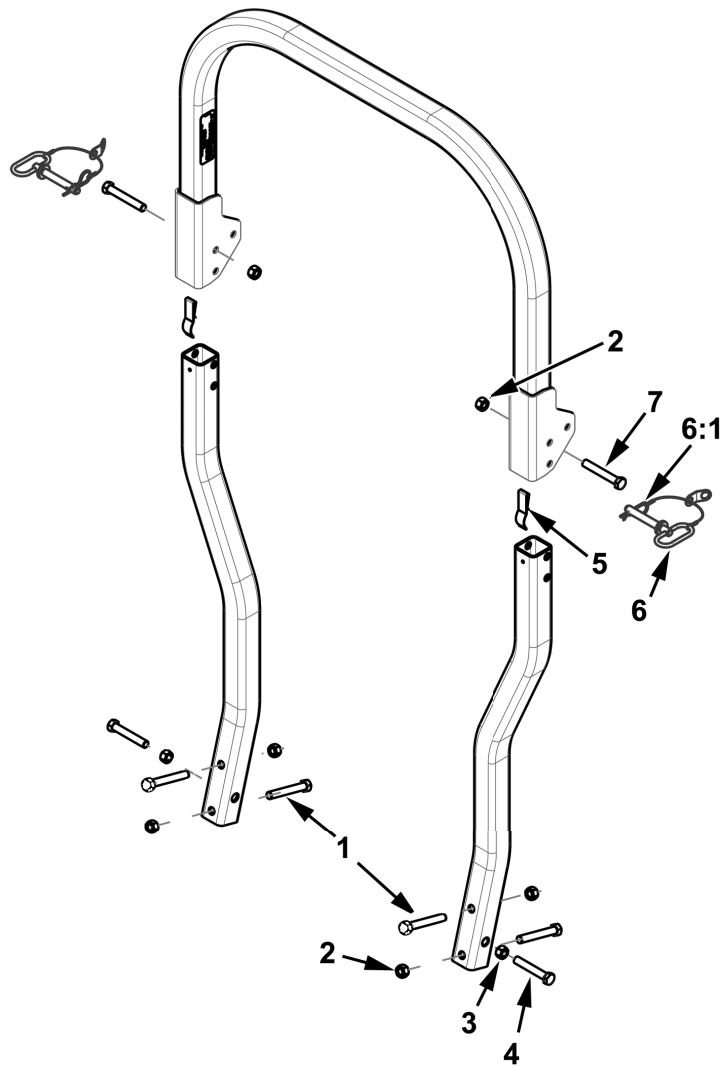

ITEM	PART NUMBER	DESCRIPTION
	632031	COMPLETE ROPS ASSEMBLY
1	100334 ¹	1/2-13 X 3-1/2 HHCS
2	104259	1/2-13 HEX NYLOC NUT
3	104509	1/2-13 REG HEX NUT
4	100049	SCREW, HH TAP 1/2-13 X 3
5	633152	SPRING, ROPSV
6	543262	PIN, ROPS W/LANYARD
6:1	153025	#4 HAIRPIN COTTER
7	100332	SCREW, HH 1/2-13 X 3-1/4

¹TORQUE TO 75 FT-LBS

FRAME ASSEMBLY

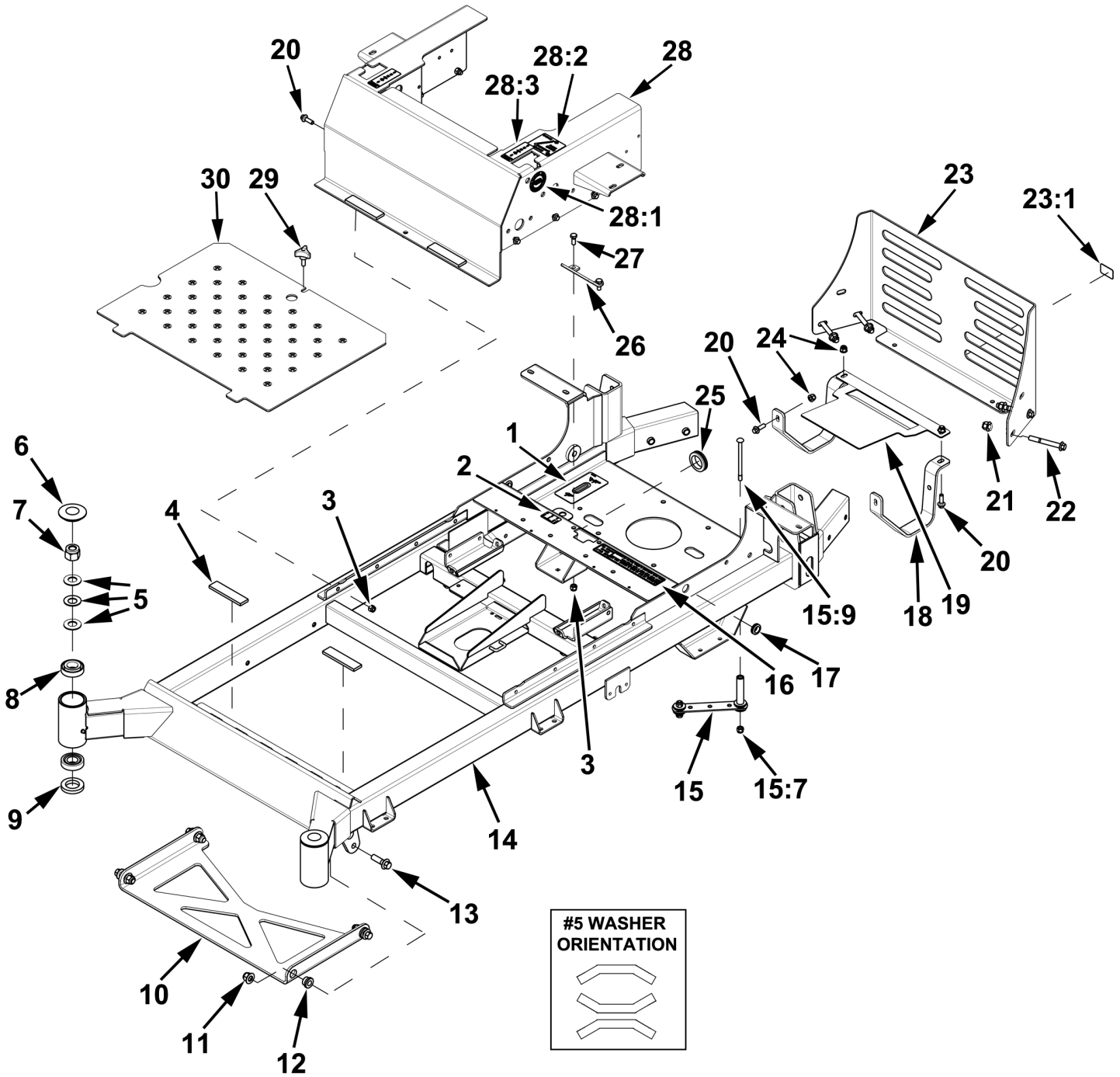

ITEM	PART NUMBER	DESCRIPTION
1	633306	DECAL, HYDRO RELEASE
2	543433	DECAL, FUEL VALVE
3	B6182-8	NUT, NYLOC M8
4	363201	PAD, RUBBER
5	B1972-A40	WASHER, SPRING DISC A40
6	5202009	CAP, DUST
7	B6182-20	NUT, NYLOC M20
8	B297-30205	BEARING 30205
9	B13871-B32528	SEAL (F) 32 X 52 X 8
10	633010-2	PLATE, FRONT STRUT – RED
11	B6183-12	NUT, FLANGE NYLOC M12
12	453288	BUSHING
13	B5787-1240	SCREW, HH FLANGED M12-40
14	632024	FRAME, W/DECALS
15	632036	ASM, CLUTCH STOP DETAILED ON PAGE 8
15:7	B6182-8	NUT, NYLOC M8
15:9	B801-8110	BOLT, CARRIAGE SN M8 X 110
16	43396	DECAL, HYDRO RESERVOIR
17	5002030	BUSHING, RUBBER
18	633234-1	STRAP, MUFFLER GUARD – BLACK
19	633235-1	SHIELD, MUFFLER HEAT – BLACK
20	B5787-825	SCREW, HH FLANGE M8 X 25
21	B6183-10	NUT, NYLOC FLANGE M10
22	B5787-1080	SCREW, FLANGE HEAD M10 X 80
23	632057	ASM, REAR GUARD W/DECAL
23:1	8318	DECAL, MUFFLER TEMP
24	B6183-8	NUT, FLANGE NYLOC M8
25	453382	GROMMET, RUBBER 1-5/16" ID
26	633120	RAMP, SEAT LATCH
27	B5783-820	SCREW, HH TAP M8 X 20
28	632055	ASM, SEAT CONSOLE W/DECALS
28:1	543380	DECAL, MADE IN BEATRICE
28:2	543391	DECAL, PARK BRAKE
28:3	8324	DECAL, MOTION CONTROL
29	633239	KNOB
30	633011-1	PLATE, FOOT – BLACK

CLUTCH STOP ASSEMBLY

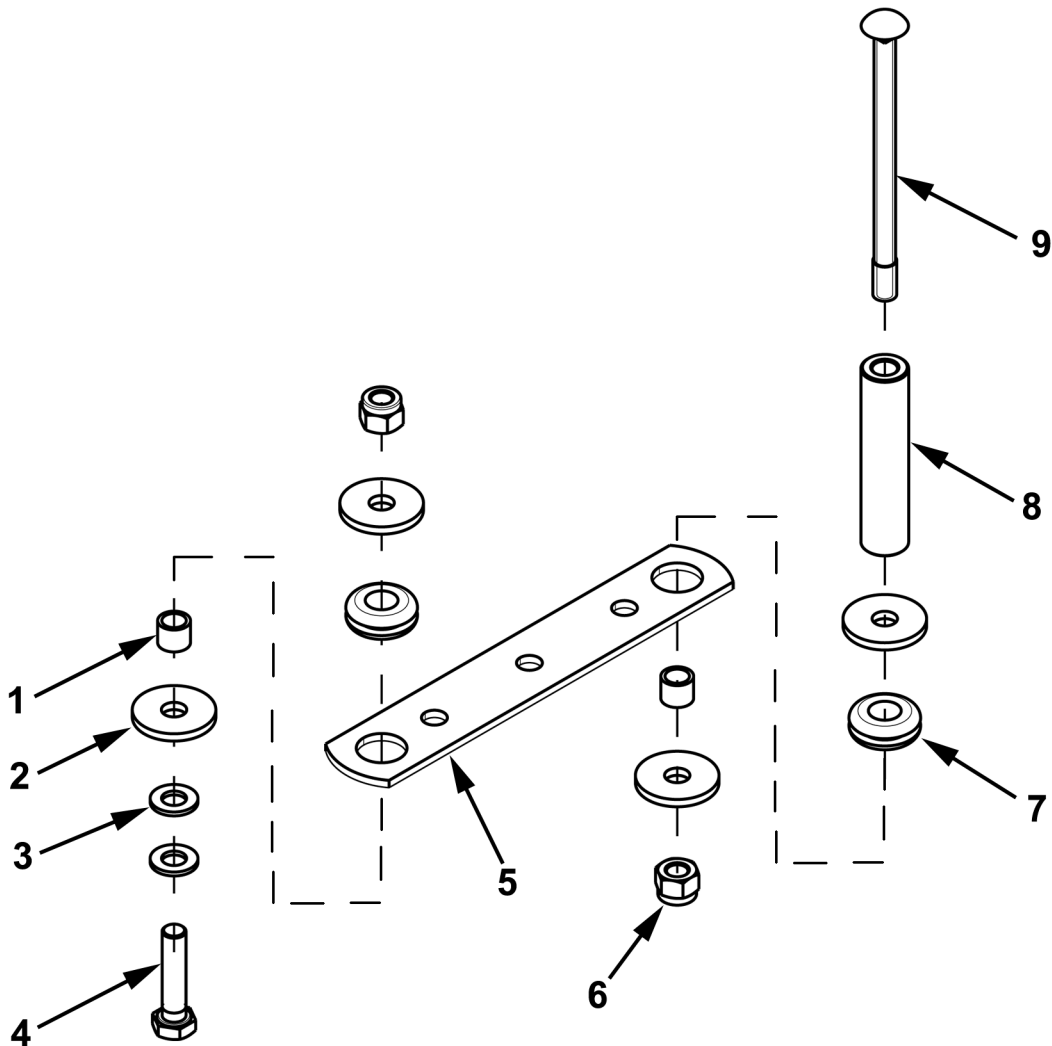

ITEM	PART NUMBER	DESCRIPTION
1	5203409	SPACER, BUSHING
2	5203408	WASHER
3	B97.1-8	WASHER 8
4	B5783-835	SCREW M8 X 35
5	5203411	STRAP, CLUTCH STOP
6	B6182-8	NUT, NYLOC M8
7	5203410	RING, RUBBER 17
8	633118	SPACER, TUBE
9	B801-8110	BOLT, CARRIAGE SN M8 X 110

SEAT ASSEMBLY

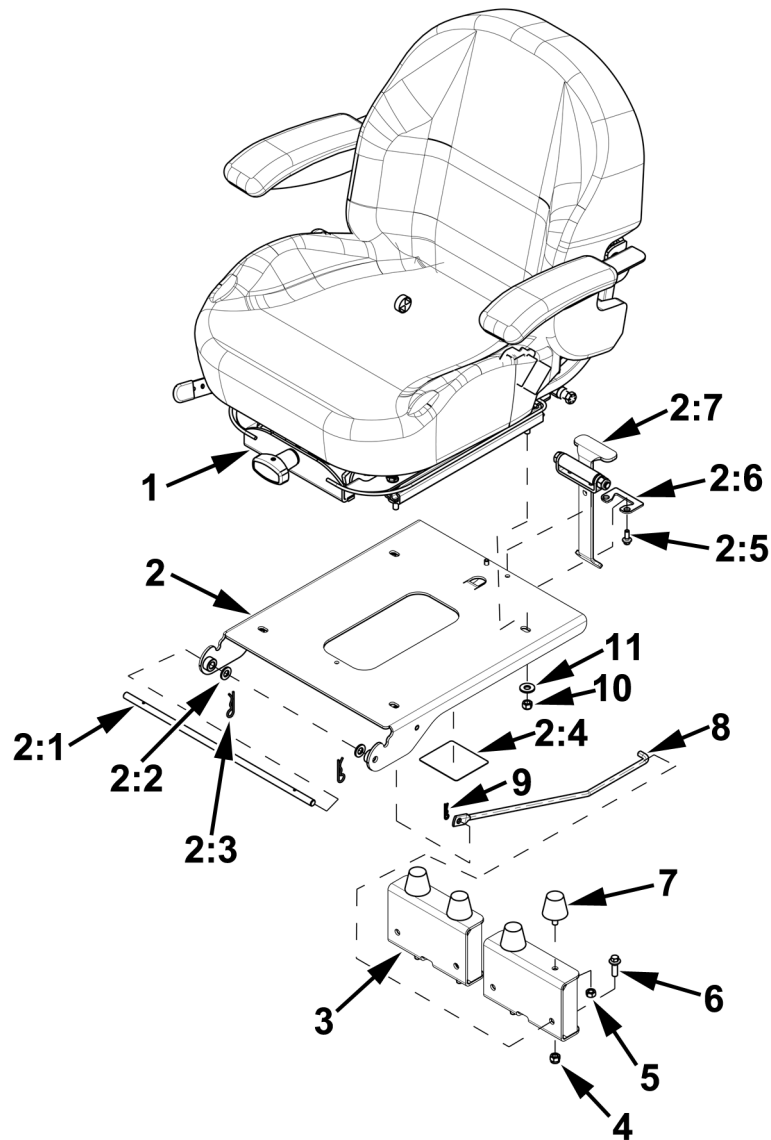

ITEM	PART NUMBER	DESCRIPTION
1	633356	SEAT 1110, FULL SUP MB
-	353048	SWITCH, SEAT
2	634071	GRP, SEAT PAN
2:1	633111	ROD, SEAT
2:2	B97.1-10	WASHER, FLAT M10
2:3	363166	COTTER, HAIRPIN
2:4	543397	DECAL, BATTERY WARNING
2:5	B5787-616	SCREW, HH FLANGE M6 X 16
2:6	633370	STOP, SEAT LATCH
2:7	632131	WLD, SEAT LATCH
3	632130-1	WLD, SEAT BRACKET – BLACK

MOTION CONTROL ASSEMBLY

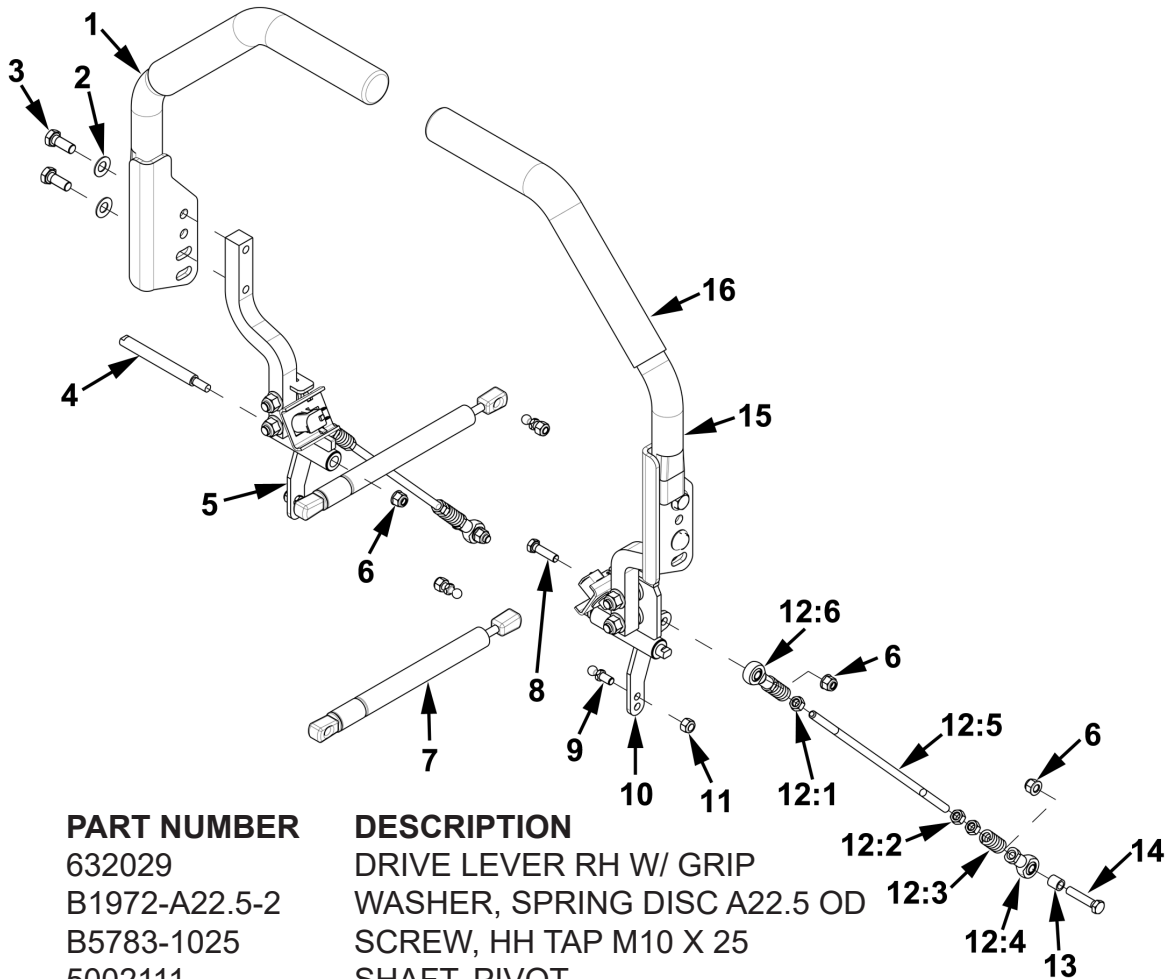

ITEM	PART NUMBER	DESCRIPTION
1	632029	DRIVE LEVER RH W/ GRIP
2	B1972-A22.5-2	WASHER, SPRING DISC A22.5 OD
3	B5783-1025	SCREW, HH TAP M10 X 25
4	5002111	SHAFT, PIVOT
5	632010	ASM, MOTION CONTROL RH DETAIL ON PG 11
6	B6183-8	NUT, FLANGED NYLOC M8
7	583415	DAMPENER, CONTROL
8	B5783-830	SCREW, HH TAP M8 X 30
9	823221	STUD, BALL 10MM
10	632009	ASM, MOTION CONTROL LH DETAIL ON PG 11
11	104256	NUT, HEX NYLOC 5/16-18
12	632030	ASM, HYDRO LINKAGE
12:1	B6171-8L	NUT, LH M8X1
12:2	B6171-8	NUT M8
12:3	5205003	SPRING, COMPRESSION
12:4	5205016	ROD END, SPHERICAL M8 RH SIBJK8S
12:5	633088	ROD, MOTION CONTROL LINKAGE
12:6	5205017	ROD END, SPHERICAL M8 LH SILBJK8S
13	633042	SPACER
14	B5783-840	SCREW, HH TAP M8 X 40
15	632028	DRIVE LEVER LH W/ GRIP
16	543156	GRIP, MOTION CONTROL LEVER

MOTION CONTROL SUB ASSEMBLY

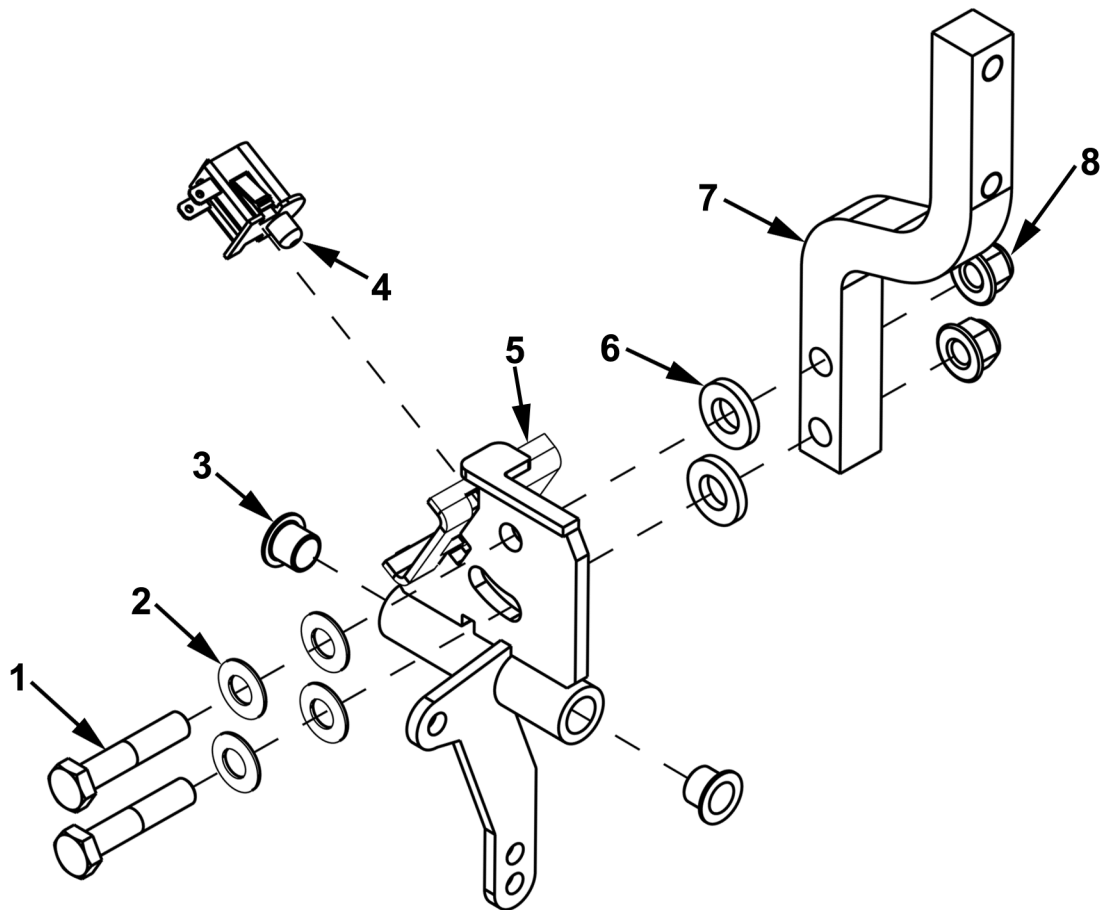

ITEM	PART NUMBER	DESCRIPTION
1	B5782-1050	SCREW, HH M10 X 50
2	B1972-A22.5-2	WASHER, SPRING DISC A22.5 OD
3	543154	BUSHING, MOTION CONTROL
4	353048	SWITCH, SEAT
5	632011	WLD, MOTION CONTROL LH
	632012	WLD, MOTION CONTROL RH
6	543152	WASHER, PLASTIC
7	633025	ARM, MOTION CONTROL
8	B6183-10	NUT, NYLOC FLANGE M10

REAR TIRE ASSEMBLY

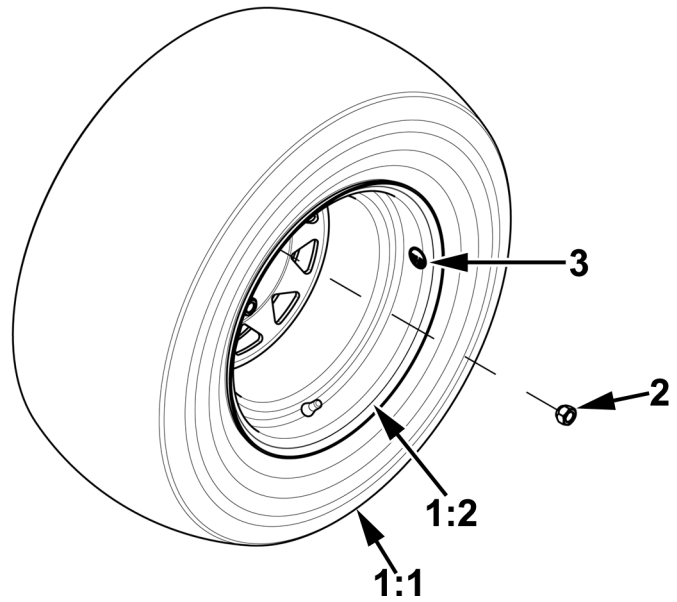
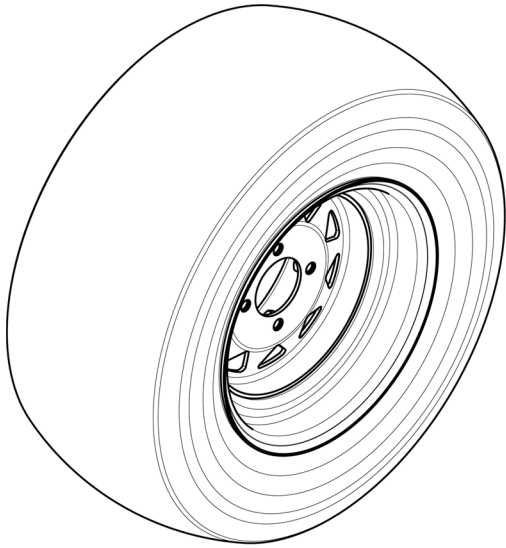

ITEM	PART NUMBER	DESCRIPTION
1	5200001	ASM, DRIVE WHEEL ZTR
1:1	5200011	CARLISLE TURF MATE 23X10.5-12
1:2	5200012	RIM, DRIVE WHEEL
2	103023	NUT, KUG 1/2-20 X 60 T
3	453390	DECAL, REAR TIRE PRESSURE

PARK BRAKE ASSEMBLY

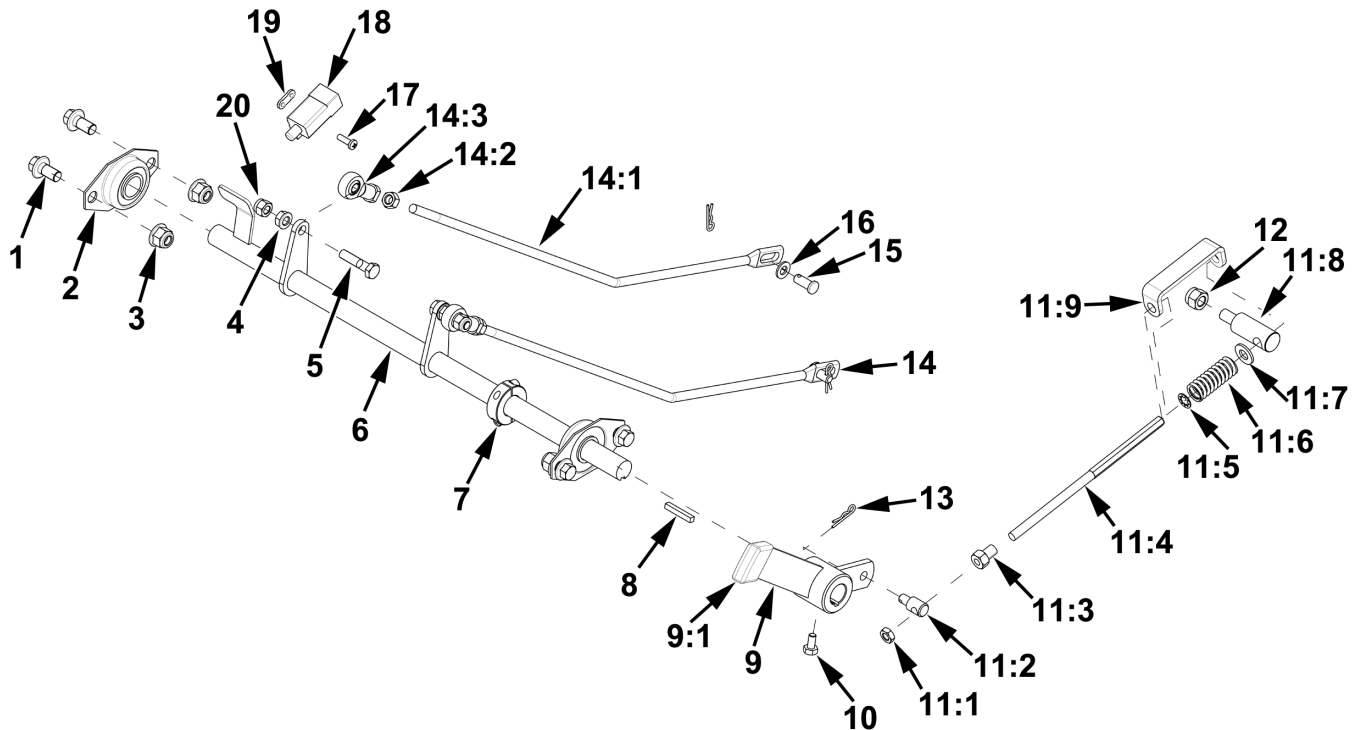

ITEM	PART NUMBER	DESCRIPTION
1	B5787-1020	SCREW, HH FLANGED M10 X 20
2	423140	BEARING, 2 BOLT 3/4" ID
3	B6183-10	NUT, NYLOC FLANGE M10
4	B6177-8	NUT, WHIZLOCK M8
5	B5782-835	SCREW, M8 X 35
6	632013-1	SHAFT-BRAKE -BLACK
7	523138	COLLAR, CLAMP 3/4"
8	107264	KEY, MACHINE 3/16 X 3/16 X 1-1/4
9	632015	ASM, BRAKE LEVER
9:1	543300	GRIP, PARK BRAKE
10	100501	SCREW, HH 1/2 X 1/4-28
11	462082	ASM, BRAKE SPRING
11:1	104751	NUT, HEX JAM 5/16-18
11:2	463231	SWIVEL, PARK BRAKE ROD
11:3	593116	NUT, BRAKE SPRING - PLATED
11:4	463089	ROD, SHORT BRAKE
11:5	363117	WASHER, STAR 3/8"
11:6	523024	SPRING, COMPRESSION
11:7	105259	WASHER, FLAT SAE 3/8"
11:8	633116	SWIVEL, PARK BRAKE
11:9	593114	STRAP, PARK BRAKE - PLATED
12	B6182-10	NUT, NYLOC M10
13	XSZ56-1-17	PIN, HAIR
14	632019	ASM, BRAKE LINK
15	B882B-820	PIN, CLEVIS 8 X 20
16	B97.1-8	WASHER 8
17	B823-516	SCREW, M5 X 16
18	523034	SWITCH
19	5208108	ROCK, NUT
20	B6182-8	NUT, NYLOC M8

DECK LIFT ASSEMBLY

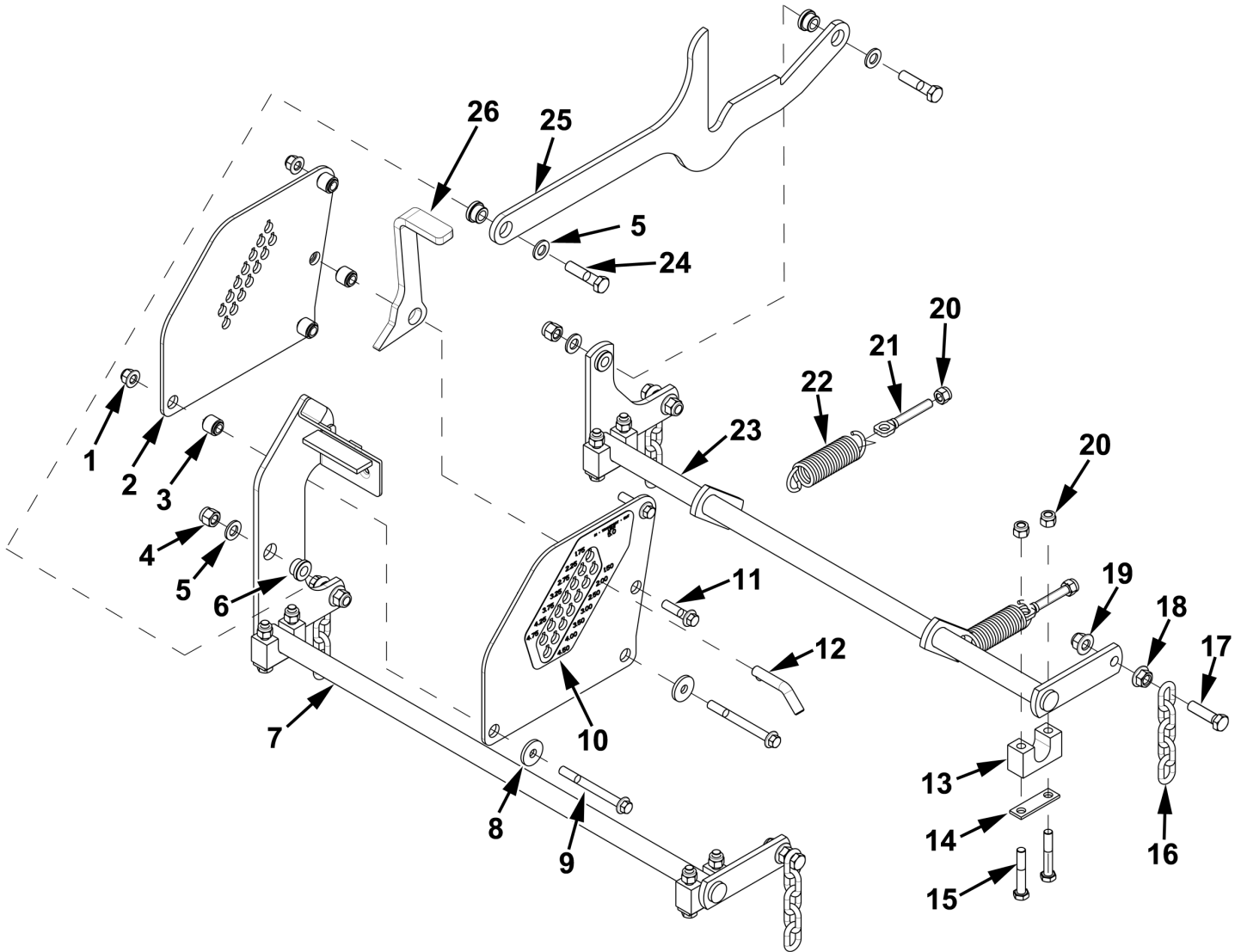

ITEM	PART NUMBER	DESCRIPTION
1	B6183-10	NUT, NYLOC FLANGE M10
2	633028-1	PLATE, HOC – BLACK
3	633032	SPACER, HOC
4	B6182-12	NUT, NYLOC M12
5	B97.1-12	WASHER 12
6	453288	BUSHING
7	632004-1	WLD, FT CROSS SHAFT – BLACK
8	5201083	SPACER
9	B5787-10100	SCREW, HH FLANGED M10 X 100
10	633106	DECAL, DECK HEIGHT
11	B5787-1040	SCREW, HH FLANGE M10 X 40
12	543207	PIN, HOC
13	633119	BLOCK, 25MM PIVOT
14	633220-1	PLATE, 25MM PIVOT BLOCK
15	B5782-1060	SCREW, HH M10 X 60
16	423359	CHAIN, - 5 LINKS
17	B5782-1245	SCREW, HH M12 X 45
18	B6177-12	NUT, FLANGE M12
19	B6183-12	NUT, NYLOC FLANGE M12
20	B6182-10	NUT, NYLOC M10
21	2802083B	ROD, CONNECTING
22	523327 S	PRING, TENSION
23	632005-1	WLD, REAR CROSS SHAFT – BLACK
24	B5782-1250	SCREW, HHCS M12 X 50
25	633027-1	LINK, DECK LIFT – BLACK
26	633031	LATCH, TRANSPORT

52" DECK WITH DECALS

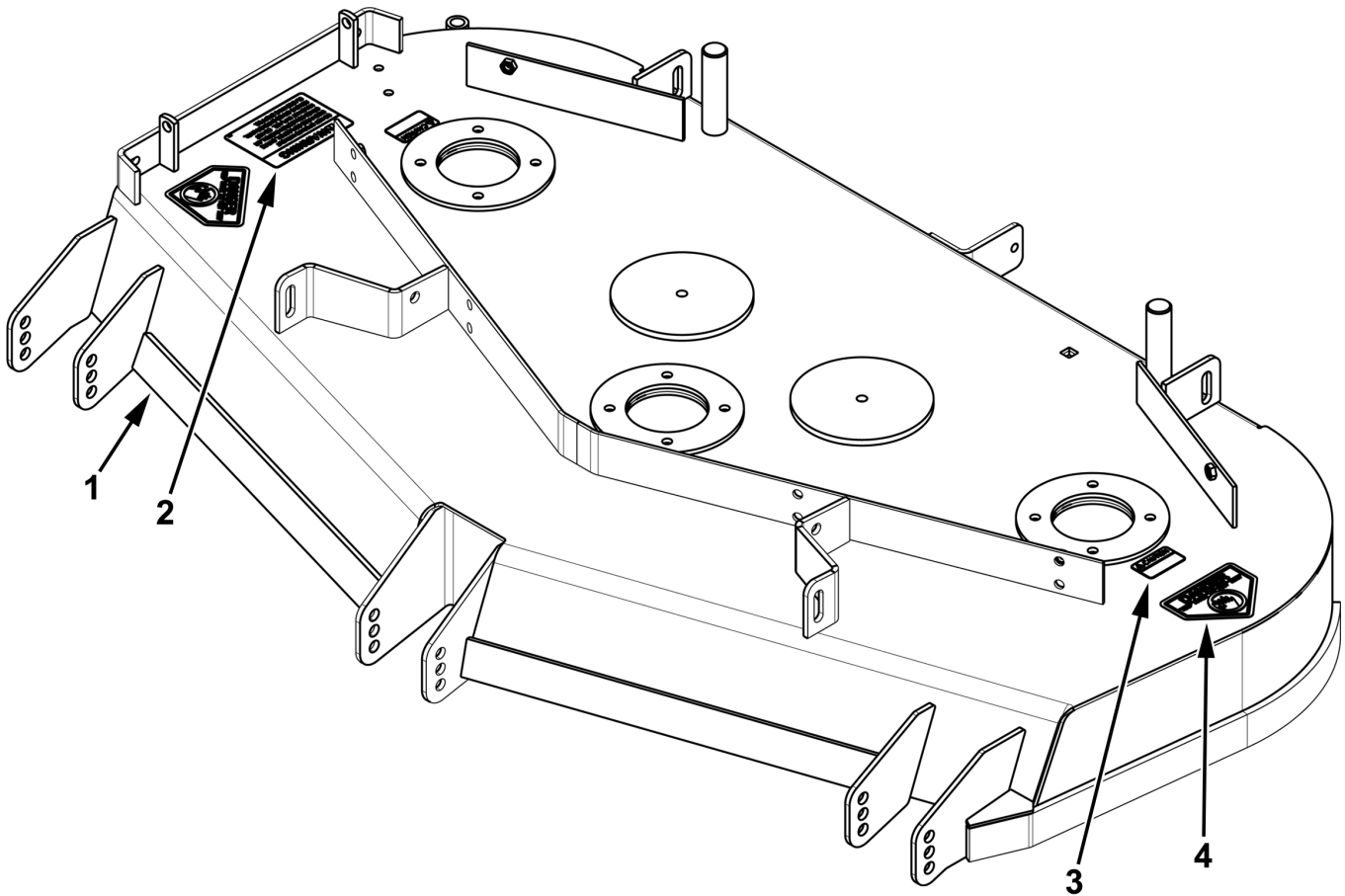

ITEM	PART NUMBER	DESCRIPTION
-	632050	ASM, 52 DECK W/ DECALS
1	632001-2	WLD, 52 DECK – RED
2	8307	DECAL, DISCHARGE WARNING
3	8303	DECAL, CAUTION, GUARDING SM
4	363023	DECAL, DANGER HANDS AND FEET

60" DECK WITH DECALS

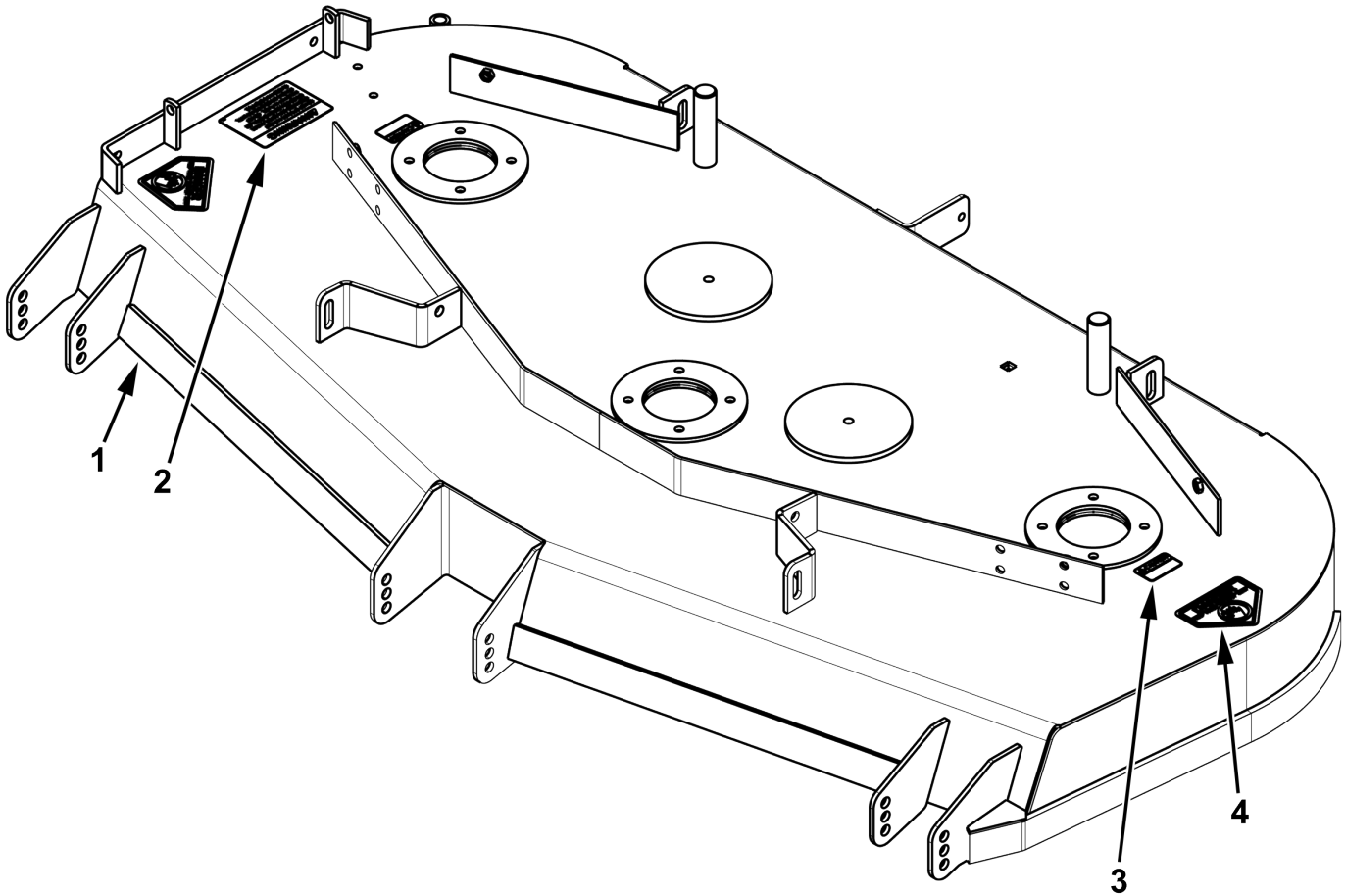

ITEM	PART NUMBER	DESCRIPTION
-	632090	ASM. 60 DECK W/DECALS
1	632042-2	WLD, 60" DECK – RED
2	8307	DECAL, DISCHARGE WARNING
3	8303	DECAL, CAUTION, GUARDING SM
4	363023	DECAL, DANGER HANDS AND FEET

52" DECK ASSEMBLY

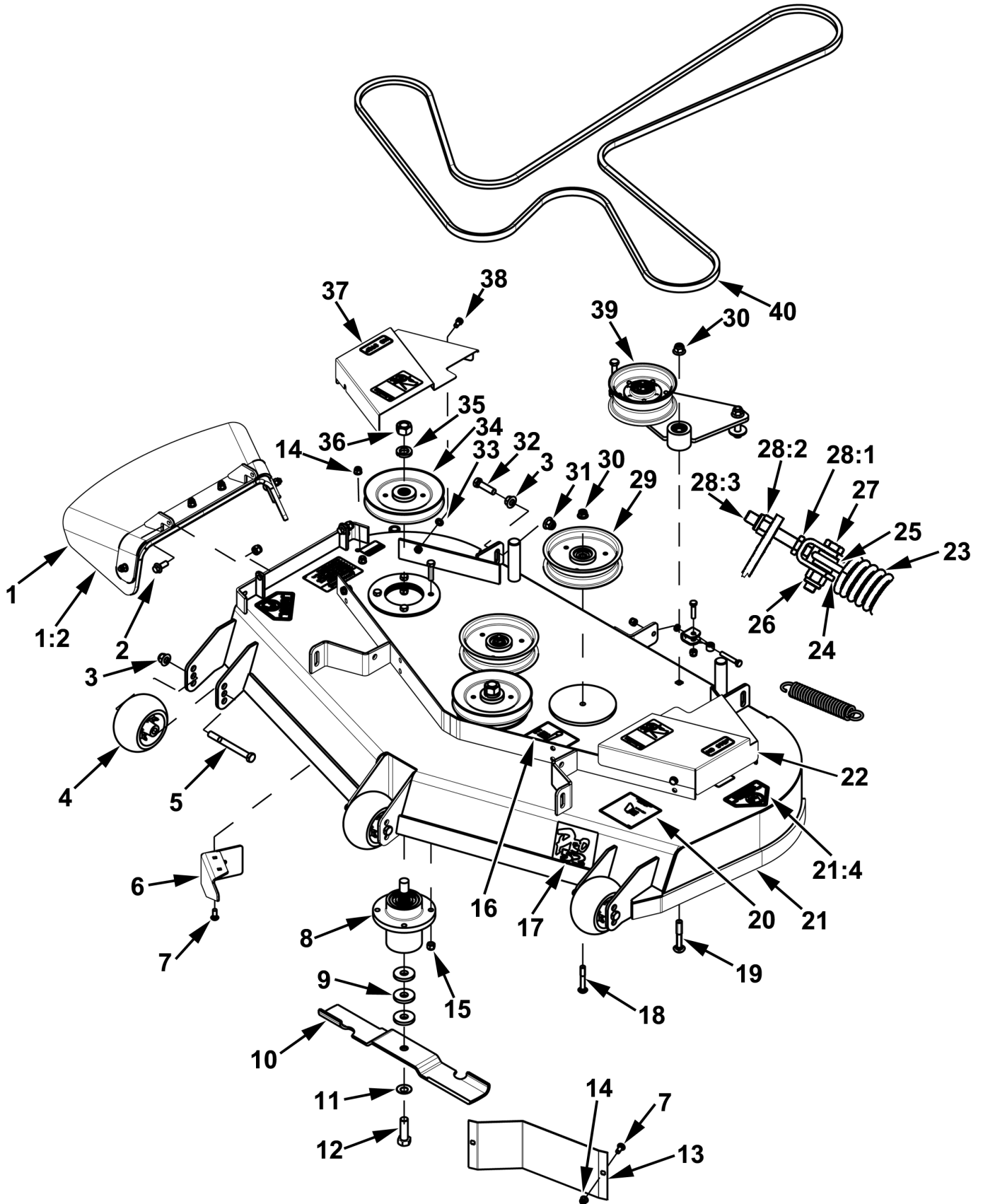

ITEM	PART NUMBER	DESCRIPTION
1	6001053	DISCHARGE CHUTE (RUBBER)
1:2	6001050A	ASM, DISCHARGE CHUTE 52/60
2	B5787-1025	SCREW, HH FLANGE M10 X 25
3	B6183-12	NUT, NYLOC FLANGE M12
4	543225	ROLLER, ANTI SCALP
5	B5782-12120	SCREW, HH M12 X 120
6	543213	BAFFLE, DOGLEG
7	B801-820	BOLT, CARRIAGE SN M8 X 20
8	583111	SPINDLE HOUSING
9	363382	BLADE SPACER .250 X Ø1.75 PLATED [.63]
10	823004	18" HI LIFT BLADE
11	583108	WASHER, SPRING DISC 5/8
12	100347	SCREW, HH 5/8-11 X 2
13	543046-2	BAFFLE, BIRDWING LH PAINTED - RED
14	B6183-8	NUT, FLANGED NYLOC M8
15	104257	NUT, NYLOC 3/8-16
16	633228	DECAL, BELT ROUTING
17	523493	DECAL, PRO 52
18	B801-1060	BOLT, CARRIAGE M10 X 60
19	B801-1270	CARRIAGE BOLT M12 X 70
20	543392	DECAL, ANTI SCALP ROLLER
21	632050	ASM, 52" DECK W/DECALS
21:4	363023	DECAL, DANGER HANDS AND FEET
22	632046	SHIELD, LH 52 BELT, W/DECALS
23	5207015	SPRING, IDLER PULLEY
24	633300	YOKE
25	633301	BUSHING
26	B6182-8	NUT, NYLOC M8
27	B5783-835	SCREW, M8 X 35
28	632124	ASM, YOKE
28:1	B6172-8	NUT, THIN HEX M8
28:2	B6177-12	NUT, FLANGED M12
28:3	B5783-850	SCREW, HH M8 X 50
29	542138	IDLER, FLAT 150MM DETAIL PG 25
30	B6187-10	NUT, NYLOC FLANGE M10
31	B6177-12	NUT, NYLOC FLANGE M12
32	B5783-1245	SCREW, HH TAP M12 X 45
33	B97.1-8	WASHER 8
34	452073	PULLEY, DECK
35	105010	LOCKWASHER ¾
36	104511	NUT, HEX UNF ¾-16
37	632047	SHIELD, RH 52 BELT, W/DECALS
38	B5783-816	SCREW, HH TAP M8 X 16
39	632034	ASM, DECK IDLER DETAIL PG 24
40	633068	BELT, DECK

60" DECK ASSEMBLY

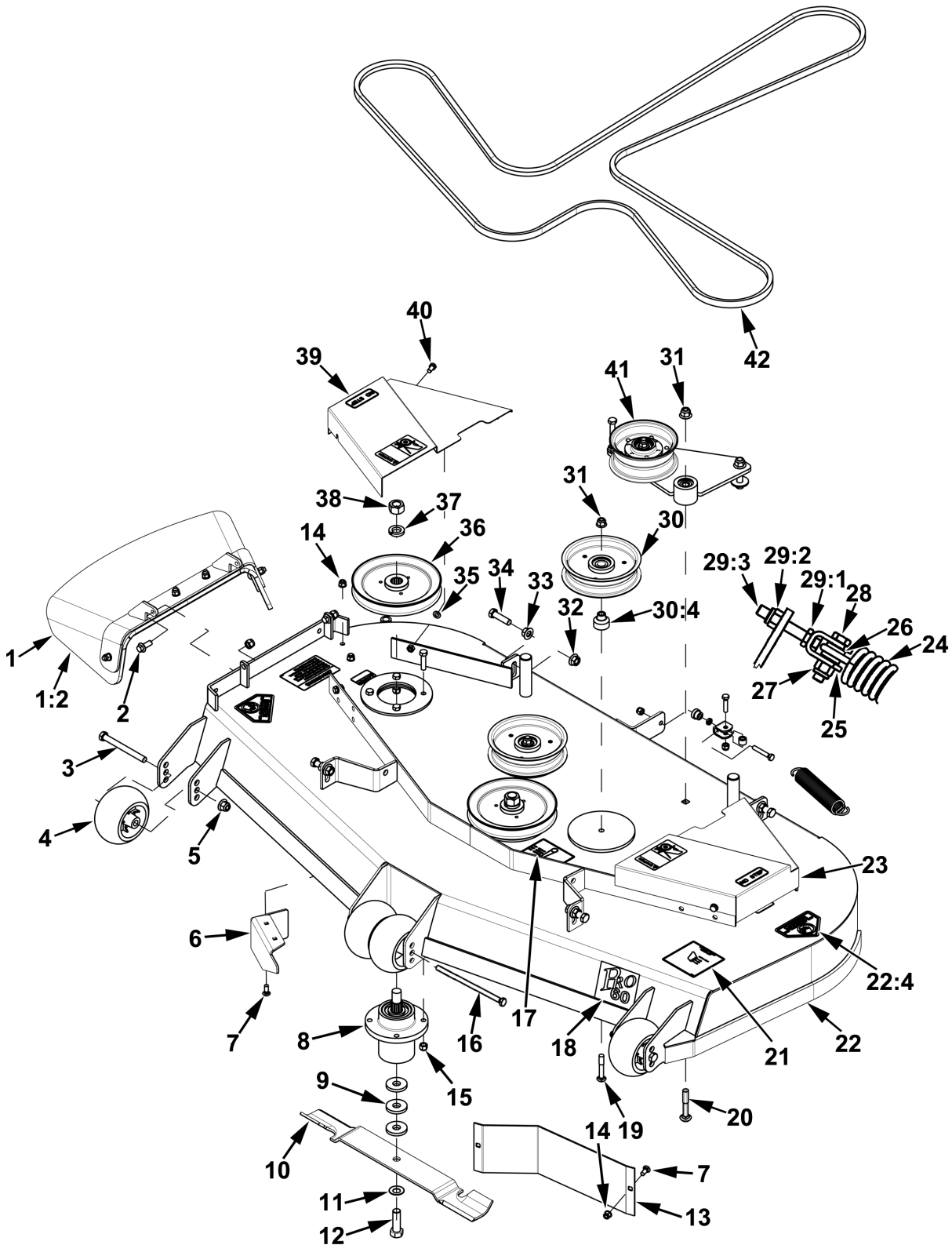

ITEM	PART NUMBER	DESCRIPTION
1	6001053	DISCHARGE CHUTE (RUBBER)
1:2	6001050A	ASM, DISCHARGE CHUTE 52/60
2	B5787-1025	SCREW, HH FLANGE M10 X 25
3	B5782-12120	SCREW, HH M12 X 120
4	543225	ROLLER, ANTI SCALP
5	B6183-12	NUT, NYLOC FLANGE M12
6	543213	BAFFLE, DOGLEG
7	B801-820	BOLT, CARRIAGE SN M8 X 20
8	583111	SPINDLE HOUSING
9	363382	BLADE SPACER .250 X Ø1.75 PLATED [.63]
10	633335	BLADE, 20-1/2" HI LIFT
11	583108	WASHER, SPRING DISC 5/8
12	100347	SCREW, HH 5/8-11 X 2
13	543046-2	BAFFLE, BIRDWING LH PAINTED - RED
14	B6183-8	NUT, FLANGED NYLOC M8
15	104257	NUT, NYLOC 3/8-16
16	5202029	SCREW, HH CAP M12 X 185
17	633228	DECAL, BELT ROUTING
18	543402	DECAL, PRO 60
19	B801-1060	BOLT, CARRIAGE M10 X 60
20	B801-1270	CARRIAGE BOLT M12 X 70
21	543392	DECAL, ANTI SCALP ROLLER
22	632090	ASM, 60" DECK W/DECALS
22:4	363023	DECAL, DANGER HANDS AND FEET
23	632091	SHIELD, LH 60 BELT, W/DECALS
24	633382	SPRING, IDLER PULLEY
25	633300	YOKE
26	633301	BUSHING
27	B6182-8	NUT, NYLOC M8
28	B5783-835	SCREW, M8 X 35
29	632124	ASM, YOKE
29:1	B6172-8	NUT, THIN HEX M8
29:2	B6177-12	NUT, FLANGED M12
29:3	B5783-850	SCREW, HH M8 X 50
30	542138	IDLER, FLAT 150MM DETAIL PG 25
30:4	543450	SPACER, IDLER
31	B6187-10	NUT, NYLOC FLANGE M10
32	B6183-12	NUT, NYLOC FLANGE M12
33	B6177-12	NUT, FLANGE M12
34	B5783-1245	SCREW, HH TAP M12 X 45
35	B97.1-8	WASHER 8
36	452073	PULLEY, DECK
37	105010	¾ LOCKWASHER
38	104511	¾-16 UNF REG HEX NUT
39	632092	SHIELD, RH 60 BELT, W/DECALS
40	B5783-816	SCREW, HH TAP M8 X 16
41	632034	ASM, DECK IDLER DETAIL PG 24
42	633338	BELT, 60" DECK

SPINDLE HOUSING

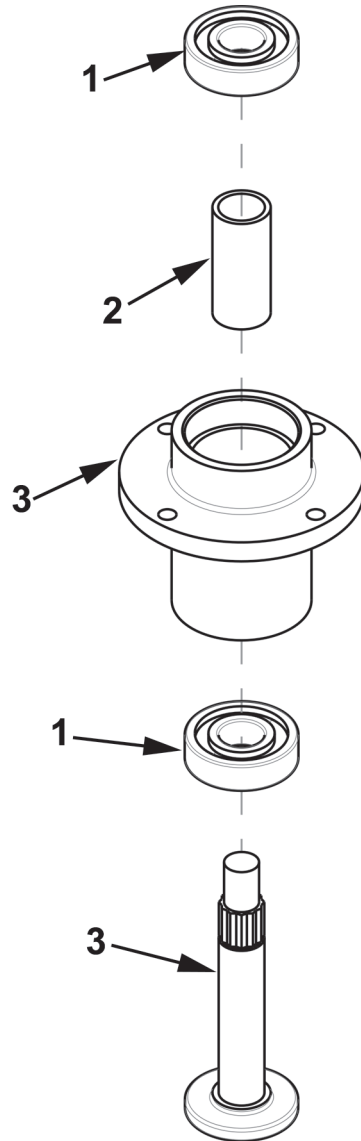

ITEM	PART NUMBER	DESCRIPTION
-	583106	BLADE SPINDLE ASSY
1	363350	BEARING - BLADE SPINDLE
2	583113	BEARING SPACER TUBE
3	583111	SPINDLE HOUSING
4	583112	SPINDLE SHAFT

HYDRO IDLER W/ PULLEY ASSEMBLY

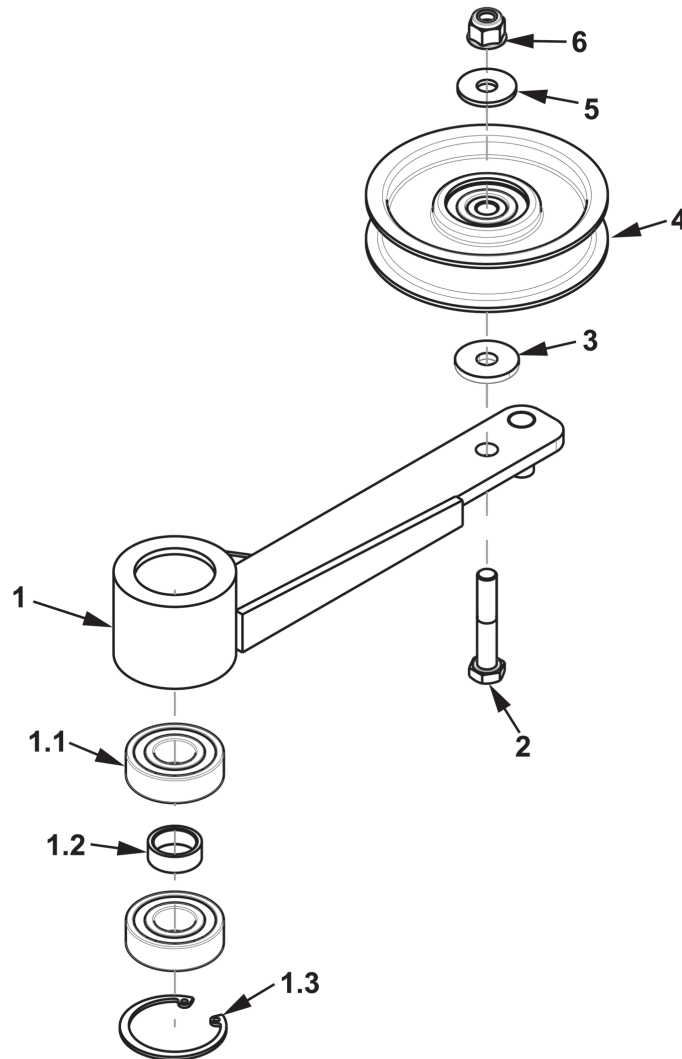

ITEM	PART NUMBER	DESCRIPTION
-	632017	ASM, HYDRO IDLER W/PULLEY
1	632022	ASM, HYDRO IDLER
1.1	B276-6203RS	BEARING 6203-2RS
1.2	5201077	BUSHING
1.3	B893.1-40	RING, SNAP 40
2	B5782-845	SCREW, HH M8 X 45
3	3303034	WASHER 8
4	633302	PULLEY, 3.37 X .75 IDLER
5	B97.1-12	WASHER 12
6	B6183-12	NUT, FLANGE NYLOC M12

DECK IDLER ASSEMBLY

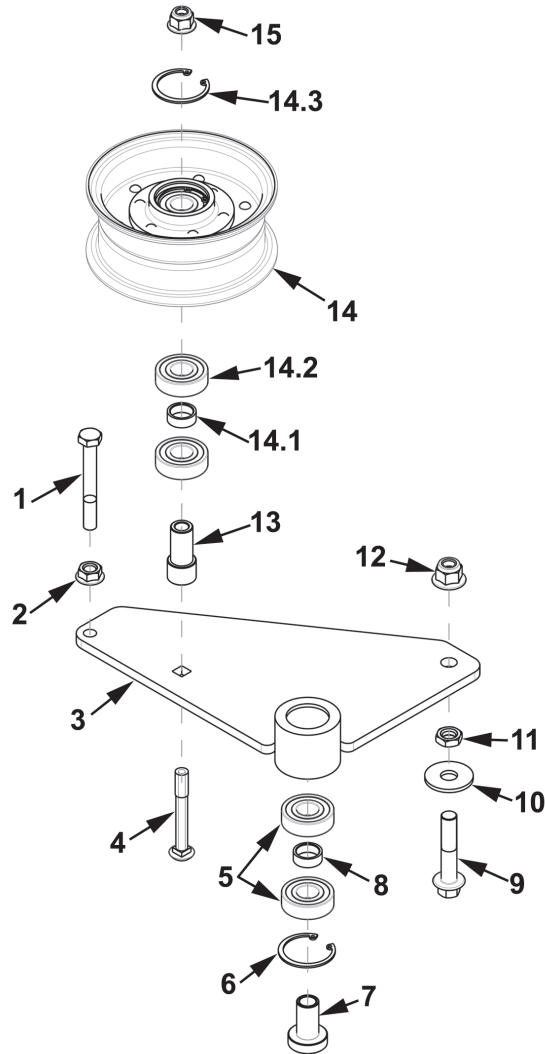

ITEM	PART NUMBER	DESCRIPTION
-	632034	ASM, DECK IDLER
1	B5782-1080	SCREW, HH M10 X 80
2	B6177-10	NUT, FLANGE M10
3	632033	WLD, DECK IDLER ARM
4	B801-1075	BOLT, CARRIAGE M10 X 75
5	B276-6203RS	BEARING, 6203-2RS
6	B893.1-40	RING, SNAP 40
7	633015	SPACER, STEPPED
8	5201077	BUSHING
9	B5787-1260	SCREW, HH FLANGE M12 X 60
10	B96-12	WASHER, FLAT LARGE M12
11	B6172.1-12	NUT, JAM M12
12	B6183-12	NUT, FLANGE NYLOC M12
13	463220	SPACER, IDLER PULLEY
14	462072	ASM, IDLER PULLEY
14.1	5201077	BUSHING
14.2	B276-6203RS	BEARING, 6203-2RS
14.3	B893.1-40	RING, SNAP 40
15	B6183-10	NUT, FLANGE NYLOC M10

DECK IDLER

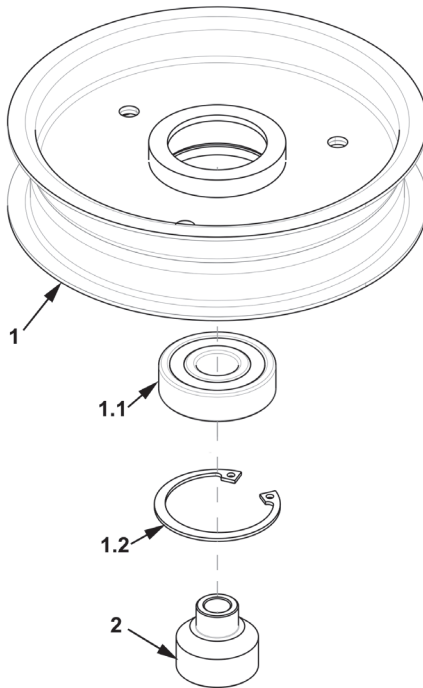

ITEM	PART NUMBER	DESCRIPTION
1	542138	ASM, IDLER FLAT 150MM W/BEARING
1.1	B276-6303RS	BEARING 6303-2RS
1.2	B893.1-47	RING, SNAP 47
2	543450	STAND-OFF, LARGE IDLER

HYDRO ASSEMBLY

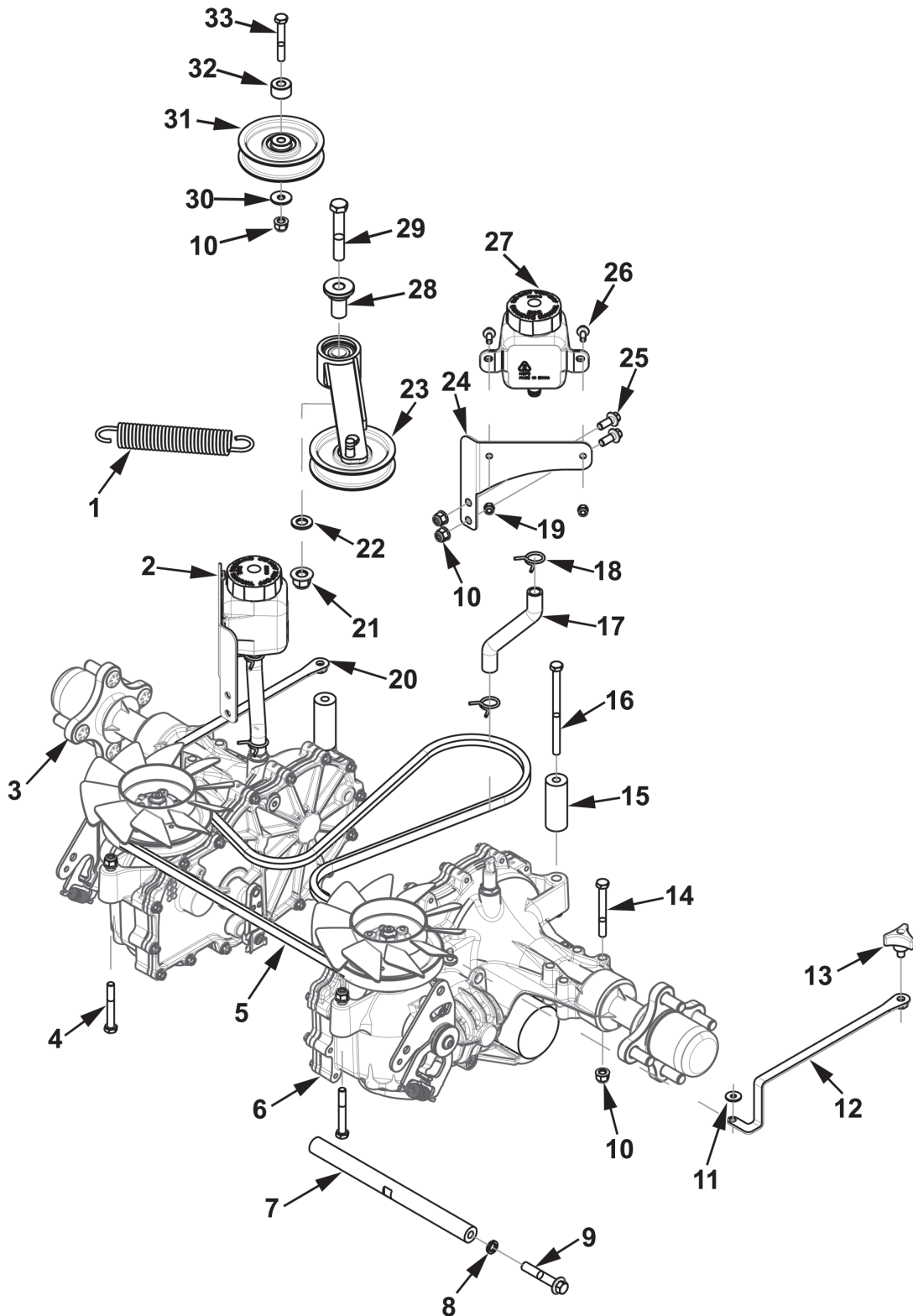

ITEM	PART NUMBER	DESCRIPTION
1	543520	EXENSION SPRING
2	633067-1	BRACKET, HYDRO TANK RH -BLACK
3	543211	HYDRO, ZT3400 RH
4	B5782-860	SCREW, HH M8 X 60
5	633061	BELT, HYDRO
6	543210	HYDRO ZT3400 LH
7	633249	ROD, HYDRO SUPPORT 20MM
8	B93-10	WASHER, LOCK SPLIT M10
9	B5787-1055	SCREW, HH M10 X 55
10	B6183-8	NUT, NYLOC M8
11	B96-6	WASHER, FLAT LARGE M6
12	632021	WLD, HYDRO RELEASE LH
13	3302190	KNOB, 3- PRONGED W/STUD
14	B5782-870	SCREW, HH M8 X 20
15	633030	SPACER, HYDRO
16	B5782-8120	SCREW, HH M8 X 120
17	633272	HOSE, EXP TANK MOLDED
18	633273	CLAMP, WIRE 11/16"
19	B6182-6	NUT, NYLOC M6
20	632020	WLD, HYDRO RELEASE RH
21	B6183-12	NUT, NYLOC FLANGE M12
22	B97.1-12	WASHER 12
23	632017	ASM, IDLER ARM W/PULLEY DETAILED ON PG 23
24	633066-1	BRACKET, HYDRO TANK LH – BLACK
25	B5787-820	SCREW, HH FLANGE M8 X 20
26	B5787-616	SCREW, HH FLANGE M6 X 16
27	6012021	TANK, EXPANSION
28	453313	BUSHING, STEPPED
29	B5782-845	SCREW, HH M8 X 45
30	B96-8	WASHER, M8
31	633302	PULLEY, 3.375 X .75 IDLER
32	633108	SPACER
33	B5782-855	SCREW, HH M8 X 55

FUEL ASSEMBLY

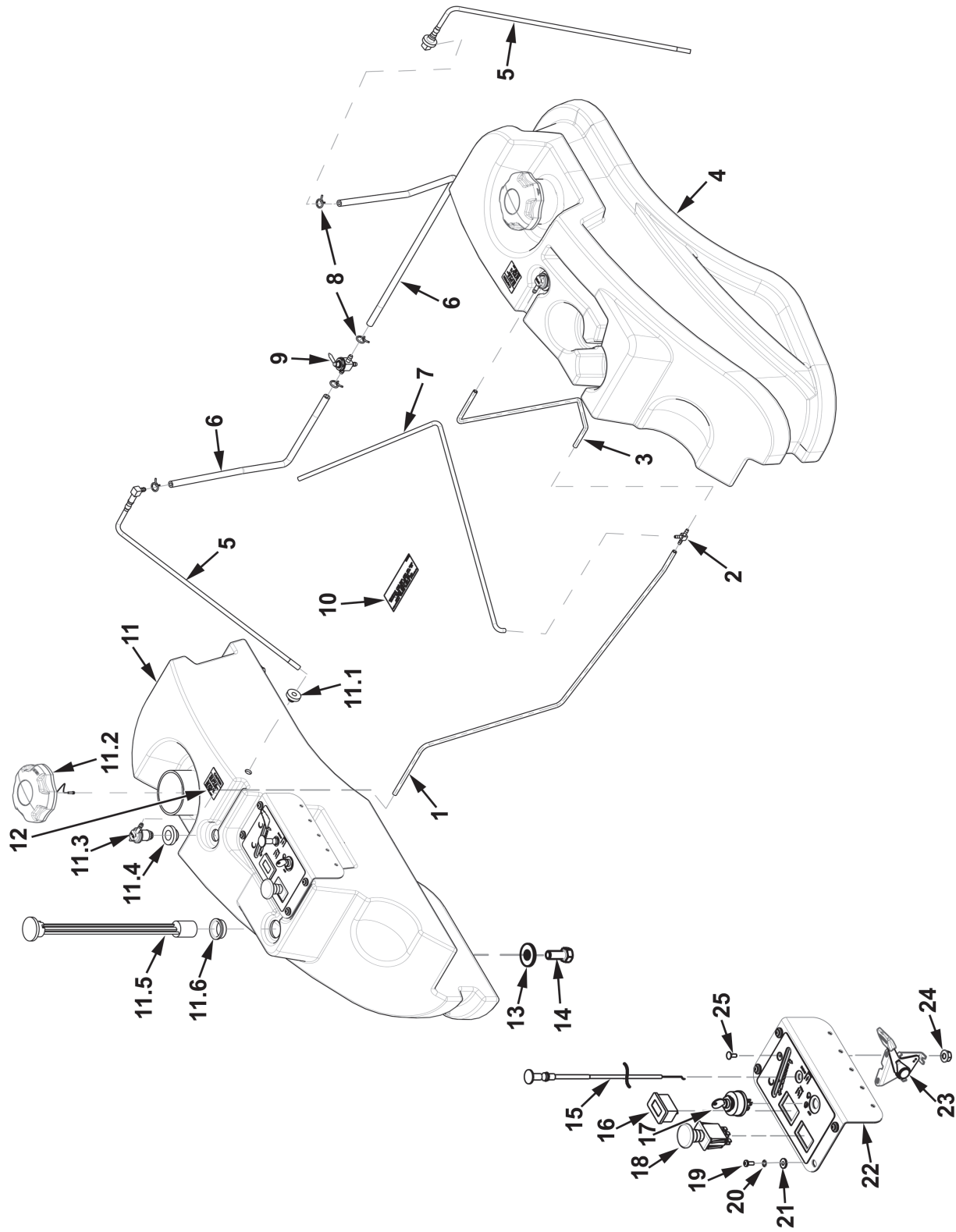

ITEM	PART NUMBER	DESCRIPTION
1	543362	HOSE, VENT 3/16 ID X 36"
2	5204010	TEE, HOSE 3/16 ID
3	353223	HOSE, VENT 3/16 ID X 22"
4	632126	ASM, FUEL TANK LP-LH
5	633308	PICKUP, FUEL 22"
6	633317	HOSE, FUEL 1/4 ID X 28"
7	633102	HOSE, VENT 3/16 X 29"
8	363098	CLAMP, FUEL LINE 1/4 ID
9	583050	VALVE, FUEL
10	533159	LABEL, EPA
11	632125	ASM, FUEL TANK LP-RH
11.1	533125	GROMMET, VALVE -VITON
11.2	363413	CAP, FUEL
11.3	593370	VENT, REMOTE
11.4	363412	GROMMET, VENT VALVE
11.5	633307	GAGE, FUEL 14.5"
11.6	633326	GROMMET, FUEL GAGE
12	544004	LABEL, FUEL WARNING
13	105258	WASHER, FLAT
14	100271	SCREW, HH 5/16-18 X 3/4"
15	633104	CABLE, CHOKE
16	453417	METER, HOUR MS
17	423027	SWITCH, IGNITION
18	4807005	SWTICH, PTO
19	5204045	SCREW, UNC 10-24 1/2"
20	B961.1-5	WASHER, LOCK INT TOOTH M5
21	5204044	BUSHING
22	633309-1	CONSOLE, TANK
23	633103	CABLE, THROTTLE
24	104252	NUT, HEX NYLOC #10-24
25	107527	BOLT, CARRIAGE #10-24 X 1/2

ENGINE ASSEMBLY FX691

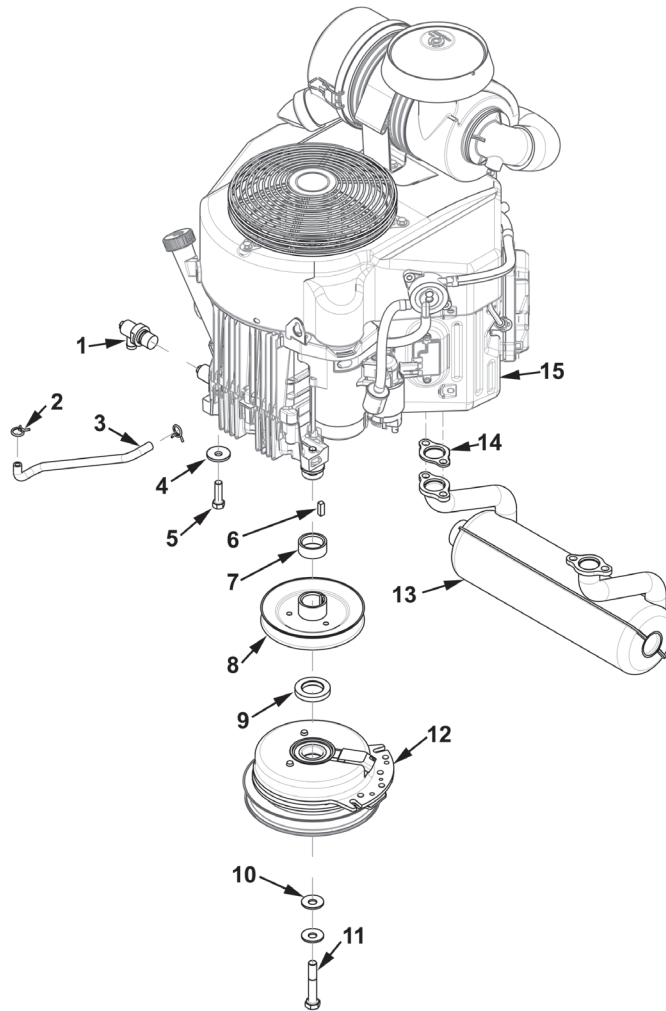

ITEM	PART NUMBER	DESCRIPTION
1	343146	DRAIN, 90° -KAW
2	363098	CLAMP, FUEL LINE 1/4 ID
3	633099	HOSE, FUEL 1/4" X 14"
4	753027	WASHER, SPRING DISC
5	100293	SCREW, HH 3/8-16 X 1-1/4
6	107258	KEY, MACHINE 1/4 X 1/4 X 3/4
7	633038	SPACER, ENGINE
8	543003	SHEAVE, PUMP DRIVE
9	823248	SPACER, CLUTCH 9/32
10	423069	WASHER, SPRING DISC -7/16
11	100535	SCREW, HH 7/16-20 X 2-1/2
12	633073	CLUTCH, 175 LB
13	633033	MUFFLER, KAWASAKI 691
14	483098	GASKET, MUFFLER
15	543239	ENGINE, KAWASAKI FX691

ENGINE ASSEMBLY FX730

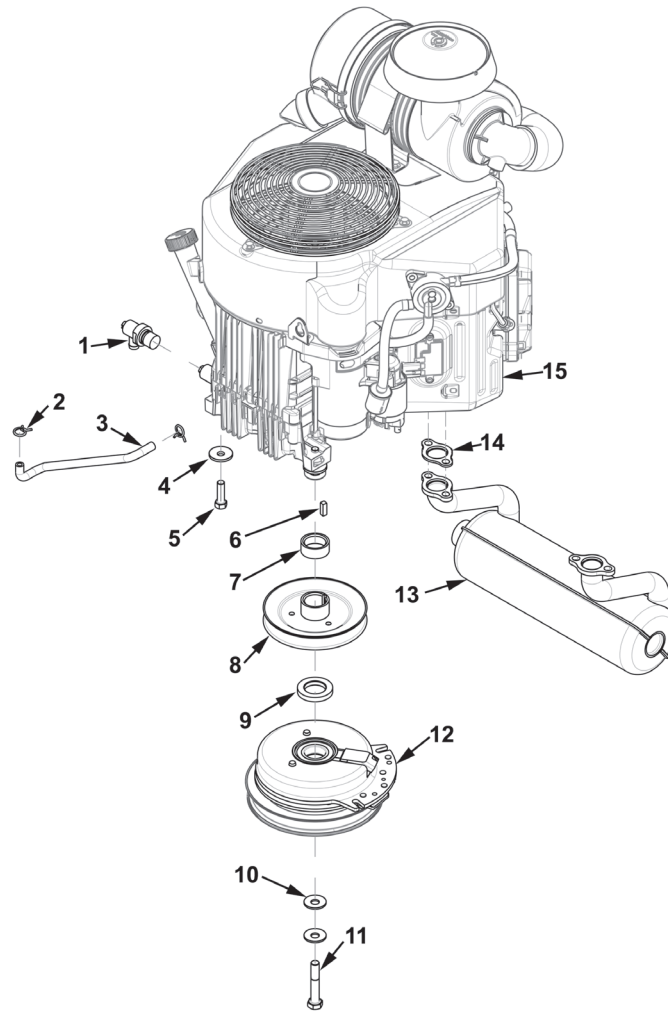

ITEM	PART NUMBER	DESCRIPTION
1	343146	DRAIN, 90° -KAW
2	363098	CLAMP, FUEL LINE 1/4 ID
3	633099	HOSE, FUEL 1/4" X 14"
4	753027	WASHER, SPRING DISC
5	100293	SCREW, HH 3/8-16 X 1-1/4
6	107258	KEY, MACHINE 1/4 X 1/4 X 3/4
7	633038	SPACER, ENGINE
8	543003	SHEAVE, PUMP DRIVE
9	823248	SPACER, CLUTCH 9/32
10	423069	WASHER, SPRING DISC -7/16
11	100535	SCREW, HH 7/16-20 X 2-1/2
12	633073	CLUTCH, 175 LB
13	633033	MUFFLER, KAWASAKI 691
14	483098	GASKET, MUFFLER
15	543240	ENGINE, KAWASAKI FX730

BATTERY GROUP

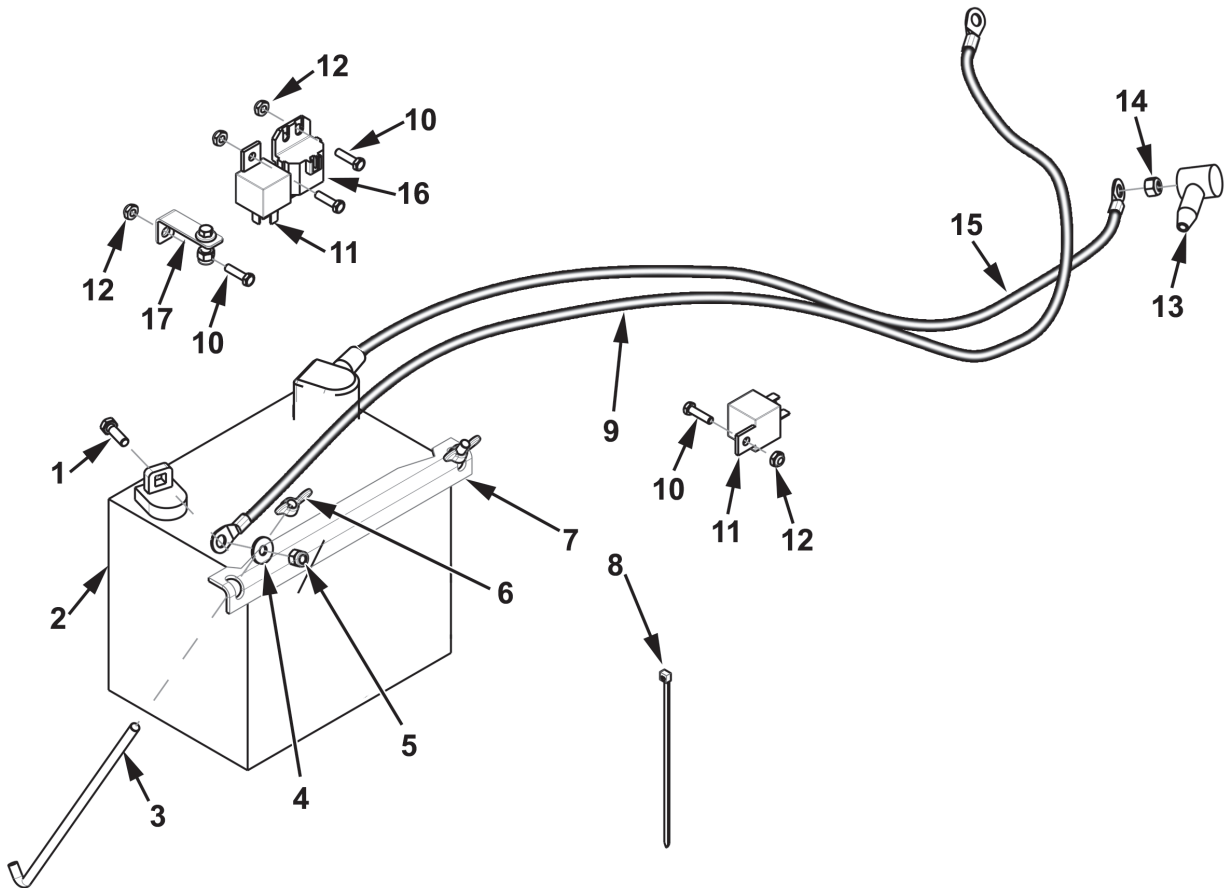

ITEM	PART NUMBER	DESCRIPTION
1	B57873-620	SCREW, HH TAP M6 X 20
2	423142	BATTERY, 12V
3	423172	ROD, BATTERY HOLD DOWN -PLATED
4	B96-6	WASHER, FLAT LARGE M6
5	B6182-6	NUT, NYLOC M6
6	109012	NUT, WING 1/4
7	453419-1	HOLD DOWN, BATTERY -BLACK
8	363222	TIE, PLASTIC
9	543330	CABLE, BATTERY NEGATIVE
10	109009	SCREW, HH #10-24 X 3/4
11	583351	RELAY
12	104252	NUT, NYLOC #10-24
13	2808107	COVER, CABLE
14	104255	NUT, NYLOC 1/4-20
15	4807105	CABLE, BATTERY POSITIVE
16	583423	MODULE, TIME DELAY
17	633379-1	BRACKET, FUSE BOX

WIRING DIAGRAM

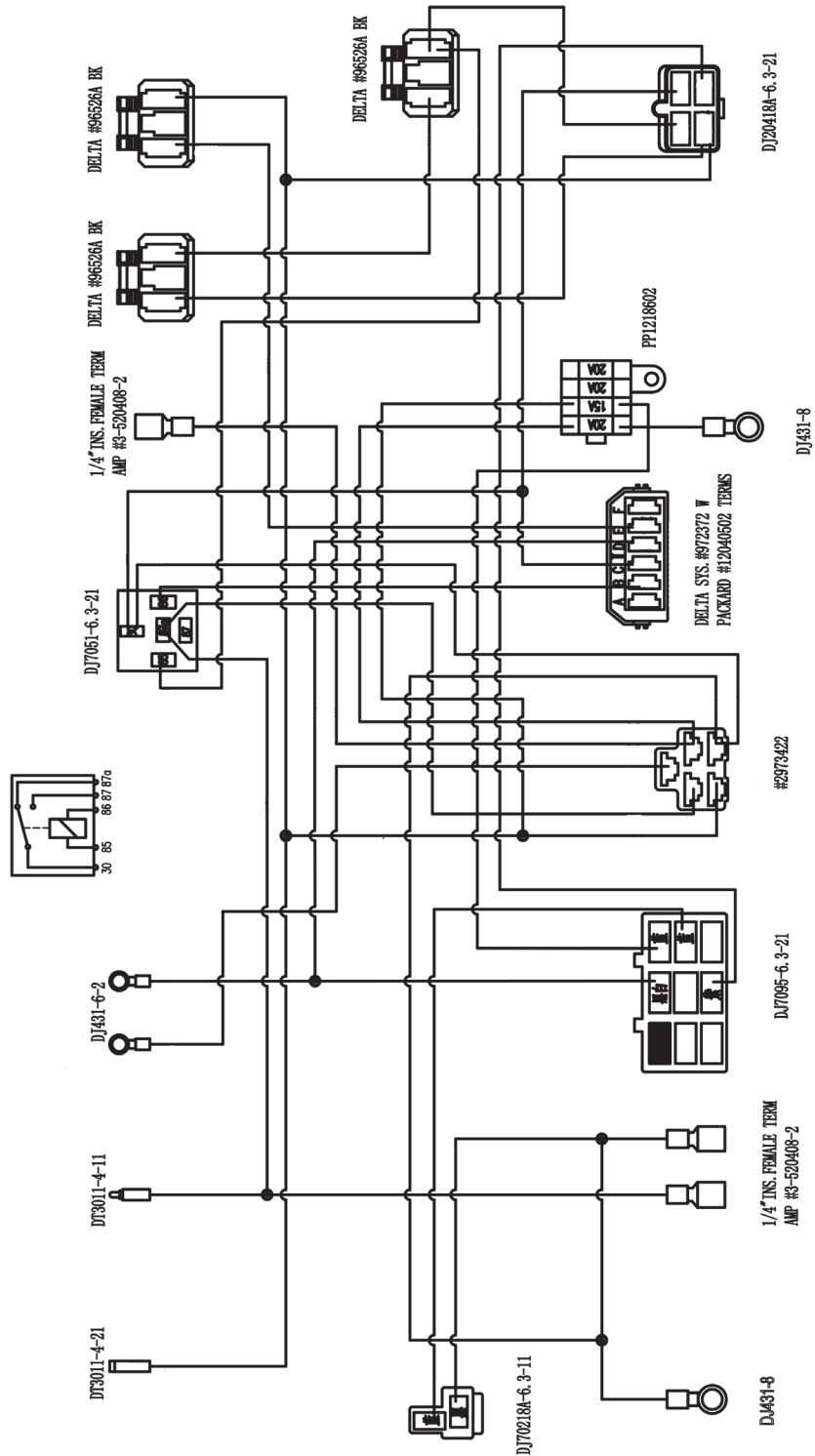

DECALS - SAFETY & OPERATION



8008



8303



8307



543433



543391

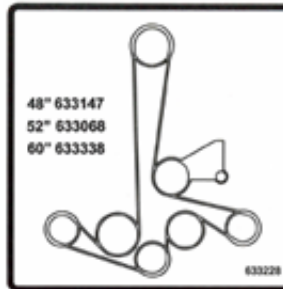

633228



8318



8324



633306



543392



8304



363023

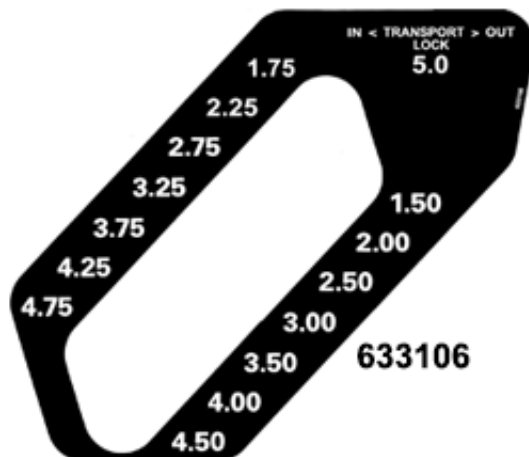

633106

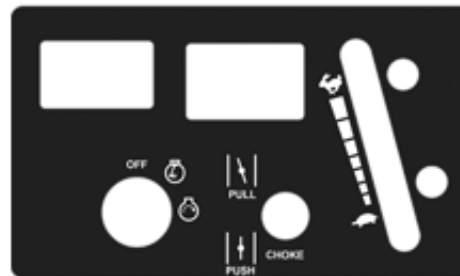

633315



543401



ENCORE

DECALS - BRANDING



633325

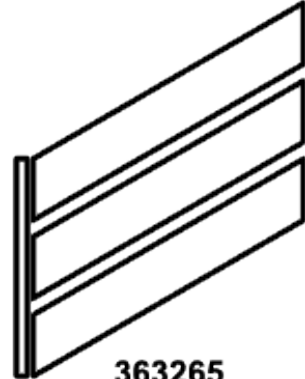

363265



543504



633319

633321



523493



633318

633320



543402

