

Operator's manual & parts catalog



**RSA20N-BS50
POWER-THATCH**



ENCORE EQUIPMENT



Contents

GENERAL OPERATION.....	1
SECTION 1: IMPORTANT SAFE OPERATION PRACTICES.....	4
SECTION 2: LOCATE MODEL AND SERIAL NUMBER.....	4
SECTION 3: SAFTY SPECIFICATIONS.....	4
SECTION 4: ASSEMBLY INSTRUCTIONS.....	5
SECTION 5: FINAL ADJUSTMENTS.....	5
SECTION 6: CONTROLS AND OPERATING.....	7
SECTION 7: MAINTENANCE.....	8
SECTION 8: OFF-SEASON STORAGE.....	10
SECTION 9: TROUBLE SHOOTING GUIDE.....	11
SECTION 10: TECHNICAL DATA.....	11
PARTS CATALOG.....	12



GENERAL OPERATION PRACTICE

· Read this owner's guide carefully in its entirety before attempting to assemble this machine. Read, understand, and follow all instructions on the machine and in the manuals before operation. Be completely familiar with the controls and the proper use of this machine before operating it. Keep this manual in a safe place for future and regular reference and for ordering replacement parts.

· Your power-thatch is a precision piece of power equipment, not a plaything. Therefore, exercise extreme caution always. Your power-thatch has been designed for removing the dead thatch and moss from lawns and other grassed areas.

· Never allow children under 14 years old to operate a power-thatch. Children 14 years old and over should only operate power-thatch under close parental supervision. Only responsible individuals who are familiar with these rules of safe operation should be allowed to use your power-thatch.

· Keep the area of operation clear of all persons, particularly small children and pets. Stop engine when they are near your power-thatch to help prevent blade contact or thrown object injury. Although the area of operation should be completely cleared of foreign objects, an object may have been overlooked and could be accidentally thrown by the power-thatch in any direction and cause serious personal injury to the operator or any others allowed in the area.

PREPARE

· Thoroughly inspect the area where the equipment is to be used. Remove all stones, sticks, wire, bones, toys and other foreign objects which could be picked up and thrown by the power-thatch in any direction and cause serious personal injury to the operator or any others allowed in the area. Plan your mowing pattern to avoid discharge of material toward roads, sidewalks, bystanders and the likes. To help avoid a thrown objects injury, keep children, bystanders and helpers at least 75 feet away from the power-thatch while it is in operation.

· Always wear safety glasses or safety goggles during operation or while performing an adjustment or repair, to protect eyes from foreign objects that may be thrown from the machine in any direction.

· Wear sturdy, rough-soled work shoes and close-fitting slacks and shirts. Shirts and pants that cover the arms and legs and steel-toed shoes are recommended. Do not wear loose fitting clothes or jewelry. They can be caught in moving parts. Never operate a power-thatch in bare feet, sandals,

slippery or light weight (e.g. canvas) shoes.

SAFETY

- Do not operate the power-thatch while under the influence of alcohol or drugs.
- Do not hold bail down while starting engine.
- The drive bail is a safety device. Never attempt to bypass its operation. Doing so makes the safety device inoperative and may result in personal injury through contact with the rotating blade. The blade control handle must operate easily in both directions and automatically return to the disengaged position when released.
- Never operate the power-thatch in wet grass. Always be sure of your footing. A slip and fall can cause serious personal injury. Keep a firm hold on the handle and walk, never run. If you feel you are losing your footing, **RELEASE THE BLADE CONTROL HANDLE IMMEDIATELY** and the blade will stop rotating within three seconds.
- Operate only in daylight or good artificial light.
- Stop the blade when crossing gravel drives, walks or roads.
- If the equipment should start to vibrate abnormally, stop the engine and check immediately for the cause. Vibration is generally a warning of trouble.

MAINTENANCE & STORAGE

- Please follow these recommended maintenance steps from the factory.
- Do not make adjustment, or perform any maintenance until engine is stopped and spark plug wire is disconnected.
- Frequently check engine mounting bolts on your unit for proper tightness.
- Keep engine free from accumulation of grass, leaves or excessive grease. An accumulation of these combustible materials may result in a fire.
- Gasoline powered equipment or fuel containers should not be stored in basement or any enclosed



area where heating appliances or open pilot lights are present.

- Maximum raking/slicing results and safety can only be expected if the unit is maintained and operated correctly.

- **FAILURE TO FOLLOW ALL CAUTIOUS OPERATING PRACTICES CAN RESULT IN SERIOUS OPERATOR INJURY.**

OPERATING INSTRUCTIONS

- Do **NOT** use Power-Thatch in tall grass – mow first.

- To avoid damage to turf do **NOT** use Power-Thatch on water soaked lawns.

- To avoid damage to turf do **NOT allow the raking/slicing shaft to rotate continuously while forward motion is stopped.**

- Never run an engine inside a closed area.

- To reduce fire hazard, keep power-thatch free of grass, leaves, or other debris build-up. Clean up oil or fuel spillage. Allow power-thatch to cool at least 5 minutes before storing.

- Before cleaning, repairing, or inspecting, make certain the blade and all moving parts have stopped. Disconnect the spark plug wire, and keep the wire away from the spark plug to prevent accidental starting.

- Check the blade and engine mounting bolts at frequent intervals for proper tightness. Also, visually inspect blade for damage (e.g., bent, cracked or worn). Replace with blade which meets original equipment specifications listed in this manual.

- Keep all nuts, bolts, and screws tight to be sure the equipment is in safe working condition.

- Never tamper with safety devices. Check their proper operation regularly.

- After striking a foreign object, stop the engine, remove the wire from the spark plug, and thoroughly inspect the power-thatch for any damage. Repair the damage before starting and operating the power-thatch.

- Never attempt to make a wheel or cutting adjustment while the engine is running.
- Do not change the engine governor setting or over speed the engine. Excessive engine speeds are dangerous.

SLOPE OPERATION

- If the slope is greater than 15 degrees as shown on the slope gauge, do not operate this power-thatch on that area or serious injury could result.
- Comb across the face of slopes, never up and down. Exercise extreme caution when changing direction on slopes. Watch for holes, ruts, hidden objects, or bumps. Tall grass can hide obstacles. Always be sure of your footing. A slip and fall can cause serious personal injury.

SECTION 1: IMPORTANT SAFE OPERATION PRACTICES

⚠ WARNING: THIS SYMBOL POINTS OUT IMPORTANT SAFETY INSTRUCTIONS WHICH, IF NOT FOLLOWED, COULD ENDANGER THE PERSONAL SAFETY AND/OR PROPERTY OF YOURSELF AND OTHERS. READ AND FOLLOW ALL INSTRUCTIONS IN THIS MANUAL BEFORE ATTEMPTING TO OPERATE YOUR LAWN POWER-THATCH. FAILURE TO COMPLY WITH THESE INSTRUCTIONS MAY RESULT IN PERSONAL INJURY. WHEN YOU SEE THIS SYMBOL, HEED ITS WARNING.

⚠ DANGER: Your power-thatch was built to be operated according to the rules for safe operation in this manual. As with any type of power equipment, carelessness or error on the part of the operator can result in serious injury. This lawn power-thatch is capable of amputating hands and feet and throwing objects. Failure to observe the following safety instructions could result in serious injury or death.

SECTION 2: LOCATE MODEL AND SERIAL NUMBER

Serial Tag shows this power-thatch's model and serial number on the chassis of the power-thatch.

SECTION 3: SAFTY SPECIFICATIONS

- Regard the power-thatch as potentially dangerous lawn and turf power equipment.
- Know and understand the unit prior to starting engine.



-
- Do not allow children or young teenagers to operate unit and instruct children to keep away from the area of operation always.
 - Do not operate unit when barefoot or without proper footwear. Also, do not operate in wet grass as it will result in poor footing.
 - Do not operate unit after dark unless there is sufficient artificial lighting. Do not fill unit with gasoline indoors, while smoking or while engine is hot or running. Avoid spilling gasoline on unit to prevent fires. Prior to starting, clear entire area of debris that could be propelled the slicing shaft during operation.

SECTION 4: ASSEMBLY INSTRUCTIONS

FIRST

Remove unit from shipping carton.

SECOND

Unfold upper handle and secure by tightening the two for-prong knobs.

THIRD

Service engine as per engine manual.

SECTION 5: FINAL ADJUSTMENTS

FIRST

Before operating, make sure the belt is between the two belt guides. These belt guides are located behind the belt guard. In the engaged position, adjust the guides to allow 1/8" clearance between guide and belt.

SECOND

Adjust engagement lever tension for best hand comfort by moving the lower cable mounting via the slot. (Move mounting forward for less tension and backward for more tension.)

NOTE: Proper belt tension (1/4" deflection with 10lbs. or force) is necessary to turn the shaft while working.

THIRD

Before starting, height adjustment should be in the highest position. This also applies when crossing sidewalks and curbing.

ASSEMBLY

Follow steps 1 through 3 to assemble your power-thatch.

Step 1: Lift upper handle.

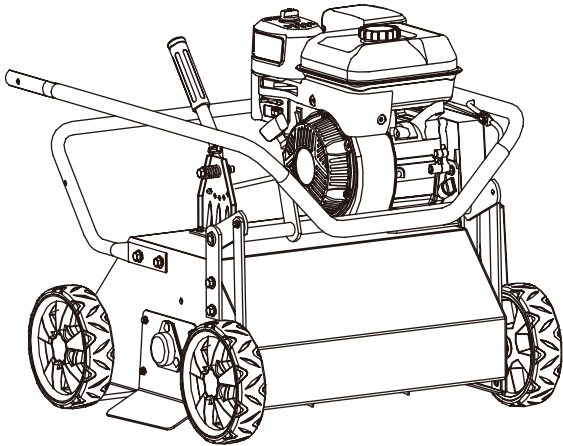

Step 2: Align upper handle with lower handle.

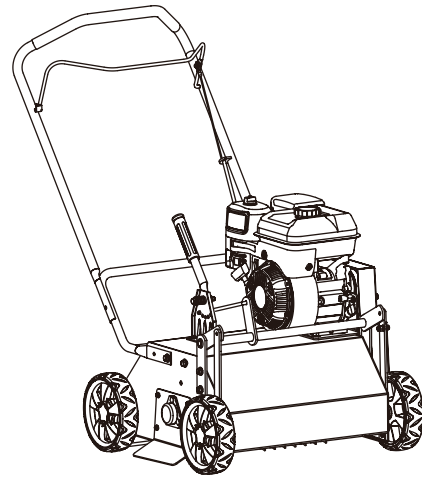

Step 3: Put nut into the slots of knob nut, using bolt fix upper and lower handle.

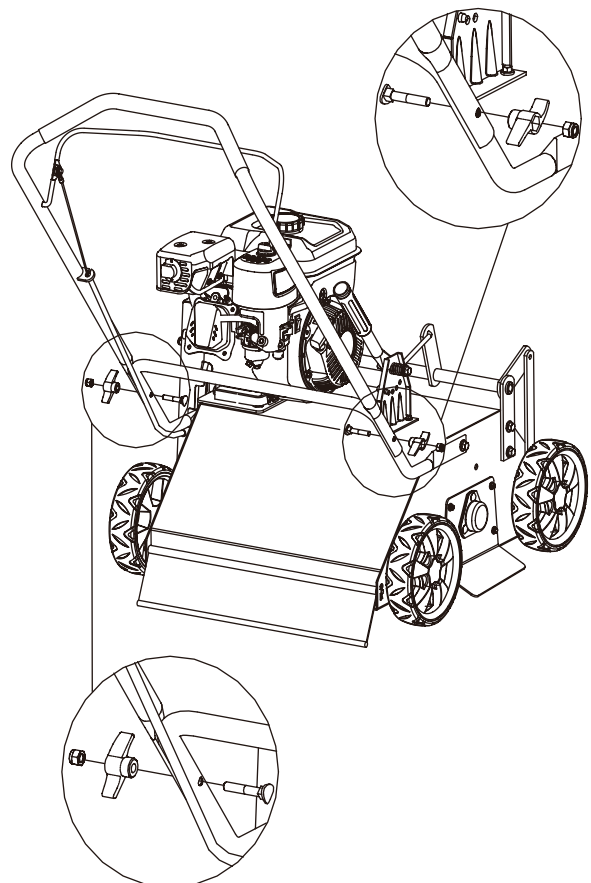



SECTION 6: CONTROLS AND OPERATING

⚠ WARNING: Keep hands and feet away from the chute area on the cutting deck.

The operation of any power-thatch can result in foreign objects being thrown into the eyes, which can result in severe eye damage. Always wear safety glasses or eye shields.

NOTE: For best results raise the cutting position until it is determined which height is best for your lawn. See CUTTING HEIGHT ADJUSTMENT LEVER in the CONTROLS section.

GASOLINE AND OIL FILL-UP

Service the engine with gasoline and oil as instructed in the separate engine manual. Read all instructions carefully.

⚠ WARNING: Never fill fuel tank indoors with engine running or until the engine has been allowed to cool for at least two minutes after running.

NOTE: If any problems are encountered, refer to the TROUBLE SHOOTING GUIDE Section of this manual.

⚠ WARNING: The blade continues to rotate for a few seconds after the engine is shut off.

BAIL STYLE HANDLE DRIVE

(See FIG 5)

This handle is on the top of upper handle. If you want to work, Squeeze this bail against the handle. If you want to stop, release it.

⚠ WARNING: Bail style drive is a safety device. Never attempt to bypass its operations.

CUTTING HEIGHT ADJUSTMENT LEVER

(See FIG. 5)

The cutting height adjustment lever is located on the right of engine. To adjust the cutting height, hold the adjustment handle, pull to the right, make the rod out of the

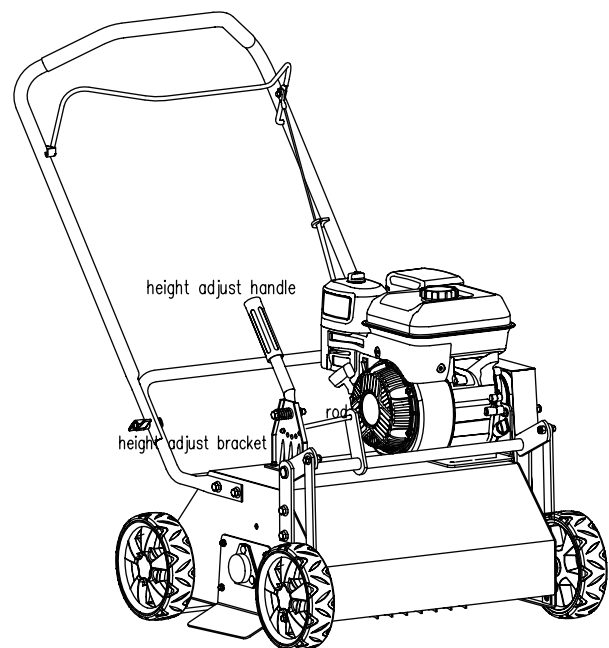

FIG. 5

height adjustment bracket, move it forward or backward to choose suitable height.
See FIG. 7

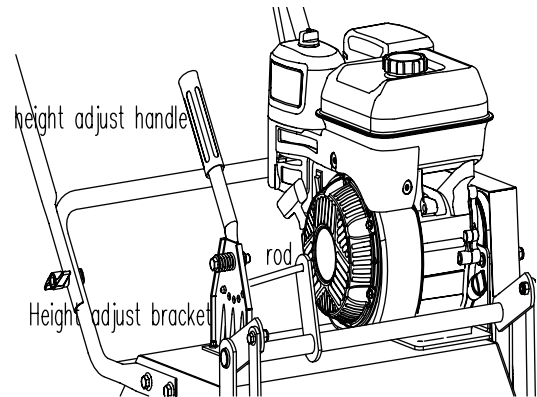

FIG.7

SECTION 7: MAINTENANCE

⚠ WARNING: Always stop engine and disconnect spark plug wire before cleaning, lubricating or doing any kind of service work on the power-thatch.

NOTE: When tipping the power-thatch, empty the fuel tank. Never tip the power-thatch more than 90 degrees in any directions and do not leave the power-thatch tipped for any length of time. Oil can drain into the upper part of the engine causing a starting problem.

ENGINE

Refer to the separate engine manual for all engine maintenance instructions.

- Maintain engine oil as instructed in the separate engine manual packed with your power-thatch. Read and follow instructions carefully.
- Service air cleaner every 25 hours under normal conditions. Clean every few hours under extremely dusty conditions. Poor engine performance and flooding usually indicate that the air cleaner should be serviced. To service the air cleaner, refer to the separate engine manual packed with your power-thatch.
- The spark plug should be cleaned and the gap reset once a season. Spark plug replacement is recommended at the start of each mowing season; refer to engine manual for correct plug type and gap specifications.
- Clean the engine regularly with a cloth or brush. Keep the cooling system (blower housing area)

clean to permit proper air circulation which is essential to engine performance and life. Be certain to remove all grass, dirt and combustible debris from muffler area.

BLADE SHAFT

The inside blade shaft should be cleaned after each use. If not, it will cause rust and corrosion, and increase the engine 's burden. After pulling out spark plug, can use wood chip, or other tool to clean fixtures.

BLADE REMOVAL AND REPLACEMENT (See FIG 15)

- When removing the blade for replacement, protect your hands with a pair of heavy gloves or use a heavy rag to hold the blade.
- Remove the pin which is holding the blade.

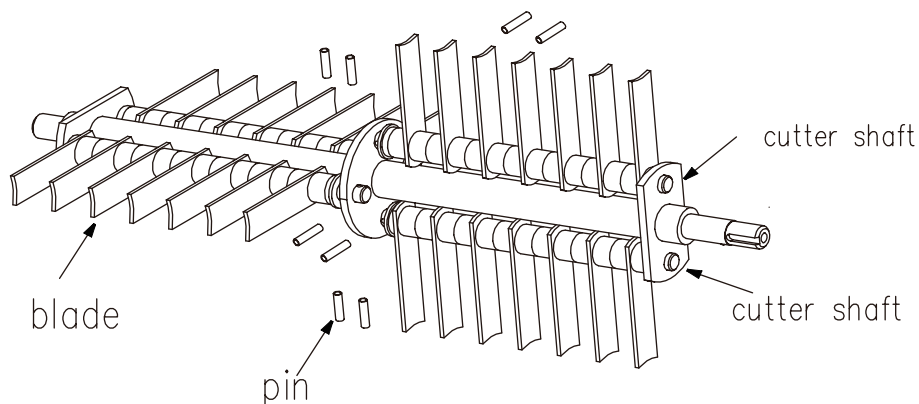

FIG.15

⚠ WARNING: Periodically inspect the blade adapter for cracks, especially if you strike a foreign object. Replace when necessary.

DRIVE BELT REMOVAL AND REPLACEMENT (See FIG. 17)

- Disconnect the spark plug wire and ground it against the engine.
- Loosen the bolts and nuts.
- Remove the belt cover.
- Remove the old belt.
- Replace with a new V-belt, route V-belt around pulleys.

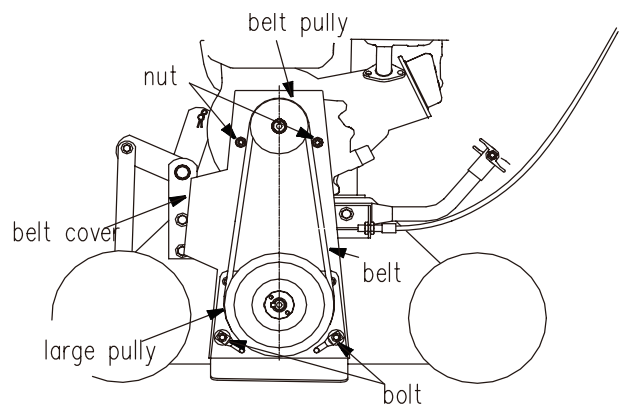

FIG.17

LUBRICATION

⚠ WARNING: Always stop engine and disconnect spark plug wire before cleaning, lubricating or doing any kind of service work on the power-thatch.

- Lubricate the wheels and bearings at least once a season with light oil (or engine oil). Also, if the wheels are removed for any reason, lubricate the surface of the rear axle or front shaft and the inner surface of the wheel with light oil.
- Follow engine manual for lubrication instructions.

SECTION 8: OFF-SEASON STORAGE

The following steps should be taken to prepare your power-thatch for storage.

- Clean and lubricate power-thatch thoroughly as described in the lubrication instructions.
- Refer to engine manual for correct engine storage instructions.
- Coat power-thatch's blade with chassis grease to prevent rusting.
- Store power-thatch in a dry, clean area. Do not store next to corrosive materials, such as fertilizer.

NOTE: When storing any type of power equipment in a poorly ventilated or metal storage shed, care should be taken to rust-proof the equipment. Using a light oil silicone, coat the equipment, especially cables and all moving parts.



SECTION 9: TROUBLE SHOOTING GUIDE

Trouble	Cause	Remedy
Engine fails to start	Blade control handle disengaged. Spark plug wire disconnected. Throttle control lever not in correct starting position. Fuel tank empty, or stale fuel. Blocked fuel line. Faulty spark plug. Engine flooded.	Engage blade control handle. Connect wire to spark plug. Move throttle lever to FAST or START position. Fill tank with clean, fresh gasoline. Clean fuel line. Clean, adjust gap or replace. Crank engine with throttle in FAST position.
Engine runs erratic	Power-thatch running in START position. Spark plug wire loose. Blocked fuel line or stale fuel. Vent in gas cap plugged. Water or dirt in fuel system. Dirty air cleaner. Carburetor out of adjustment.	Move throttle lever to FAST position. Connect and tighten spark plug wire. Clean fuel line, fill tank with clean, fresh gasoline. Clean vent. Drain fuel tank. Refill with fresh fuel. Clean air cleaner. Adjust carburetor.
Engine overheats	Engine oil level low. Air flow restricted. Carburetor not adjusted properly.	Fill crankcase with proper oil. Remove blower housing and clean. Adjust carburetor.
Occasional skip(hesitates) at high speed	Spark plug gap too close.	Adjust gap to .030".
Idles poorly	Spark plug fouled, faulty or gap too wide. Carburetor improperly adjusted. Dirty air cleaner.	Reset gap to .030" or replace spark plug. Adjust carburetor. Clean air cleaner.
Uneven cut	Wheels not positioned correctly. Dull blade.	Place all four wheels in same height position. Sharpen or replace blade.

NOTE: For repairs beyond the adjustments listed above, contact your nearest authorized service dealer.

SECTION 10: TECHNICAL DATA

Model	RSA20N-BS50
Dimensions (inch)	51.18×26.77×39.37
N.W/G. W (lb.)	90/101
Working width (inch)	20
Height adjustment (inch)	0-1.0 (5 positions)
Transmission type	Belt

FINAL ASSEMBLY

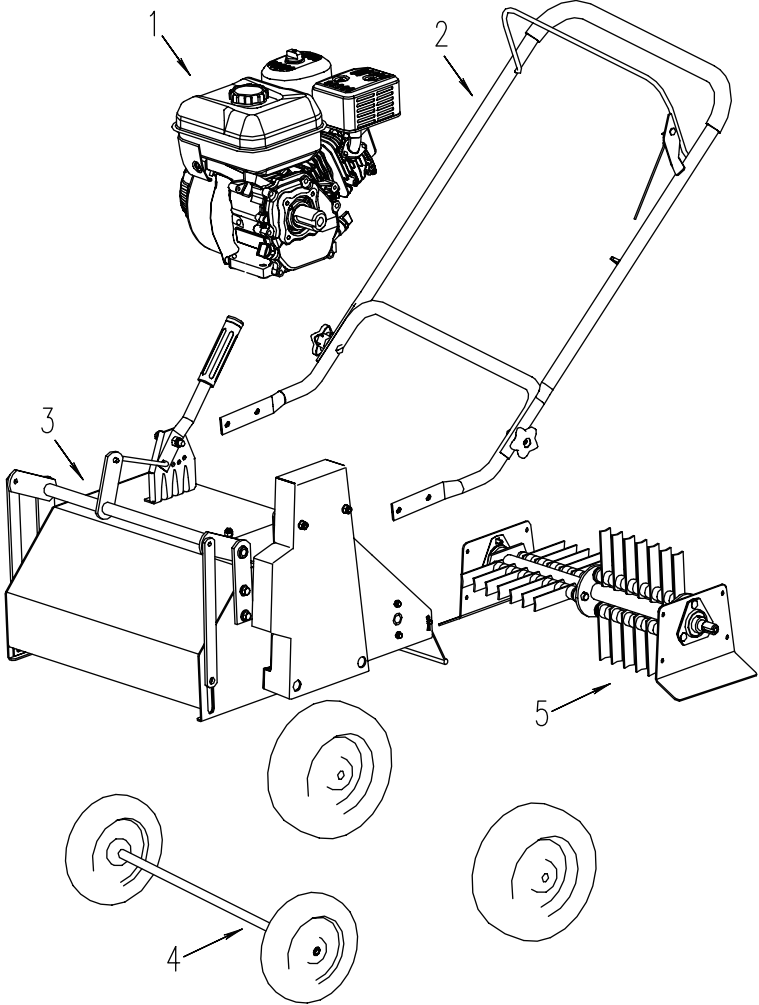

REF. NO.	PART NO.	DESCRIPTION	QTY
1	750SERIES	B&S ENGINE	1
2		HANDLEBAR & CONSOLE	1
3		HOUSING ASSEMBLY	1
4		DRIVE ASSEMBLY	1
5		BLADE ASSEMBLY	1

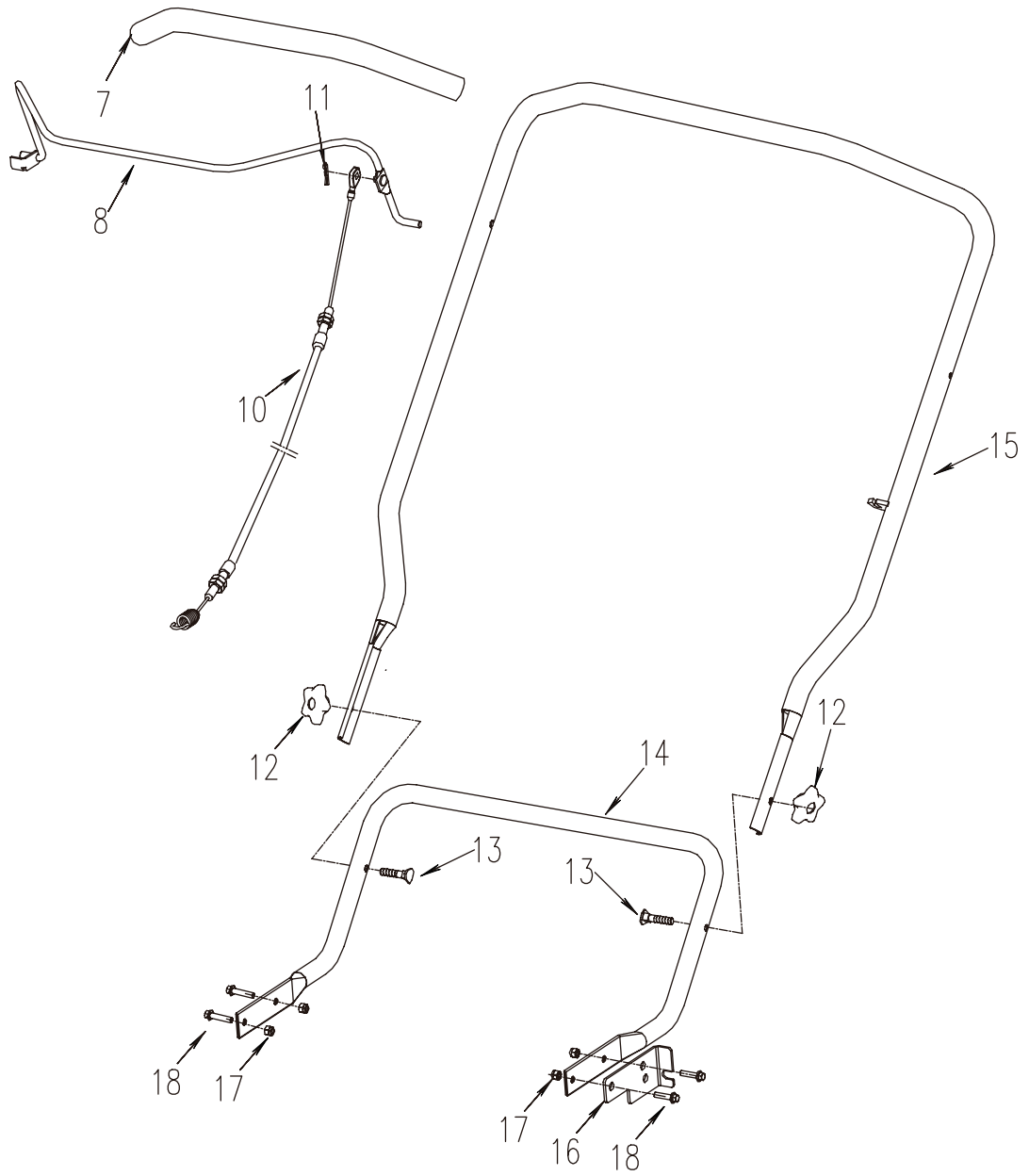

HANDLEBAR & CONSOLE



REF. NO.	PART NO.	DESCRIPTION	QTY
7	R204002	Handle Grip	1
8	R200213	Drive Clutch Lever	1
10	R204020	Cable Unit	1
11	16-6	Lock catch 6	1
12	XSZ56-1-09	Knob	2
13	1810061	Bolt	2
14	R204003	Lower Handle	1
15	R200211	Upper Handle	1
16	R200207	Cable fixed plate	1
17	B6182-10	Nut M10	4
18	B5787-1025	Bolt M10*25	4

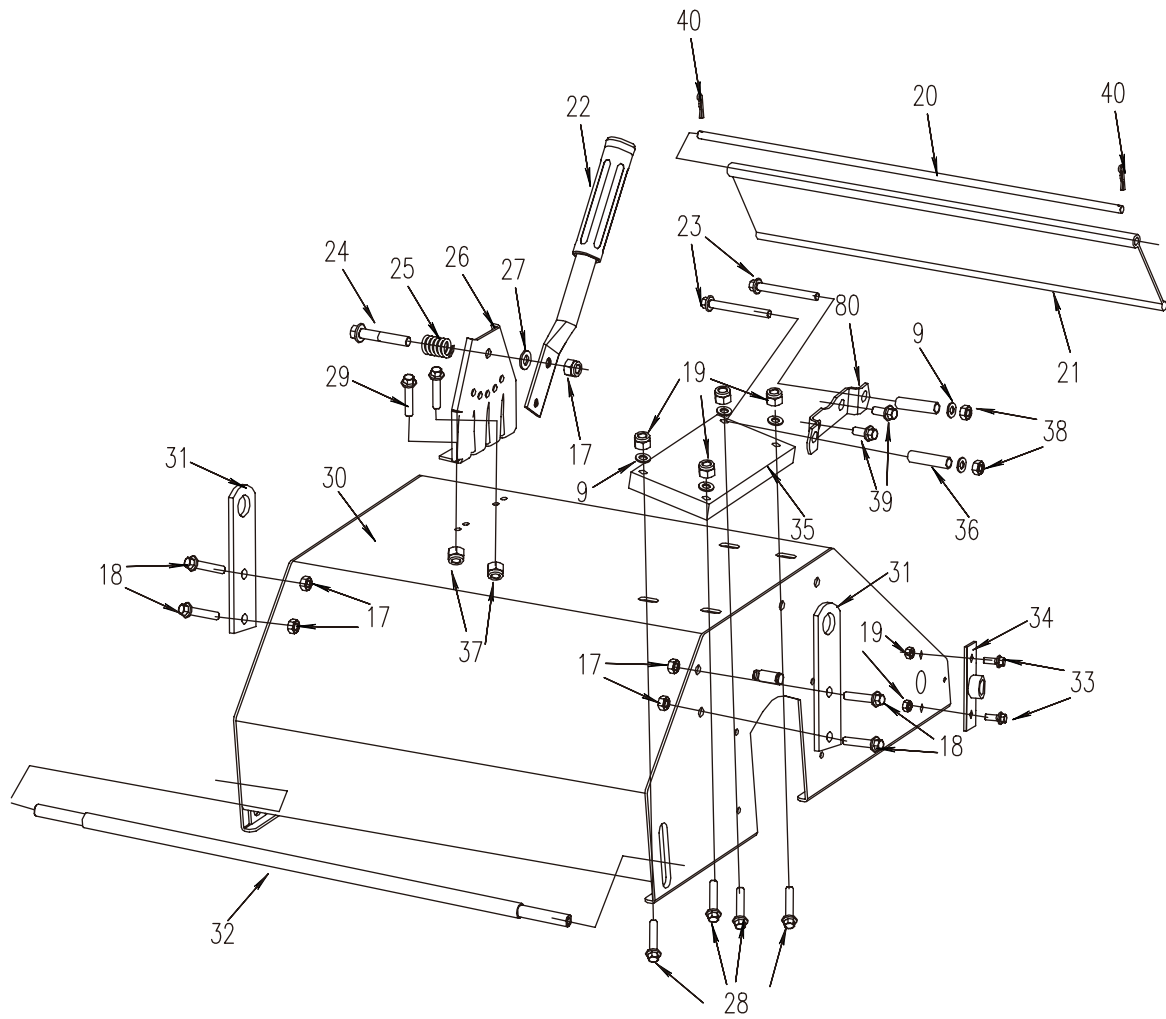

HOUSING ASSEMBLY



REF. NO.	PART NO.	DESCRIPTION	QTY
9	B97.1-8	Washer 8	6
17	B6182-10	Nut M10	5
18	B5787-1025	Bolt M10*25	4
19	B6182-8	Nut M8	10
20	R200007	Rod, Rear Guard	1
21	R200008	Rear Guard	1
22	R200040	Adjustment Lever ASM	1
23	B5782-875	Bolt M8*75	2
24	B5787-1060	Bolt M10*60	1
25	R200006	Pressure spring	1
26	R200206	Height Adjustment	1
27	B97.1-10	Washer 10	1
28	B5787-855	Bolt M8*55	4
29	B5787-616	Bolt M6*16	2
30	R200201	Housing	1
31	R200015	Fixed plate	2
32	R200013	Front Axel	1
33	B5787-820	Bolt M8*20	4
34	R201020	Reinforcing plate	2
35	R200205	Fixed plate	1
36	R200061	Bushing	2
37	B6182-6	Nut M6	2
38	B6170-8	Nut M8	2
39	2200020	JH Engine Bolt	2
40	XSZ56-1-17	Hair Pin	2
80	R200209	Ledger plate	1

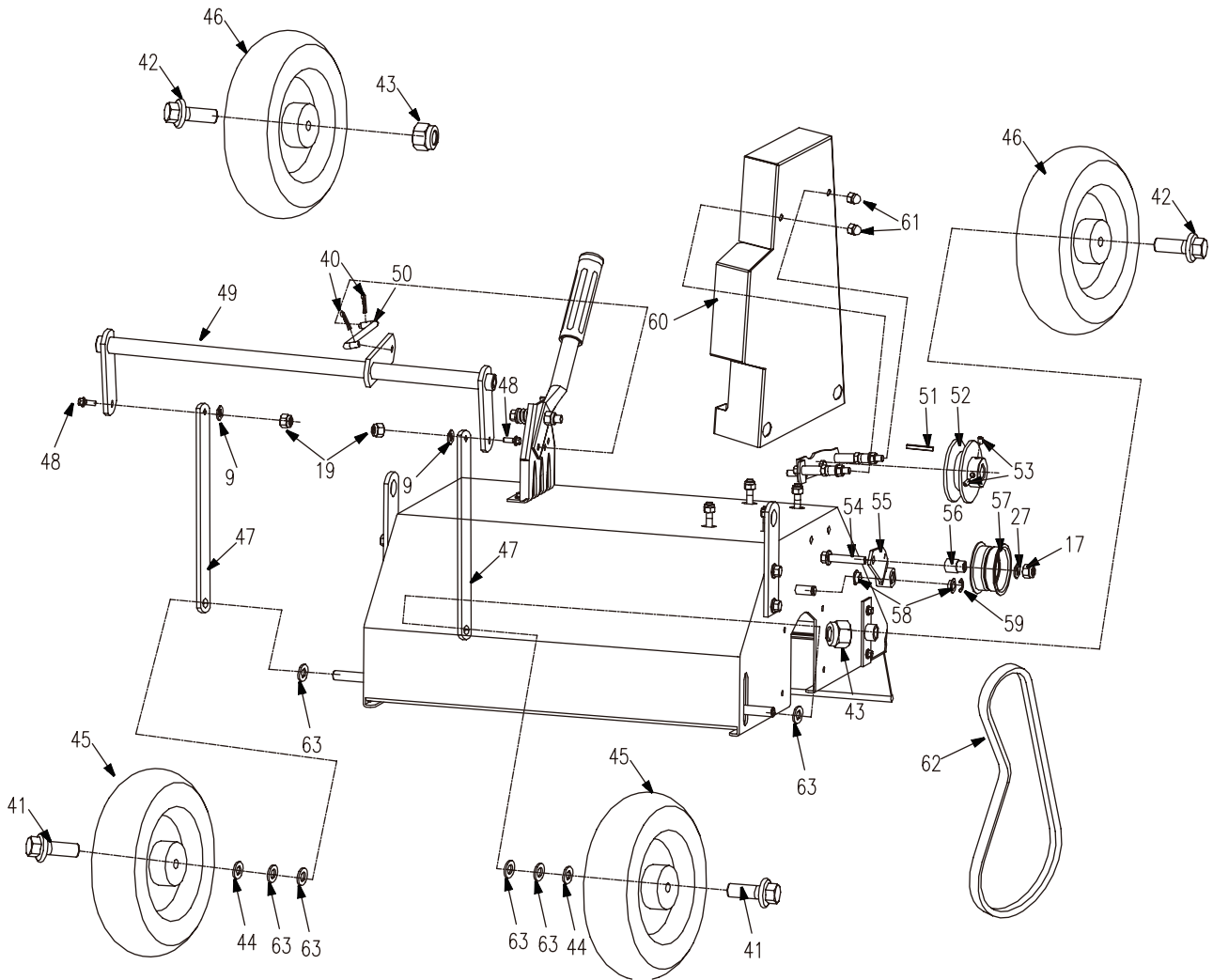

DRIVE ASSEMBLY



REF. NO.	PART NO.	DESCRIPTION	QTY
9	B97.1-8	Washer 8	2
17	B6182-10	Nut M10	1
19	B6182-8	Nut M8	2
27	B97.1-10	Washer 10	1
40	XSZ56-1-17	Hair Pin	2
41	B5787-1020	Bolt M10*20	2
42	B5787-16110	Bolt M16*110	2
43	B6182-16	Nut M16	2
44	B955-16	Washer 16	2
45	R200080	Front Wheel	2
46	R200090	Rear Wheel	2
47	R200001	Adjusting Plate	2
48	B5787-825	Bolt M8*25	2
49	R200030	Adjustment link rod WLD	1
50	R200012	Connecting rod	1
51	XSS46-02	Key	1
52	R200003	Pulley	1
53	B78-610	Screw M6*10	2
54	B5787-1050	Bolt M10*50	1
55	R200071	Swing arm	1
56	R200077	Bronze Bushing	1
57	R200075	Tension wheel	1
58	R200076	Flange bearing	2
59	B896-9	E-Clip 9	1
60	R200019	Pulley cover	1
61	B923-8	Cap Nut M8	2
62	R200004	Belt Bando SB-37	1
63	B97.1-16	Washer 16	6

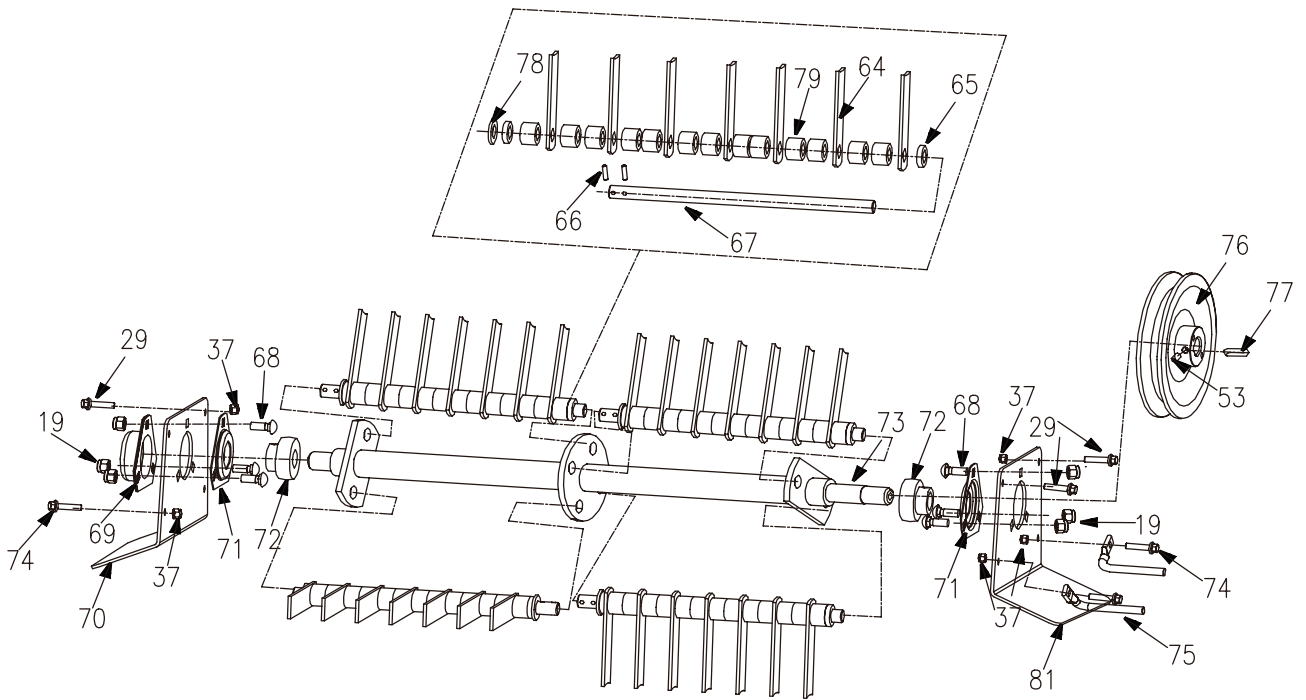

FLAIL BLADE ASSEMBLY



REF. NO.	PART NO.	DESCRIPTION	QTY
19	B6182-8	Nut M8	6
29	B5787-616	Bolt M6*16	4
37	B6182-6	Nut M6	8
53	B78-610	Screw M6*10	2
64	R202001	Flail Blade	28
65	R202005	Bushing	8
66	B879.1-418	Flexible pin 4*16	8
67	R202003	Blade shaft	4
68	B801-820	Bolt M8*20	6
69	R202007	Bearing cap	1
70	R202006A	Guard plate-RH	1
71	R202009	Internal bearing cap	2
72	SBPFT204	Mounted Bearings	2
73	R202010	Main shaft	1
74	B5787-620	Bolt M6*20	4
75	R200010	Guard rod	2
76	R200009	Pulley	1
77	B1096-625C	Key C6*25	1
78	B97.1-14	Washer 14	4
79	R202004	Bushing	52
81	R202008A	Guard plate-LH	1



ENCORE EQUIPMENT
401 N. Commerce Street ,
Beatrice ,NEBRASKA 68310
TEL: 402-228-4255
FAX: 402-223-4103
[www. Encoreequipment.com](http://www.Encoreequipment.com)