



61B27LDML

**PARTS
MANUAL**



Table of Contents

General Information	
Encore Warranty Information	4
61B27LDML Quick Reference Sheet.....	5
Deck Components	
Hand Lift	6
Foot Lift.....	8
Mainframe Components	10
Seatframe Components	12
Hydraulics Components.....	14
Electrical Components.....	16
Wire Harness.....	18
Engine Wire Harness.....	19
Decal List	20
Notes	22



WARNING:

THE ENGINE EXHAUST FROM THIS PRODUCT CONTAINS CHEMICALS KNOWN IN THE STATE OF CALIFORNIA TO CAUSE CANCER, BIRTH DEFECTS OR OTHER REPRODUCTIVE HARMS.

IMPORTANT:

A separate Engine Owner's Manual is included with your owner's packet which contains additional engine information that will not be repeated in this manual. You are urged to read it before attempting any operation or repair of the engine. Engine Owner's Manual covers the engine manufactures warranty.

ENCORE WARRANTY

WHAT IS COVERED BY THIS WARRANTY

This warranty extends to the original retail purchaser only and commences on the date of original retail purchase of All Encore "Premier", "X-treme", and "Prowler" Series:

1. Residential use: The warranty will be **Two years from the date of purchase and 90 days for rental use** against defects in workmanship and materials for any Encore rider that is used for consumer purpose. Normal residential use means use of product on owners' property only.
2. Commercial use: The warranty will be **Two year from the date of purchase and 90 days for rental use** against defects in workmanship and materials for any Encore rider that is used for commercial purpose.
3. If the Purchaser discovers within this warranty period a defect in materials or workmanship:
 - Purchaser must promptly notify an Authorized Encore Dealer and return the mower, including any defective parts, to an Authorized Encore Service Dealer.
 - Encore Mfg. Co. Inc. will determine if material or workmanship is defective and then either repair or replace such parts.
 - Service calls and/or transportation expense of the product to and from the authorized dealer, for warranty work, will be paid by the owner of the product.
4. Encore Mfg. Co., Inc. provides a limited warranty for **90 days from the date of purchase** against defects in workmanship and materials for all parts, excluding **over the counter electrical parts and blades**.
5. The Deck Shell warranty is **Ten years from the date of purchase** against defects in workmanship and materials for any Encore rider that is used for consumer and commercial use only.
6. **NOTICE:** Cutter housings, electrical components, hydraulic components and electric-clutch must be returned before warranty will be paid.
7. **The engine warranty is covered by its respective manufacturer.** Please refer to the manufacture's warranty statement in the manufacture's engine manual that is included in the literature packet. **Engine warranties should be referred to the nearest authorized service outlet of the engine manufacturer.**

Encore Mfg. Co., Inc. reserves the right to change or improve the design of any mower without assuming any obligation to modify any mower previously manufactured.

WHO MUST PERFORM THE WARRANTY SERVICE

All warranty service will be performed by dealers authorized by Encore Mfg., Co., Inc. Service calls and/or transportation expense of the product to and from the authorized dealer, for warranty work, will be paid by the owner of the product. For warranty service you can contact an authorized dealer or contact:

Encore Mfg., Co., Inc.
PO Box 888
Beatrice, Nebraska 68310
1-800-267-4255
www.seriousred.com

WHAT IS NOT COVERED BY THIS WARRANTY

Encore Mfg., Co., Inc. does not warranty:

- Repairs made by unauthorized persons.
- Damage caused by use of the Encore equipment for purposes other than those for which it was designed

- Damages caused by disasters such as fire, flood, wind, and lightning.
- Damages caused by neglect, abuse, abnormal use, improper or unreasonable use, accident, negligence or misuse.
- Repairs or replacement resulting from the use of unauthorized parts, accessories or attachments.
- Repairs or replacement as the result of any alterations or modifications, in the determination of Encore, which adversely affects the operation, performance or durability of the equipment.
- Encore unit which has the serial number removed or made illegible.
- Depreciation or damage caused by normal wear, lack of reasonable and proper maintenance or failure to follow the product's owner's manual provided by Encore Mfg. Co., Inc.
- Normal maintenance parts and service including, but not limited to: filters, fuel, lubricants, tune-up parts, belts, blades, blade sharpening, brake or steering adjustments.
- Repairs necessary due to improper fuel, contaminates in the fuel system, or failure to properly prepare the fuel system prior to any period of non-use over three months.

LIMITATION OF REMEDIES

In no case shall Encore Mfg., Co., Inc., be liable for any special, incidental, or consequential damages based upon breach of warranty, breach of contract, negligence, strict liability in tort, or any other legal theory.

Such damages include, but are not limited to

- Loss of profits
- Loss of savings or revenue
- Loss of use of Encore mower or any associated equipment
- Cost of capital
- Cost of any substitute equipment, facilities, services, or downtime
- The claims of third parties including customers, and injury to property
- Some states do not allow the exclusion or limitation of incidental or consequential damages, so the above limitation or exclusion may not apply to you.

OWNER'S RESPONSIBILITY

You must maintain your Encore Product following the maintenance procedures described in your owner's manual. Such routine maintenance, whether performed by a dealer or by you, is at your expense.

This machine, like any other powered equipment, is potentially dangerous unless properly operated. Any operator must be cautious and keep safety in mind at all times. Any operator, prior to using the Encore equipment, should thoroughly familiarize himself with the owner's manual regarding operation and safety of the machine, as well as all safety warnings on the machine itself.

ENCORE MFG. CO., INC. CANNOT BE RESPONSIBLE FOR THE WAY YOU OPERATE, OR THE CONDITIONS IN WHICH YOU OPERATE THE MOWER. USE COMMON SENSE AT ALL TIMES.

WARRANTY REGISTRATION

1. The Warranty registration form **MUST** be completed and forwarded to Encore Mfg., Co., Inc., within fifteen days following date of purchase.
2. The date of purchase constitutes delivery.

Encore Mfg. Co., Inc. does not assume or authorize anyone to assume for them any other obligation.

General Information

Quick Reference Sheet

61B27LDML

Engine

26.5hp Briggs & Stratton Daihatsu diesel 582447-0219

Blades

823006 21" blade
823354 21" mulch blade

Belts

823242 blade drive belt
593219 pump drive belt
523374 clutch belt

Tires

583055 wheel/tire assy
583059 drive tire (24x12x12)
583058 rim w/ valvestem
N/A knobby tire assy
N/A knobby tire
583487 bar lug tire (23x10.5x12)
823220 front caster complete
823339 tire (13x6.5x6 front caster)
823338 front rim w/ valvestem

Spindles

583106 spindle assy comp.
583111 housing
363350 bearing
583112 shaft
583113 brg. Spacer tube

Transmission

593211 wheel motor TL0280US080AAWM **Seal Kit # 593217**
593210 hydro pump H1A14A4021DDAAA **Seal Kit # 593215**
593307 gearbox (model 200M)
423361 hydro filter

PTO shaft

593064 complete shaft
583481 yoke tube
593075 yoke shaft
523414 1" yoke
823372 3/4" yoke
523415 cross bearing
583271 1" power shaft (12.5")

Engine Base

Throttle

Choke

Muffler

Muffler Gasket

Clutch

Torque Specs

65 ft-lbs blade bolt

Pulleys

483025 tensioner pulley-clutc
823351 tensioner pulley-pump
523329 tensioner pulley-blade
523507 pump pulley
583107 pulley-blade spindle
523329 stationary idler pulley
593201 gearbox pulley
523507 pulley-power shaft
583200 pump drive pulley

Front Caster Bearings

363187 1" flange bearing

Brakes

583038 RH brake caliper
583039 LH brake caliper
583511 brake pad kit

Seat

583519 full suspension seat
583077 seat complete w/ trac
583089 seat cushion
583090 back cushion
593097 molded arm rest

Electrical Components

593051 wire harness
N/A safety module
583276 engine wire harness
583423 time delay module
523042 relay
423027 ignition switch
N/A starter relay
523034 park brake switch
593041 neutral switch
523031 PTO switch
523030 seat switch
523283 hour meter
823194 alarm

Deck Components

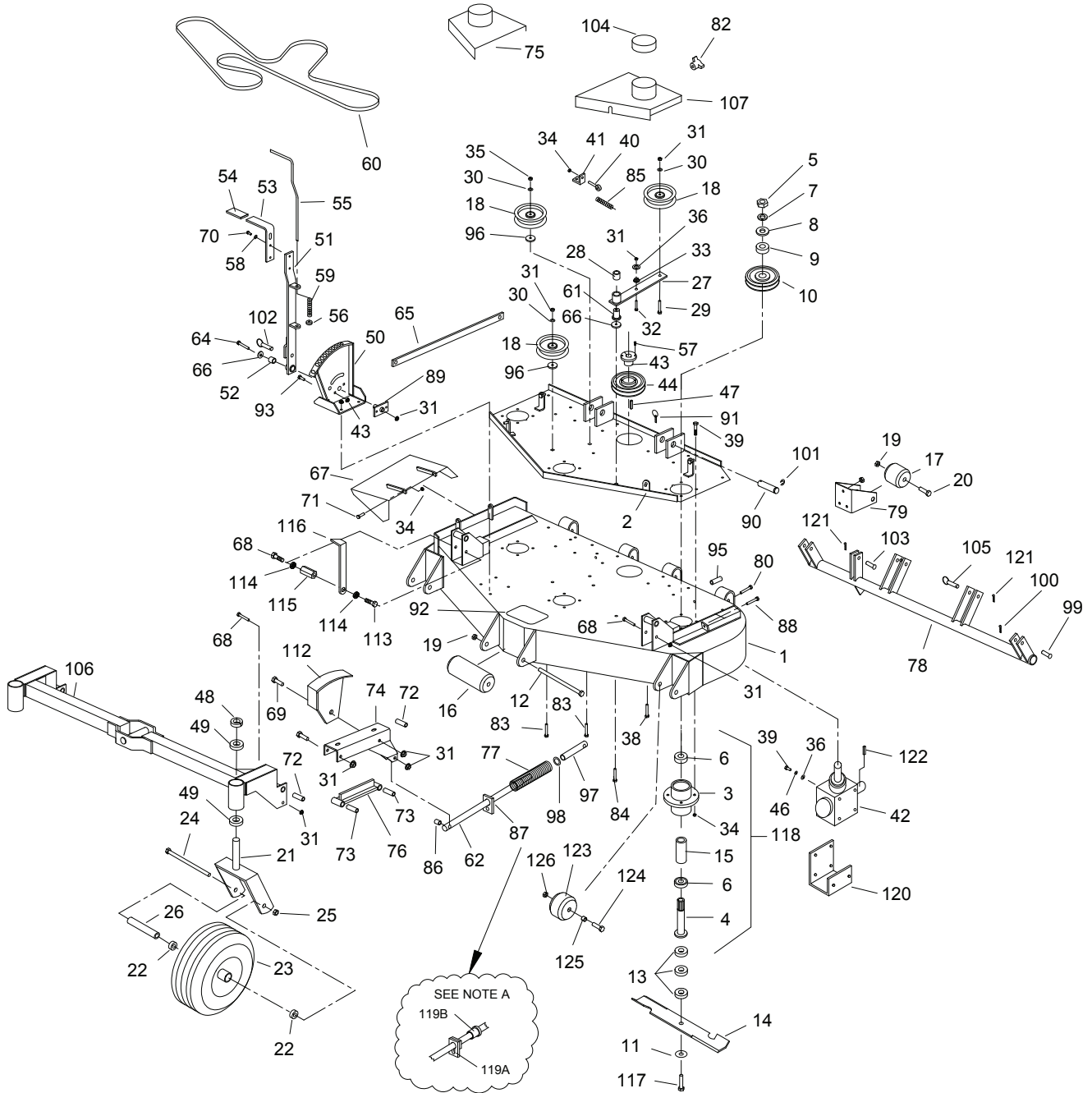

Deck Components

#	PART NO.	QTY	DESCRIPTION
1	582016	1	61" MC DECK WLDMNT
2	582012	1	61" MC DECK CHANNEL
3	583111	3	SPINDLE HOUSING
4	583112	3	SPINDLE SHAFT
5	104511	3	3/4"-16 HEX NUT
6	363350	6	BEARING - BLADE SPINDLE
7	105010	3	3/4" LOCK WASHER
8	105269	3	3/4" SAE FLAT WASHER
9	583110	3	PULLEY SPACER
10	583107	3	SPINDLE PULLEY - 5 3/4"
11	583108	3	5/8" SPRING DISC WASHER
12	100351	1	5/8"-11 X 8 1/2" HEX BOLT
13	583109	9	BLADE SPACER
14	823006	3	21.0" HI LIFT BLADE
15	583113	3	BEARING SPACER TUBE
16	603023	1	ANTI-SCALP ROLLER
17	523084	2	REAR DECK ROLLER
18	523329	3	FLTG. IDLER - FLAT
19	104261	3	5/8"-11 NYLOC NUT
20	100346	2	5/8"-11 X 4 1/2" HEX BOLT
21	822088	2	WIDE TAIL WHEEL STRUT
22	363187	4	1" BEARING
23	823220	2	WIDE TIRE ASSY (COMPLETE)
23A	823339	X	TIRE (13 X 6.5 X 6)
23B	823338	X	FRONT RIM W/ VALVESTEM
24	100352	2	5/8"-11 X 9" HEX BOLT
25	104261	2	5/8"-11 NYLOC NUT
26	823245	2	AXLE TUBE
27	822144	1	DECK IDLER ARM W/BUSHING
28	523111	1	3/4 PLASTIC BUSHING
29	107511	1	3/8"-16 X 2" CARRIAGE BOLT
30	105260	8	3/8" FLAT WASHER
31	104257	16	3/8"-16 NYLOC NUT
32	100275	1	5/16"-18 X 1 1/2" HEX BOLT
33	109001	2	5/16"-18 WHIZLOCK NUT
34	104256	36	5/16"-18 NYLOC NUT
35	109007	2	3/8"-16 WHIZLOCK NUT
36	105258	9	5/16" FLAT WASHER
37	107503	10	5/16"-18 X 3/4" CARRIAGE BOLT
38	107509	5	5/16"-18 X 1" CARRIAGE BOLT
39	100274	12	5/16"-18 X 1 1/4" HEX BOLT

Deck Components

#	PART NO.	QTY	DESCRIPTION
40	363080	1	RIGHT EYE BOLT
41	593126	1	SPRING MT.-DECK
42	593307	1	DECK - GEAR BOX
43	523371	1	3/4" TAPER HUB
44	523096	1	5" TAPERED PULLEY
46	105005	4	5/16" LOCK WASHER
47	107255	1	3/16" X 1" KEY
48	363145	2	1" CLAMP COLLAR
49	363187	2	1" FLANGE BEARING
50	582021	1	HEIGHT ADJUSTMENT BRACKET
51	592038	1	DECK HEIGHT BAR W/BUSHING
52	253059	1	ENGAGEMENT BUSHING
53	822062	1	DECK HEIGHT HANDLE W/GRIP
54	823312	1	GRIP
55	823149	1	HANDLE ROD
56	823093	1	3/8" CLAMP COLLAR
57	100252	6	1/4"-20 X 3/4" HEX BOLT
58	105004	2	1/4" LOCK WASHER
59	523028	1	ASSIST SPRING
60	823242	1	61" DECK BELT
61	423175	1	PUMP IDLER PIVOT
62	823155	2	CASTER ROD
64	100297	1	3/8"-16 X 2 1/4" HEX BOLT
65	582063	1	LIFT ARM WELDMENT
66	373089	1	3/8 STD RETAINING WASHER
67	582025	1	GRASS DEFLECTOR - 61
68	100300	4	3/8"-16 X 3" HEX BOLT
69	100301	4	3/8"-16 X 3 1/4" HEX BOLT
70	100251	2	1/4"-20 X 5/8" HEX BOLT
71	100273	2	5/16"-18 X 1" HEX BOLT
72	823330	4	CASTER ARM PIVOT
73	823090	4	CASTER BAR PIVOT
74A	582053	1	LEFT HAND CASTER ARM
74B	582051	1	RIGHT HAND CASTER ARM
75	582055	1	RIGHT HAND BELT SHIELD
76	582059	2	CASTER BAR WELDMENT
77	823150	2	HEAVY COMPRESSION SPRING
78	822124	1	61" DECK TUBE WELDMENT
79	583074	2	ROLLER MOUNT
80	100298	2	3/8"-16 X 2 1/2" HEX BOLT
82	753028	4	KNOB

Deck Components

#	PART NO.	QTY	DESCRIPTION
83	107516	2	3/8"-16 X 2 1/4" CARRIAGE BOLT
84	107513	3	3/8"-16 X 3" CARRIAGE BOLT
85	593074	1	SPRING - FLTG. IDLER
86	823153	2	CASTER ROD SPACER
87	592006	2	SPRING SLIDE (SEE NOTE A)
88	100030	2	3/8"-16 X 3" TAP BOLT
89	822132	1	DECK HEIGHT PIVOT
90	823333	2	DECK ATTACH PIN
91	108001	2	3/16" QUICK PIN
92	823200	1	STEP TREAD
93	107502	2	1/4"-20 X 3/4" CARRIAGE BOLT
94	104255	2	1/4"-20 NYLOC NUT
95	823314	2	TUBE SADDLE SPACER
96	483017	2	RIGHT HAND IDLER SPACER
97	823157	2	CASTER ROD END
98	109025	2	5/8" HEAVY WASHER
99	823210	2	1/2" X 2" CLEVIS PIN
100	106763	2	1/8" COTTER PIN
101	108510	4	7/8" E-RING
102	109026	1	1/2" X 2" DETENT PIN
103	823209	1	1/2" X 1 1/2" CLEVIS PIN
104	363161	2	BELT SHIELD CAP
105	823211	2	1/2" X 2 1/2" RING PIN
106	582010	1	FRONT AXLE
107	582057	1	LEFT HAND BELT SHIELD
112	582176	1	CUT GAGE WELDMENT
113	100291	1	3/8"-16 X 3/4" HEX BOLT
114	105006	2	3/8" LOCK WASHER
115	583422	1	NUT - CUT GAGE
116	583420	1	POINTER - CUT GAGE
117	100358	3	5/8"-11 X 2 1/4" HEX BOLT
118	583106	3	BLADE SPINDLE ASSY
119A	592006	1	SPRING RETAINER
119B	592097	1	LIFT SPRING BUSHING WITH ZERK
120	593096	1	GEAR BOX TRUSS
121	106778	2	3/16 X 1 1/2" COTTER PIN
122	107255	1	KEY - 3/16" X 1"
123	423023	2	ANTI-SCALP ROLLER
124	100336	2	1/2-13 X 4 1/2 HHCS
125	453132	2	SPACER
126	104259	2	1/2-13 NYLOC

Deck Components

#	PART NO.	QTY	DESCRIPTION
127	823309	1	FRAME SPACER - PLTD
128	533132	1	PLASTIC DISCHARGE CHUTE
129	593302	1	TOP CHUTE BRACKET
130	533136	1	BOTTOM CHUTE BRKT.
131	109007	4	3/8 - 16 WHIZLOCK NUT
132	107509	4	5/16-18 X 1 CARR. BOLT
133	105258	2	5/16 STD FLAT WASHER
134	104256	4	5/16-18 NYLOC NUT

NOTES:

- A PERFORMANCE UPGRADE FOR DECK SPRING ASSY. REQUIRES ITEM 119.
BOTH SIDES NEED BE UPGRADED AT THE SAME TIME.

Deck Components

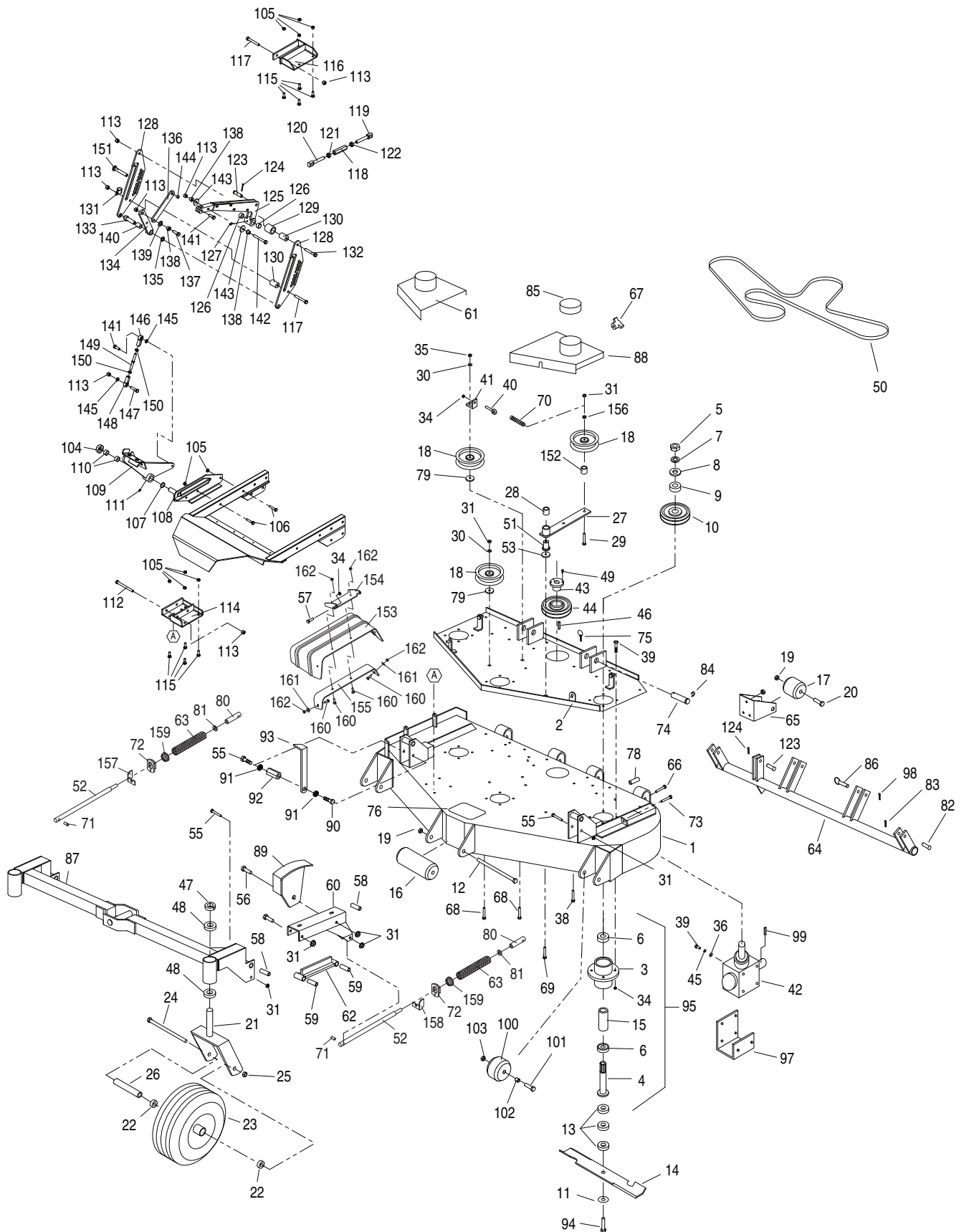

Deck Components

#	PART NO.	QTY	DESCRIPTION
1	582016	1	61" MC DECK WLDMNT
2	582012	1	61" MC DECK CHANNEL
3	583111	3	SPINDLE HOUSING
4	583112	3	SPINDLE SHAFT
5	104511	3	3/4"-16 HEX NUT
6	363350	6	BEARING - BLADE SPINDLE
7	105010	3	3/4" LOCK WASHER
8	105269	3	3/4" SAE FLAT WASHER
9	583110	3	PULLEY SPACER
10	583107	3	SPINDLE PULLEY - 5 3/4"
11	583108	3	5/8" SPRING DISC WASHER
12	100351	1	5/8"-11 X 8 1/2" HEX BOLT
13	583109	9	BLADE SPACER
14	823006	3	21.0" HI LIFT BLADE
15	583113	3	BEARING SPACER TUBE
16	603023	1	ANTI-SCALP ROLLER
17	523084	2	REAR DECK ROLLER
18	523329	3	FLTG. IDLER - FLAT
19	104261	3	5/8"-11 NYLOC NUT
20	100346	2	5/8"-11 X 4 1/2" HEX BOLT
21	822088	2	WIDE TAIL WHEEL STRUT
22	363187	4	1" BEARING
23	823220	2	WIDE TIRE ASSY (COMPLETE)
23A	823339	X	TIRE (13 X 6.5 X 6)
23B	823338	X	FRONT RIM W/ VALVESTEM
24	100352	2	5/8"-11 X 9" HEX BOLT
25	104261	2	5/8"-11 NYLOC NUT
26	823245	2	AXLE TUBE
27	822144	1	DECK IDLER ARM W/BUSHING
28	523111	1	3/4 PLASTIC BUSHING
29	107513	1	3/8"-16 X 3" CARRIAGE BOLT
30	105260	8	3/8" FLAT WASHER
31	104257	16	3/8"-16 NYLOC NUT
32	100275	1	5/16"-18 X 1 1/2" HEX BOLT
33	109001	2	5/16"-18 WHIZLOCK NUT
34	104256	36	5/16"-18 NYLOC NUT
35	109007	2	3/8"-16 WHIZLOCK NUT
36	105258	9	5/16" FLAT WASHER
37	107503	10	5/16"-18 X 3/4" CARRIAGE BOLT
38	107509	5	5/16"-18 X 1" CARRIAGE BOLT
39	100274	12	5/16"-18 X 1 1/4" HEX BOLT

Deck Components

#	PART NO.	QTY	DESCRIPTION
40	363080	1	RIGHT EYE BOLT
41	593126	1	SPRING MT.-DECK
42	593307	1	DECK - GEAR BOX
43	523371	1	3/4" TAPER HUB
44	523096	1	5" TAPERED PULLEY
45	105005	4	5/16" LOCK WASHER
46	107255	1	3/16" X 1" KEY
47	363145	2	1" CLAMP COLLAR
48	363187	2	1" FLANGE BEARING
49	100252	6	1/4"-20 X 3/4" HEX BOLT
50	823242	1	61" DECK BELT
51	423175	1	PUMP IDLER PIVOT
52	823155	2	CASTER ROD
53	373089	1	3/8 STD RETAINING WASHER
54	592143	1	GRASS DEFLECTOR - 61
55	100300	4	3/8"-16 X 3" HEX BOLT
56	100301	4	3/8"-16 X 3 1/4" HEX BOLT
57	100273	2	5/16"-18 X 1" HEX BOLT
58	823330	4	CASTER ARM PIVOT
59	823090	4	CASTER BAR PIVOT
60A	582053	1	LEFT HAND CASTER ARM
60B	582051	1	RIGHT HAND CASTER ARM
61	582055	1	RIGHT HAND BELT SHIELD
62	582059	2	CASTER BAR WELDMENT
63	593166	2	HEAVY COMPRESSION SPRING
64	822124	1	61" DECK TUBE WELDMENT
65	583074	2	ROLLER MOUNT
66	100298	2	3/8"-16 X 2 1/2" HEX BOLT
67	753028	4	KNOB
68	107516	2	3/8"-16 X 2 1/4" CARRIAGE BOLT
69	107513	3	3/8"-16 X 3" CARRIAGE BOLT
70	593074	1	SPRING - FLTG. IDLER
71	823153	2	CASTER ROD SPACER
72	592006	2	SPRING RETAINER WELDM'T
73	100030	2	3/8"-16 X 3" TAP BOLT
74	823333	2	DECK ATTACH PIN
75	108001	2	3/16" QUICK PIN
76	823200	1	STEP TREAD
77	104255	2	1/4"-20 NYLOC NUT
78	823314	2	TUBE SADDLE SPACER
79	483017	2	RIGHT HAND IDLER SPACER

Deck Components

#	PART NO.	QTY	DESCRIPTION
80	823157	2	CASTER ROD END
81	109025	2	5/8" HEAVY WASHER
82	823210	2	1/2" X 2" CLEVIS PIN
83	106763	2	1/8" COTTER PIN
84	108510	4	7/8" E-RING
85	363161	2	BELT SHIELD CAP
86	823211	2	1/2" X 2 1/2" RING PIN
87	582010	1	FRONT AXLE
88	582057	1	LEFT HAND BELT SHIELD
89	582176	1	CUT GAGE WELDMENT
90	100291	1	3/8"-16 X 3/4" HEX BOLT
91	105006	2	3/8" LOCK WASHER
92	583422	1	NUT - CUT GAGE
93	583420	1	POINTER - CUT GAGE
94	100358	3	5/8"-11 X 2 1/4" HEX BOLT
95	583106	3	BLADE SPINDLE ASSY
96	XXXXXX	X	XXXXXX
97	593096	1	GEAR BOX TRUSS
98	106778	2	3/16 X 1 1/2" COTTER PIN
99	107255	1	KEY - 3/16" X 1"
100	423023	2	ANTI-SCALP ROLLER
101	100336	2	1/2-13 X 4 1/2 HHCS
102	453132	2	SPACER
103	104259	2	1/2-13 NYLOC
104	523138	1	3/4 CLAMP COLLAR
105	104256	10	5/16-18 NYLOC NUT
106	100275	2	5/16-18 X 1-1/2 HHCS
107	593161	1	WAVEY WASHER - 3/4
108	592074	1	PEDAL MOUNT WELDMENT
109	592085	1	FOOT LIFT PEDAL W/ BUSHING
110	363089	2	BRONZE BUSHINGS
111	111004	1	1/4-28 ZERK
112	100303	1	3/8-16 X 4 HHCS
113	104257	7	3/8-16 NYLOC NUT
114	592080	1	FRONT HEIGHT MOUNT WELDM'T
115	107509	8	5/16-18 X 1 CARR. BOLT
116	592078	1	REAR LIFT MOUNT WELDMENT
117	100299	2	3/8-16 X 2-3/4 HHCS
118	593168	1	1/2 TURNBUCKLE
119	593170	1	1/2 RH ROD EYE
120	593172	1	1/2 LH ROD EYE

Deck Components

#	PART NO.	QTY	DESCRIPTION
121	109038	1	1/2-20 LH HEX JAM NUT
122	104755	1	1/2-20 HEX JAM NUT
123	593165	2	CLEVIS PIN - 1/2 X 1 1/2
124	106763	2	1/2 X 1 1/4 COTTER PIN
125	592117	1	LIFT ARM W/BUSHING
126	363089	2	BRONZE BUSHINGS
127	111004	1	1/4-28 ZERK
128	593138	2	CUTTING HEIGHT PLATE
129	593155	1	SPACER GRIP
130	593140	2	HEIGHT PLATE SPACER
131	603031	1	DRAIN CLAMP
132	100298	1	3/8-16 X 2-1/2 HHCS
133	593160	1	HEIGHT PLATE PIVOT
134	592082	1	LOWER SCISSOR ARM
135	363087	1	TRANSMISSION SHAFT SPACER
136	593146	1	UPPER SCISSOR ARM
137	100293	1	3/8-16 X 1-1/4 HHCS
138	123044	3	PIN BUSHING
139	593174	1	9/16 PLASTIC WASHER
140	253059	1	ENGAGEMENT BUSHING
141	100292	2	3/8-16 X 1 HHCS
142	100300	1	3/8-16 X 3 HHCS
143	753027	2	DISC SPRING WASHER
144	363174	1	EYE BOLT SPACER
145	105006	2	3/8 LOCK WASHER
146	593164	1	ROD END RHF 3/8
147	100294	1	3/8-16 X 1-1/2 HHCS
148	593163	1	ROD END 3/8
149	343158	1	FOOT PEDAL LINK
150	104754	2	3/8-24 HEX JAM NUT
151	109036	1	1/2 X 2 BALL LOCK PIN
152	823309	1	FRAME SPACER - PLTD
153	533132	1	PLASTIC DISCHARGE CHUTE
154	593302	1	TOP CHUTE BRACKET
155	533136	1	BOTTOM CHUTE BRKT.
156	109007	4	3/8 - 16 WHIZLOCK NUT
157	592090	1	CUP RETAINER - RIGHT
158	592092	1	CUP RETAINER - LEFT
159	592176	2	LIFT SPRING CUP

Deck Components

#	PART NO.	QTY	DESCRIPTION
160	107509	4	5/16-18 X 1 CARR. BOLT
161	105258	2	5/16 STD FLAT WASHER
162	104256	4	5/16-18 NYLOC NUT

NOTES:

Mainframe Components

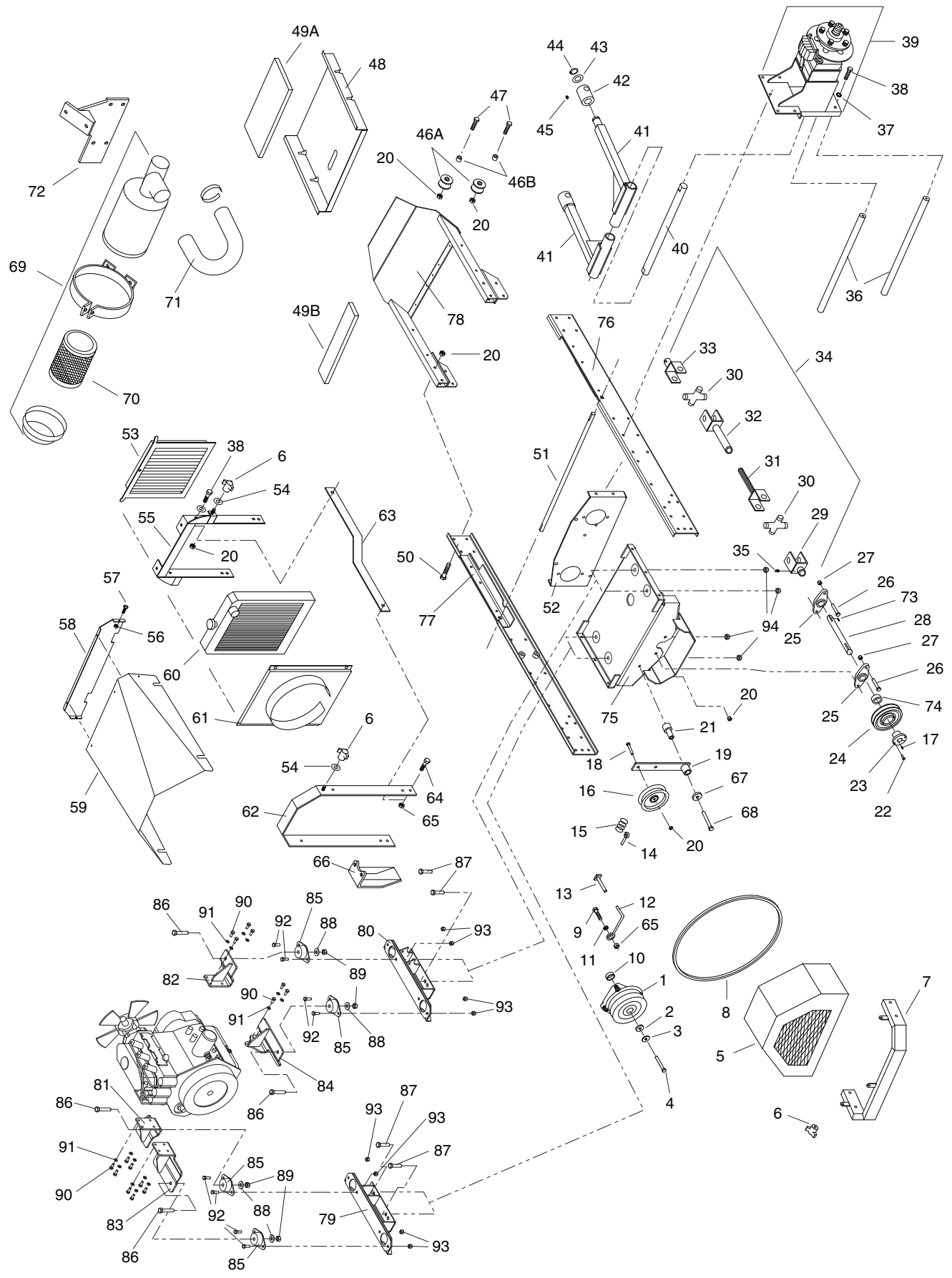

Mainframe Components

#	PART NO.	QTY	DESCRIPTION
1	583308	1	CLUTCH - 200 FT/LBS
2	373089	1	RETAINER WASHER
3	423069	2	7/16" SPRING DISC WASHER
4	100534	1	7/16"-20 X 1 1/4" HEX BOLT
5	582157	1	CLUTCH COVER - IL3
6	753028	7	KNOB
7	582132	1	ENGINE GUARD
8	523374	1	CLUTCH BELT
9	100273	16	5/16"-18 X 1" HEX BOLT
10	823248	2	CLUTCH SPACER 9/32
11	105258	6	5/16" FLAT WASHER
12	363075	1	ROUND BELT GUIDE
13	582169	1	CLUTCH STOP
14	363080	1	RIGHT EYE BOLT
15	593074	1	IDLER SPRING HH
16	483025	1	RIGHT HAND IDLER PULLEY
17	107259	1	1/4" X 1/4" X 1" KEY
18	100294	6	3/8"-16 X 1 1/2" HEX BOLT
19	422025	1	TENSIONER W/BUSHING
X	523111	X	BUSHING (SERVICE)
20	104257	32	3/8"-16 NYLOC NUT
21	823030	1	PUMP IDLER SUPPORT
22	100252	2	1/4"-20 X 3/4" HHCS
23	363215	1	TAPER LOCK HUB
24	523507	1	TAPER LOCK SHEAVE
25	823032	2	2-BOLT FLANGE BEARING
26	100311	4	7/16"-14 X 1 1/4" HEX BOLT
27	104258	4	7/16"-14 NYLOC NUT
28	583271	1	POWER SHAFT - MC - DSL
29	523414	1	1" YOKE
30	523415	2	CROSS & BEARING
31	593075	1	YOKE SHAFT
32	583481	1	YOKE TUBE
33	823372	1	3/4" YOKE
34	593064	1	DRIVE SHAFT MC
35	103295	2	3/8"-16 X 1/2" SET SCREW
36	823066	2	BRACE ROD - LOWER
37	105006	6	3/8" LOCK WASHER
38	100292	23	3/8"-16 X 1" HEX BOLT
39	XXXXXX	X	SEE HYDRAULIC ILLUSTRATION
40	823050	1	DECK ARM SHAFT

Mainframe Components

#	PART NO.	QTY	DESCRIPTION
41	822036	2	DECK ARM
42	822090	2	DECK SWIVEL W/ZERK
43	823015	4	DECK ARM WASHER
44	108502	2	SNAP RING
45	111004	12	1/4"-28 GREASE ZERK
46	583464	2	FRONT ROLLER - MC
46A	583464	2	FRONT ROLLER
46B	583490	2	FRONT ROLLER TUBE
47	100298	2	3/8"-16 X 2 1/2" HEX BOLT
48	593078	1	FOOT PLATE
49A	583374	1	FOOT REST PAD LARGE
49B	583373	1	FOOT REST PAD SMALL
50	100295	4	3/8"-16 X 1 3/4" HEX BOLT
51	823140	1	PARK SHAFT
52	XXXXXX	X	SEE HYDRAULIC ILLUSTRATION
53	583301	1	RADIATOR SCREEN
54	105260	13	3/8" FLAT WASHER
55	582159	1	RADIATOR MOUNT
56	104252	15	#10-24 NYLOC NUT
57	101039	17	#10-24 X 5/8" SCREW
58	583010	1	FRONT ENGINE COVER - IL3
59	583296	1	ENGINE COVER
60	SEE NOTE A	1	RADIATOR ASSY.
61	583476	1	FAN SHROUD
62	582161	1	HOOD BRACE
63	583356	2	HOOD SIDE BRACE
64	100271	4	5/16"-18 X 3/4" HEX BOLT
65	104256	5	5/16"-18 NYLOC NUT
66	582134	1	FUEL FILTER MOUNT
67	373089	1	RETAINING WASHER
68	100300	2	3/8"-16 X 3" HEX BOLT
69	583297	1	AIR CLEANER ASSY
70	583298	1	AIR FILTER ELEMENT
71	583369	1	AIR FILTER HOSE U-SHAPE
72	582153	1	AIR FILTER MOUNT
73	107258		POWER SHAFT KEY
74	363145	1	1" CLAMP COLLAR
75	582163	1	ENGINE BASE 31 GAS MC
76	582124	1	FRAME-RH-MC-3 CYL
77	582126	1	FRAME-RH-MC-3 CYL
78	582006	1	FRONT FRAME WLDMNT

Mainframe Components

#	PART NO.	QTY	DESCRIPTION
79	592122	1	LEFT ENGINE MT. CHANNEL
80	592124	1	RIGHT ENGINE MT. CHANNEL
81	592125	1	LEFT FRONT ENGINE MT
82	592128	1	RIGHT FRONT ENGINE MT
83	592130	1	LEFT REAR ENGINE MT
84	592132	1	RIGHT REAR ENGINE MT
85	593089	4	FLANGED ISO MOUNT
86	100331	4	1/2-13 X 2.5 HHCS
87	100329	4	1/2-13 X 2 HHCS
88	105264	4	1/2 STD Flatwasher
89	104259	8	1/2-13 NYLOCK NUT
90	109031	1	M8-1.25 X 20MM
91	105005	1	3/8 LOCK WASHER
92	100292	8	3/8-16 X 1 HHCS
93	104257	8	3/8-16 Nyloc Nut
94	104259	4	1/2-13 NYLOCK NUT

NOTES:

Seatframe Components

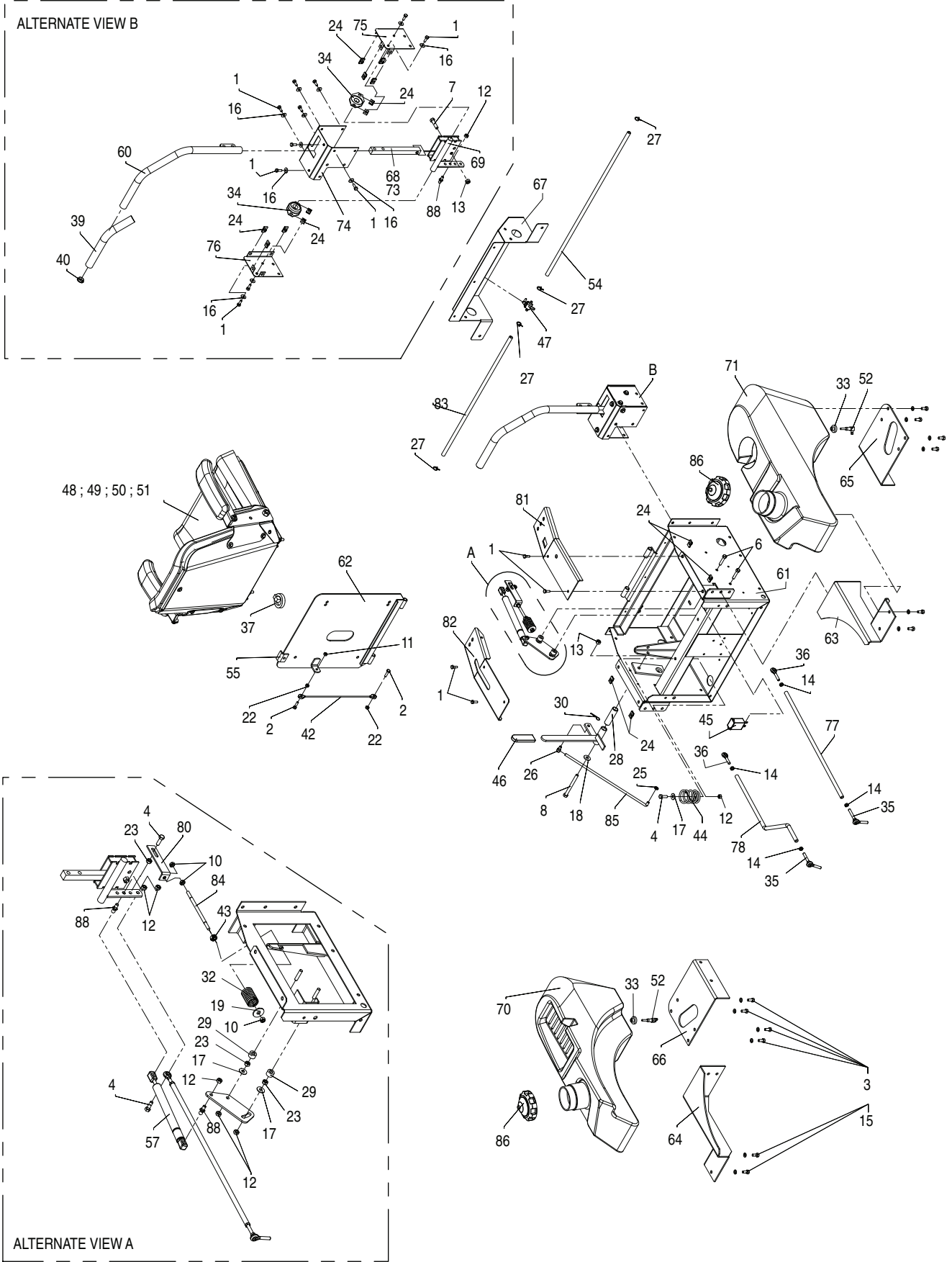

Seatframe Components

#	PART NO.	QTY	DESCRIPTION
1	100252	28	1/4-20 X 3/4 HHCS
2	100254	8	1/4"-20 X 1" HEX BOLT
3	100271	19	5/16-18 X 3/4 HHCS
4	100273	8	5/16-18 X 1 HHCS
5	100274	4	5/16-18 X 1-1/4 TAP BOLT
6	100275	2	5/16-18 X 1-1/2 HHCS
7	100294	2	3/8-16 – 1-1/2 HHCS
8	100303	2	3/8-16 X 4 HHCS
9	102000	3	#12-24 X 5/8 SELF TAP. SCREW
10	104253	2	5/16-24 NYLOC NUT
11	104255	2	1/4"-20 NYLOC NUT
12	104256	33	5/16-18 NYLOC NUT
13	104257	3	3/8"-16 NYLOC NUT
14	104752	4	5/16-24 JAM NUT
15	105005	10	5/16 LOCKWASHER - HEAV
16	105256	28	1/4 STD. FLATWASHER
17	105258	4	5/16 STD. FLATWASHER
18	105260	1	3/8 WASHER - STD FLAT
19	105261	2	3/8 ANS. TYPE B FLATWASHER
20	107503	2	5/16-18 X 3/4 CARR. BOLT
21	107520	2	5/16-18 X 1-3/4 CARR BOLT
22	109000	8	1/4"-20 WHIZ LOCK NUT
23	109001	4	5/16-18 WHIZLOCK NUT
24	109015	24	1/4-20 NUT CLIP
25	153045	1	5/16 PUSH NUT
26	363029	1	.312 ROD SWIVEL
27	363098	8	GAS LINE CLAMP - DSL
28	363105	1	BUSHING
29	363113	4	SPACER
30	363165	1	#3 ISSCO HAIRPIN COTTER (#2)
32	373054	2	SPRING
33	393042	2	GROMMET
34	423140	4	3/4 ID 2 BOLT BEARING
35	423160	2	5/16-24 BALL STUD
36	453082	2	5/16 ROD END
37	523030	1	SEAT SWITCH
38	523031	1	PTO SWITCH
39	523032	2	HANDLE GRIP
40	523033	2	HANDLE PLUG
41	523034	1	PARK SWITCH
42	523044	1	SEAT CABLE

Seatframe Components

#	PART NO.	QTY	DESCRIPTION
43	523112	2	5/16 CLAMP COLLAR
44	523278	2	SEAT SPRING
45	523283	1	HOUR METER
46	582048	1	PARK LEVER w/ GRIP
47	583302	1	FUEL VALVE - DSL
48	583077	1	SEAT LT. GREY W/TRACK
49	583089	1	SEAT CUSHION
50	583090	1	BACK CUSHION
51A	583242	1	ARM REST PAD - LH
51B	583243	1	ARM REST PAD - RH
52	583183	2	FUEL TANK ADAPTER
55	583224	1	SEAT STOP
56	583401	1	BATTERY MOUNT
57	583415	2	DAMPENER
58	583438	2	ADJUSTMENT PLATE
60	592002	1	CONTROL HANDLE - RH
60	592004	1	CONTROL HANDLE - LH
61	592008	1	SEAT FRAME WELDMENT
62	592010	1	SEAT PLATE WELDMENT
63	592012	1	RH REAR TANK MT.
64	592014	1	LH REAR TANK MT.
65	592016	1	FRONT TANK MOUNT – RH
66	592018	1	FRONT TANK MOUNT – LH
67	592020	1	CONTROL PANEL
68	592060	2	HANDLE MOUNT WELDMNT-LH
69A	592024	2	CONTROL PIVOT RIGHT
69B	592026	1	CONTROL PIVOT LEFT
70	593001	1	FUEL TANK/FENDER - LH
71	593002	1	FUEL TANK/FENDER - RH
72	593008	2	1-1/2" GROMMET
73	593010	2	HANDLE MOUNT BAR
74A	593022	2	RH CONTROL MOUNT
74B	593024	1	LH CONTROL MOUNT
75	593026	2	RH CONTROL COVER
76	593028	2	LH CONTROL COVER
77	593032	1	RH CONTROL LINK
78	593034	1	LH CONTROL LINK
79	593048	1	SWITCH MOUNT – NEUTRAL
80	593058	2	NEUTRAL INDICATOR
81	593067	1	RH TANK PANEL
82	593068	1	LH TANK PANEL

Seatframe Components

#	PART NO.	QTY	DESCRIPTION
84	823127	2	NEUTRAL LINK
85	823132	1	PARK BRAKE LINK
87	823194	1	ALARM
86	583463	2	DEISEL CAP - LARGE
88	823221	4	BALL STUD
89	583480	1	FUEL LINE - ILS (1/4 X 13")
90	583435	1	FUEL LINE - RETURN DSL (1/4 X 66")
91	583184	2	FUEL LINE - ENG (1/4 X 58")
92	523045	1	FUEL LINE - (5/16 X 15")
93	583186	2	FUEL LINE - (1/4 X 29")
94	603032	2	FUEL LINE - (1/4 X 24")

NOTES:

Hydraulic Components

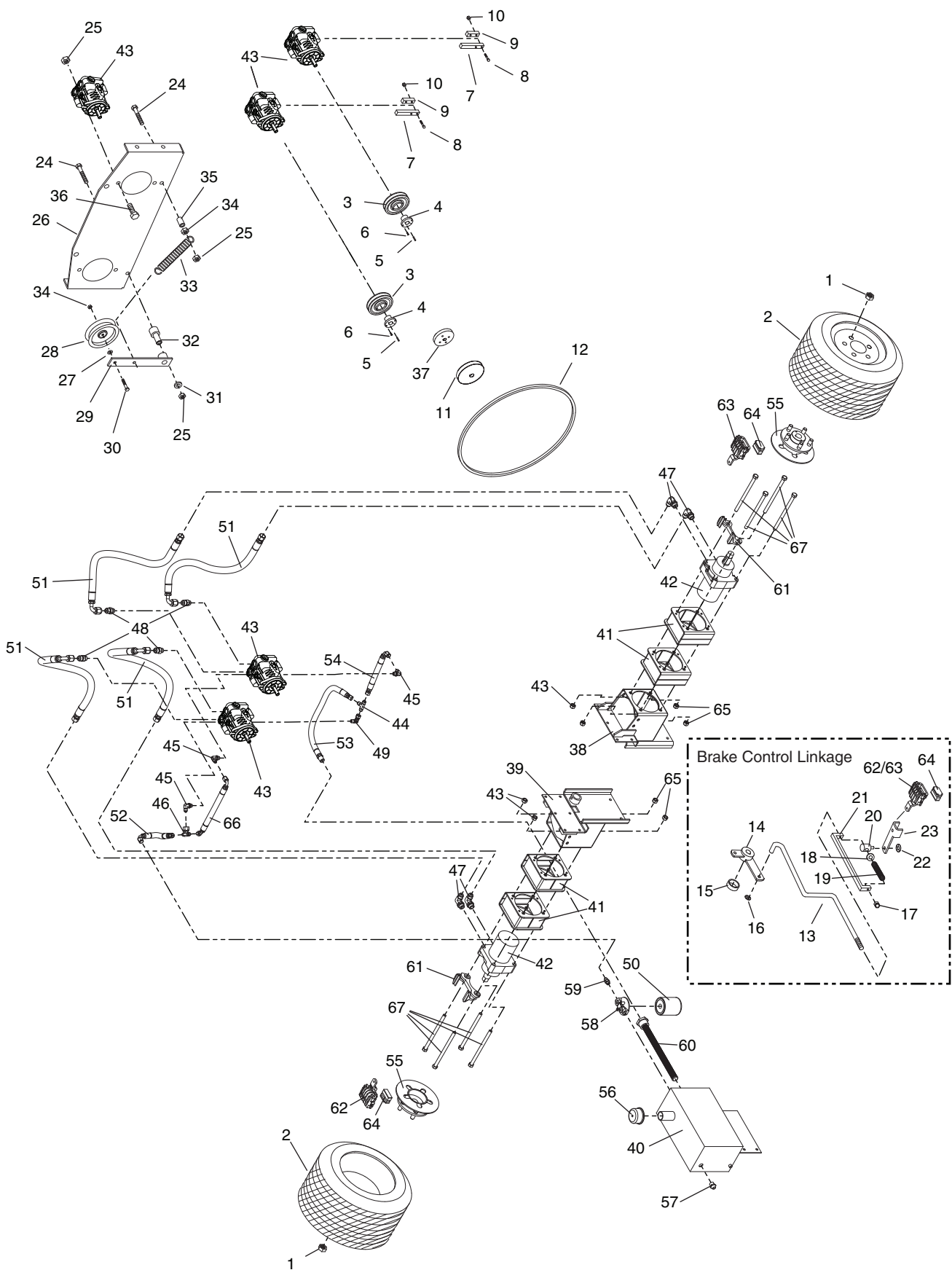

Hydraulic Components

#	PART NO.	QTY	DESCRIPTION
1	103023	10	LUG NUT
2	583055	2	DRIVE WHEEL (COMPLETE)
2A	583059	X	DRIVE TIRE (24 X 12 X 12)
2B	583487	X	BAR LUG TIRE (23 X 10.5 X 12)
2C	583058	X	RIM W/ VALVESTEM
3	583382	2	PUMP PULLEY
4	423178	2	15 MM TAPER HUB
5	453102	2	PUMP KEY
6	100252	2	1/4"-20 X 3/4" HEX BOLT
7	823104	2	CONTROL BAR
8	100257	4	1/4"-20 X 1 3/4" HEX BOLT
9	453090	2	CLAMP BAR
10	104255	6	1/4"-20 NYLOC NUT
11	583200	1	PUMP PULLEY
12	583385	1	PUMP BELT SML PUMP
13A	583042	1	RIGHT HAND BRAKE ROD
13B	583044	1	LEFT HAND BRAKE ROD
14	422049	1	BRAKE CRANK
15	373086	1	BLADE SPACER
16	104256	6	5/16" PUSH NUT
17	593116	2	BRAKE SPRING NUT
18	105257	2	5/16" SAE FLAT WASHER
19	523024	2	DECK DR. SPRING
20	423130	2	PARK BRAKE SWIVEL
21	593114	2	PARK BRAKE STRAP
22	363177	2	3/8" PUSH NUT
23	583190	2	BRAKE ARM
24	100300	2	3/8"-16 X 3" HEX BOLT
25	104257	32	3/8" NYLOC NUT
26	583328	1	PUMP PLATE -MCBBDP10
27	105260	13	3/8" FLAT WASHER
28	823351	1	PUMP DRIVE IDLER
29	422025	1	TENSIONER W/BUSHING
X	523111	X	BUSHING (SERVICE)
30	100294	2	3/8"-16 X 1 1/2" HHCS
31	373089	2	RETAINING WASHER
32	423175	1	IDLER PIVOT
33	583144	1	PUMP IDLER SPRING
34	109007	2	3/8"-16 WHIZLOCK NUT
35	393070	1	IDLER SPACER
36	100293	1	3/8 X 1 1/4 HHCS

Hydraulic Components

#	PART NO.	QTY	DESCRIPTION
37	583274	1	FRONT DRIVE ADAPTER
38	592102	1	RH MOTOR MT. WLDMNT - ML
39	592104	1	LH MOTOR MT. WLDMNT - ML
40	583049	1	OIL RESERVOIR
41	582031	4	MOTOR SPACER WLDMNT
42	593211	2	WHEEL MOTOR
43	593210	2	14 cc PARKER PUMP
44	453020	1	CROSS ADAPTER
45	453074	3	90° ADAPTER
46	453106	1	SWIVEL TEE
47	593208	4	LARGE MOTOR ADAPTER
48	593209	4	LARGE PUMP ADAPTER
49	453109	1	SWIVEL ELBOW
50	423361	1	OIL FILTER
51	593207a	4	LARGE MOTOR HOSE
52	593212	1	PUMP to FILTER ML
53	453025	1	HOSE 19in
54	583241	1	HOSE – PUMP – PUMP ZP
55	582008	2	WHEEL HUB WLDMNT
56	423165	1	OIL BREATHER CAP
57	423065	1	OIL EYE
58	423064	1	FILTER HEAD
59	583442	1	FILTER ADAPTER
60	583132	1	SUCTION SCREEN
61	583040	2	CALIPER MOUNT
62	583039	1	LEFT HAND BRAKE CALIPER
63	583038	1	RIGHT HAND BRAKE CALIPER
64	583511	2	BRAKE PAD KIT
65	104259	8	1/2-13 NYLOCK NUT
66	423373	1	PUMP FEED LINE - Z
67	100343	8	1/2-13 x 8 HHCS

NOTES:

Electrical Components

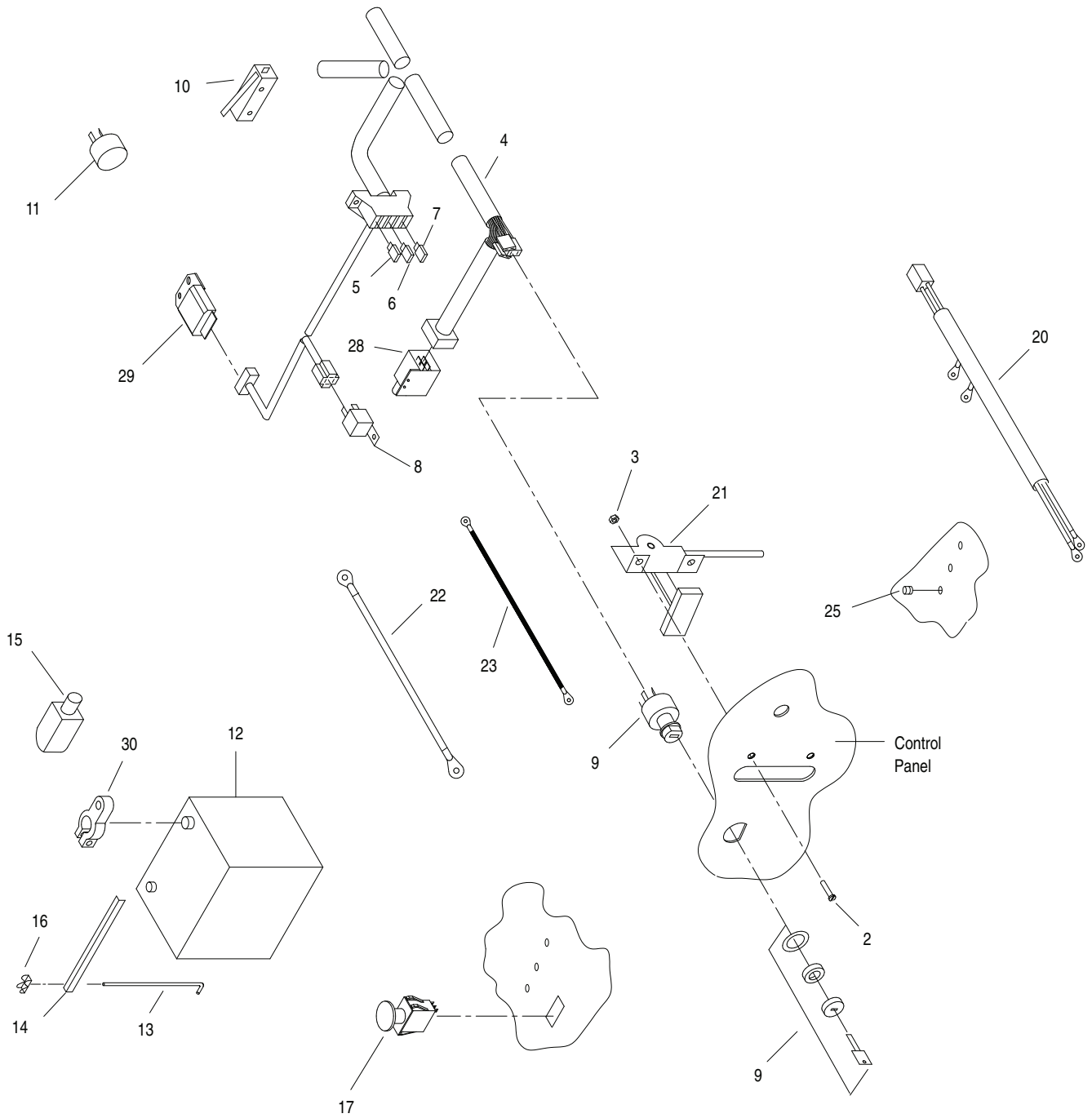

Electrical Components

#	PART NO.	QTY	DESCRIPTION
2	101039	6	#10-24 X 5/8" PAN HEAD BOLT
3	104252	6	#10-24 NYLOC NUT
4	593051	1	WIRE HARNESS - 950D-MC
5	583502	1	30 AMP FUSE
6	523146	1	15 AMP FUSE
7	523147	1	10 AMP FUSE
8	523042	3	RELAY
9	423027	1	IGNITION SWITCH ASSEMBLY
10	593041	1	NEUTRAL SWITCH
11	823194	1	ALARM
12	523050	1	12 VOLT BATTERY
13	423172	2	BATTERY HOLD DOWN
14	583403	1	BATTERY ANGLE - IL3
15	583409	1	POSITIVE BATTERY BOOT
16	109017	2	1/4"-20 WING NUT
17	523031	1	PTO SWITCH
20	583276	1	ENGINE WIRE HARNESS DSL
21	593045	1	THROTTLE CONTROL
22	823196	1	POSITIVE CABLE
23	823197	1	NEGATIVE CABLE
25	523036	5	WARNING LIGHT
28	523034	1	PARK SWITCH
29	583423	1	TIME DELAY MODULE
30	583429	2	BATTERY TERMINAL

NOTES:

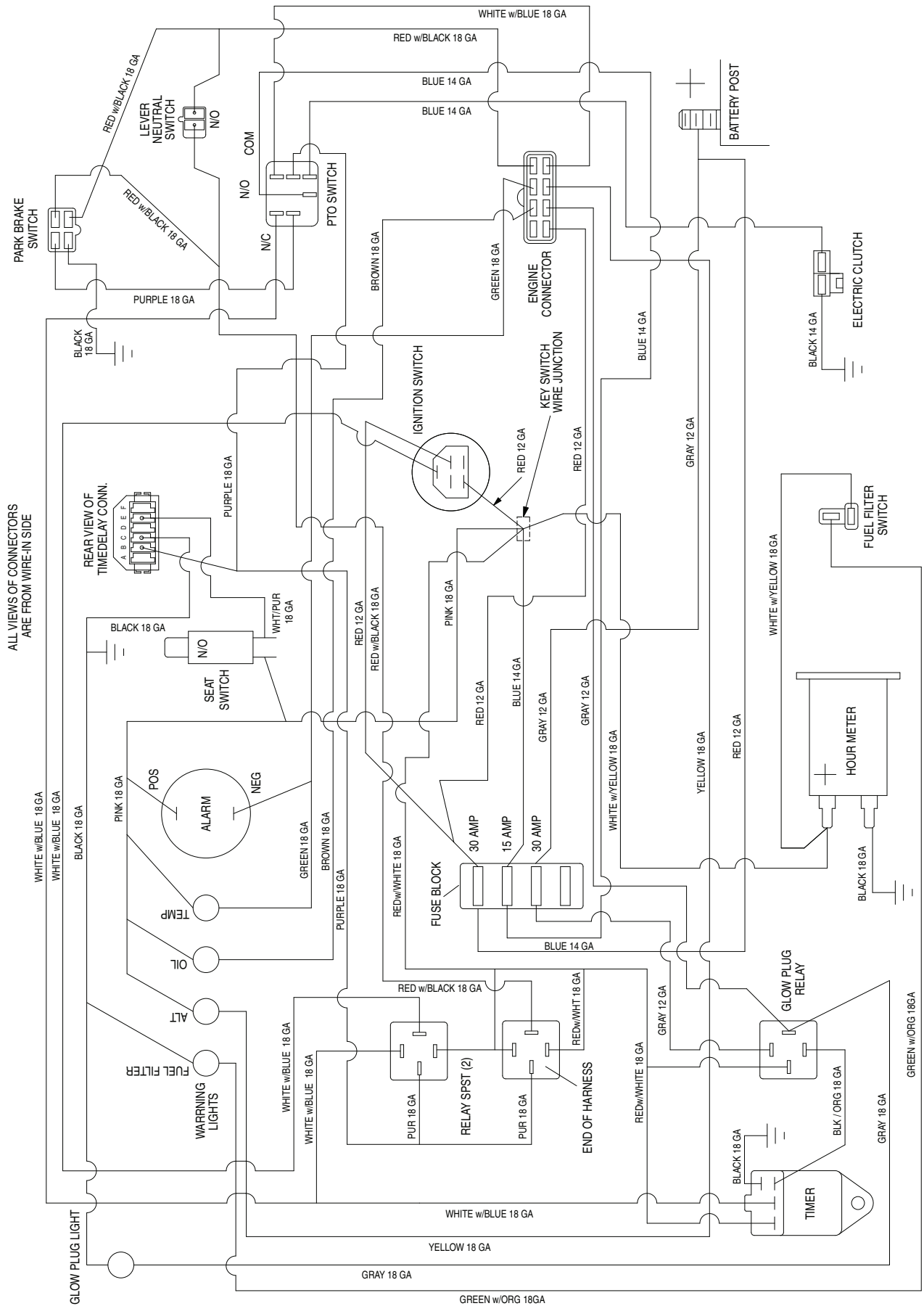

ALL VIEWS OF CONNECTORS ARE FROM WIRE-IN SIDE

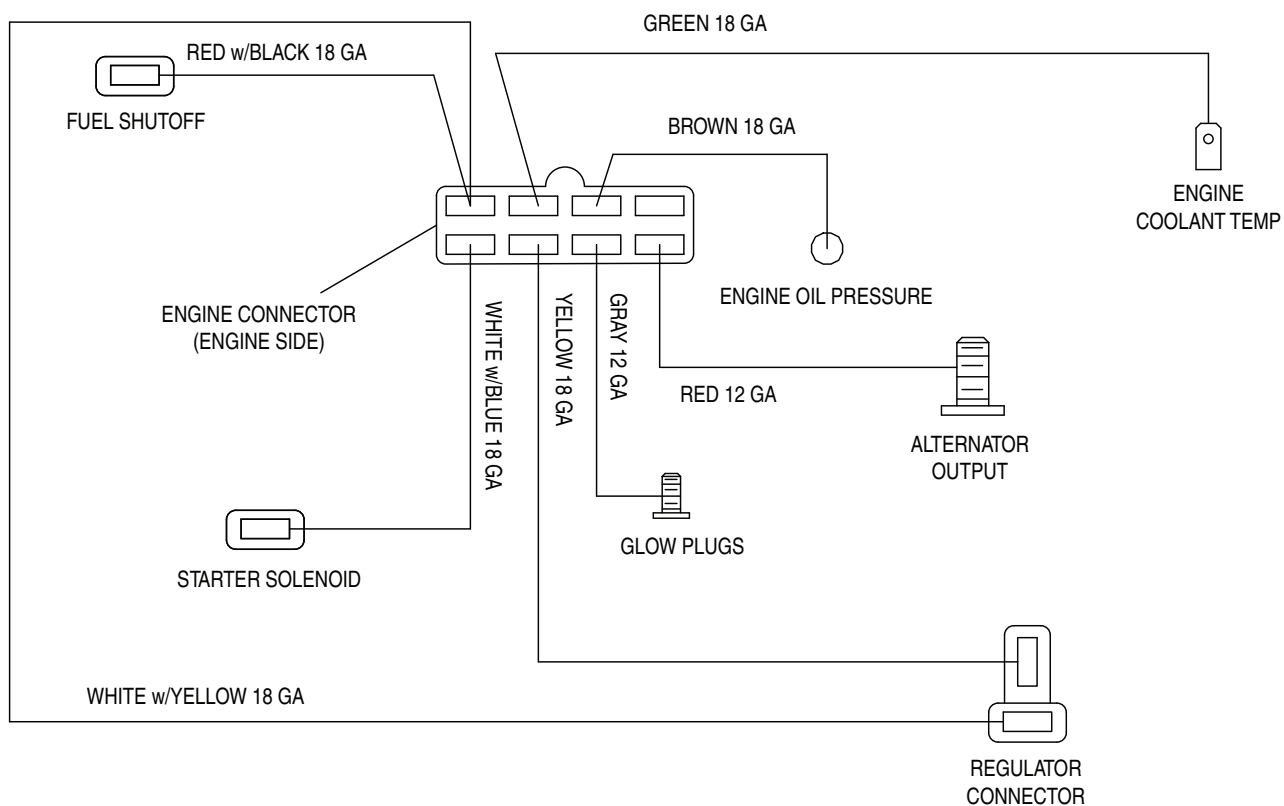

ENCORE PART #: 583276

ENGINE WIRE HARNESS FOR 61B850P ; 26 HP BRIGGS - DIESEL

ENGINE WIRE HARNESS FOR 72B850P ; 26 HP BRIGGS - DIESEL

ENGINE WIRE HARNESS FOR 72B850ZP ; 26 HP BRIGGS - DIESEL

ENGINE WIRE HARNESS FOR B850PFC ; 26 HP BRIGGS - DIESEL

ENGINE WIRE HARNESS FOR 61B27LD ; 27 HP BRIGGS - DIESEL

ENGINE WIRE HARNESS FOR 72B27LD ; 27 HP BRIGGS - DIESEL

Decal List



1

ENCORE

2, 3, 4



5

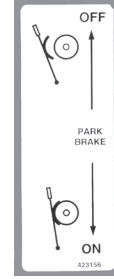

6

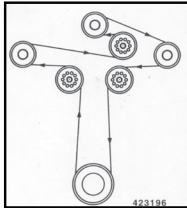

7

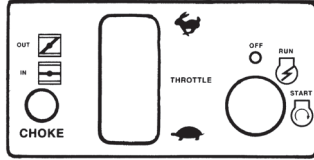

8



9

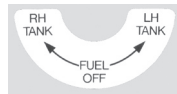

12

PROWLER

14, 21



10

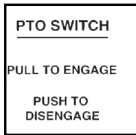

11

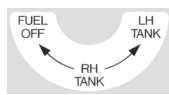

17



18

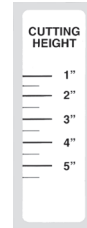

19



15

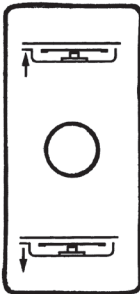

16

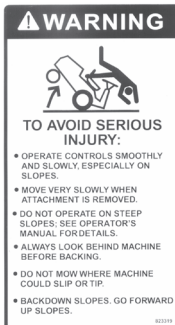

23



24

DIESEL

20

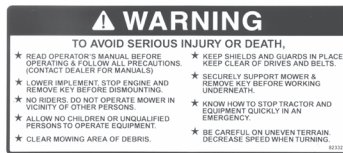

25



26



22



28



29



27



30



31

Decal List

#	PART NO.	DESCRIPTION
1	363023	DANGER DECAL
2	363231	LARGE ENCORE LABEL
3	363243	ENCORE DECAL
4	363265	SMALL ENCORE LABEL
5	423155	RIDER CAUTION DECAL
6	423156	PARK LEVER DECAL
7	423196	BELT ROUTING DECAL
8	423197	CONTROL DECAL
9	453010	OIL DECAL
10	523020	LIGHT DECAL
11	523021	PTO DECAL
12	583023	LABEL – FUEL VALVE
13	XXXXXX	MOLDED INTO TANK (No Decal Replacement)
14	583088	PROWLER - BLK DECAL
15	583192	PRO-61" DECAL
16	583232	DECAL – UP- DOWN
17	583280	FUEL VALVE LABEL – DSL
18	583372	GLOW PLUG DECAL
19	583416	CUT GAGE DECAL
20	583441	DIESEL LABEL
21	583443	PROWLER DECAL - RED
22	823318	FUEL TANK DECAL
23	823319	TIP OVER – WARNING
24	823320	BATTERY - WARNING DECAL
25	823321	OPERATING - WARNING
26	823322	ROTATING PARTS – DANGER
27	823323	ROTATING PARTS - WARNING
28	823324	SHIELD - DANGER
29	823325	THROWN OBJECTS - DANGER
30	823326	DISCHARGE - WARNING
31	823327	DISCHARGE - DANGER

NOTES:

Notes

