

Installation Instructions

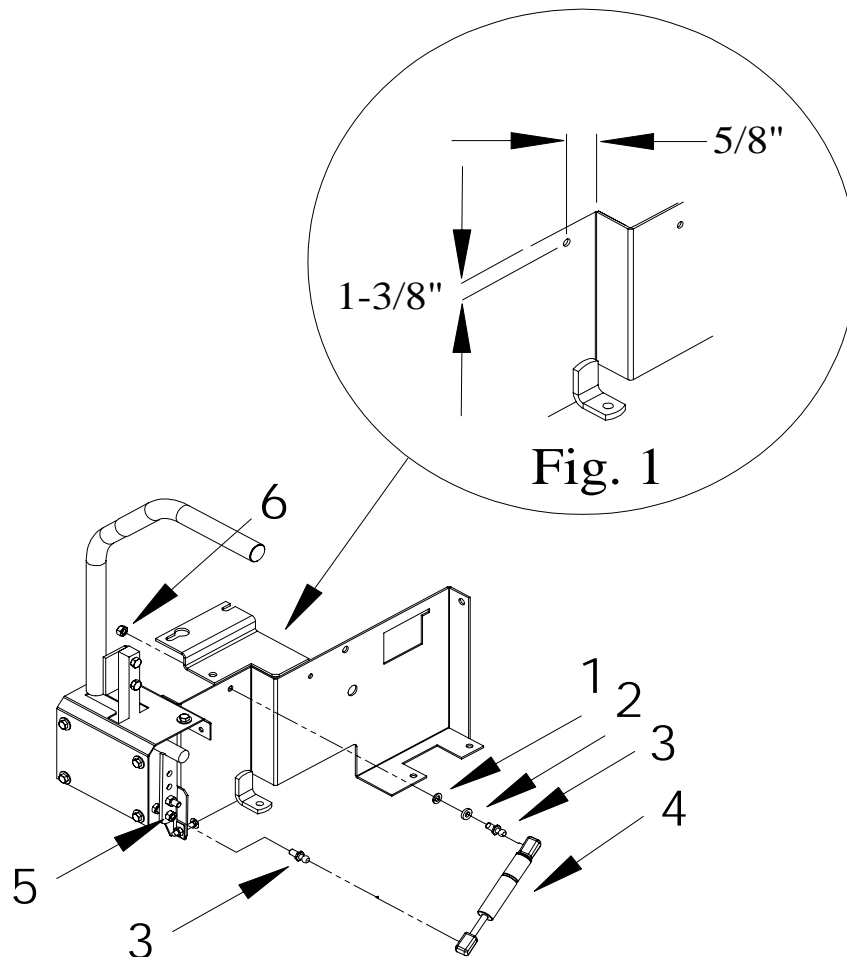

Details:

When installing the Z-Rider Dampener Kit, a hole must be drilled in each side of the seatframe. Using a 21/64" drill bit, measure down vertically from the top of the seatframe 1-3/8" and over horizontally 5/8" from the corner of the seatframe and drill a hole at that spot as shown in figure 1.

Once the holes have been drilled, the dampener cylinder may be fastened to the frame. The 10mm ball stud will slide through the cable anchor spacer and 5/16 lockwasher before passing through the wall of the seatframe. The 5/16 whizlock nut will fasten to the ball stud on the outside of the seatframe wall. Attach the dampener cylinder to the ball stud.

The front end of the dampener cylinder will attach to the 10mm ball stud which is fastened to the bottom hole of the control pivot. You will need to remove the existing 5/16 bolt and 5/16 nyloc nut. Re-use the 5/16 nyloc nut to fasten the 10mm ball stud to the control pivot. Attach cylinder to ball stud.

Item #	Qty	Part #	Description
1	2	105005	5/16 Lockwasher
2	2	253075	Cable Anchor Spacer
3	4	823221	10mm Ball Stud
4	2	823201	Dampener Cylinder
5	2	104256	5/16 Nyloc Nut
6	2	109001	5/16 Whizlock Nut