

# **X-TREME™**

## **ROPS ASSEMBLY INSTRUCTIONS**

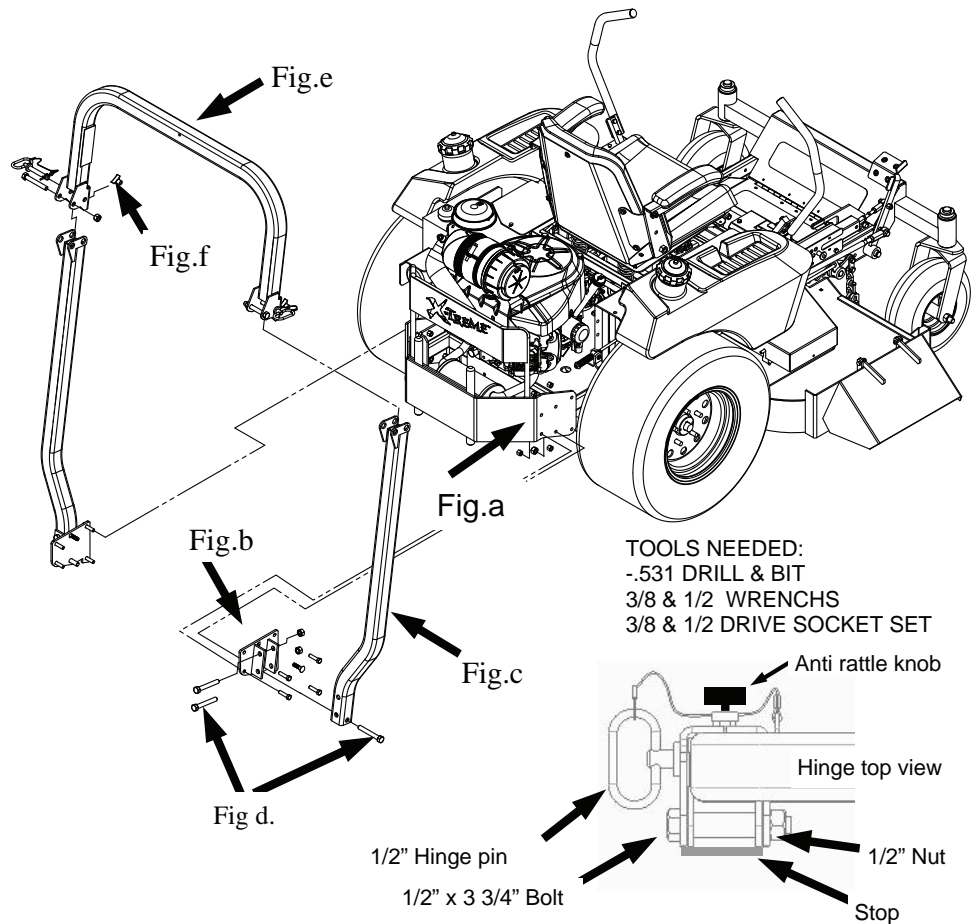

933229



1. Remove (6) 3/16 bolts on the bumper assembly. (a)
2. Attach right side ROPS mount (b) using (5) 3/16-16x1 1/2 bolts, washers and nuts. Washers assemble under nuts. Lower / middle hole does not receive a fastener at this time. Lightly secure fasteners.
3. Using mount as a template, drill lower / middle to .531
4. Assemble RH side ROPS post (c) into mount channel using (3) 1/2 x 3 1/2 bolts, washers and nuts. See fig, (d)
5. Repeat steps 1,2,3, & 4 to the left side. Do not tighten.
6. Assemble ROPS top loop (e) to ROPS posts see hinge top view.
7. Assemble anti rattle knobs fig, (f).
8. Tighten all hardware.

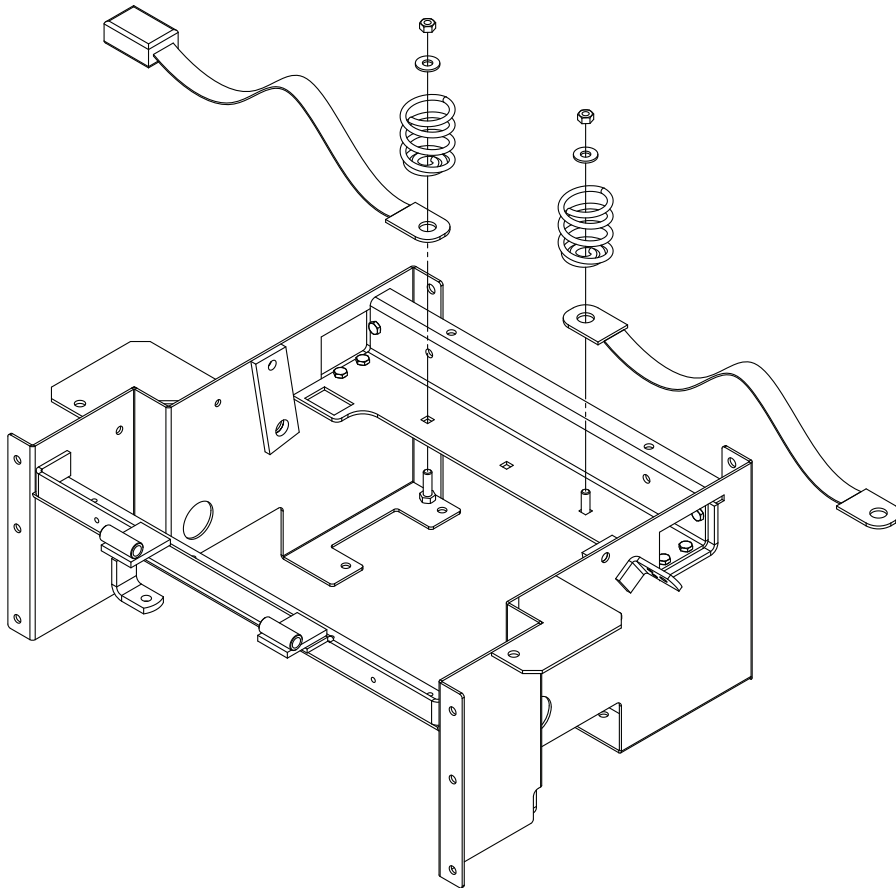

1. Remove suspension springs and reinstall with seatbelts as shown.

