



**K900PFC**

**OPERATORS  
MANUAL**





# ENCORE FRONT CUT RIDER

## General Safety Instructions

**YOUR MOWER IS ONLY AS SAFE AS THE OPERATOR!** Operator carelessness or error may result in serious bodily injury. Improper maintenance of the machine may also result in injury. Please read and follow these instructions on safe operation and be certain that anyone using this mower fully understands and follows these instructions.

1. Familiarize yourself with the controls and know how to stop the Rider and mower deck quickly.
2. Do not allow children to operate this machine. Do not allow adults to operate the machine without proper instructions.
3. Inspect your work area carefully. Remove debris from the area to be cut. Keep all bystanders away from the mowing area.
4. Avoid contact with moving parts. Keep hands and feet clear of the mower deck.
5. Never direct the discharge of material toward bystanders nor allow anyone near the machine while in operation.
6. The machine is not intended for highway or street use. Never carry passengers.
7. Never tamper with safety devices or guards. If a guard or safety device is damaged or removed, replace it before operating the Rider.
8. Handle gasoline carefully: use an approved gasoline container; fill the fuel tank to within 1" from the neck with good quality leaded or unleaded gasoline; never add fuel to the tank while the engine is running or hot; never fill the fuel tank indoors; wipe up spilled gasoline. Gasoline is highly flammable - **NO SMOKING.**
9. Drive levers must be in the neutral position and blade clutch must be disengaged before starting the engine.
10. Operator must wear proper shoes and clothing, which may also include safety glasses.
11. Mow only during daylight hours or under very good artificial light.
12. The safety shield over the grass discharge area must always be bolted in place and in the down position unless the grass catcher is being used.
13. If a solid object has been hit by the blades, stop the machine and check for damage. Repair or replace any damaged/broken part prior to restarting the engine.
14. To avoid burns, **DO NOT TOUCH** the engine or muffler immediately after operation.
15. Disengage blades when transporting and when crossing walks and gravel roads.
16. Do not mow close to drop-offs, deep ditches or other hazards. Do not stop or start suddenly when going uphill or downhill. Mow up and down the face of steep slopes; never mow across the face. If a steep hill must be ascended, **BACK** up the hill; drive forward when descending.
17. Reduce speed and exercise extreme caution on slopes and in sharp turns to prevent tipping or loss of control. Be especially cautious when changing direction on slopes.
18. **DO NOT** tow loads up hills or loads that are too heavy for the machine as it could make the front of the mower flip up.
19. When towing a heavy load, push levelers forward slowly.

## Assembly Instructions

**Remove tractor from crate. Lay out all the hardware and parts.**

1. Remove the tail wheel from the box and assemble the caster(s) with the clamp collar(s).
2. Remove the rear cover from the tractor by loosening the knobs.
3. Slide the tail wheel into the frame rails until the holes line up. Use (4) 3/8 x 1 HHCS, (4) 3/8 x 1 3/4 HHCS, and 8 nyloc nuts to bolt it together.
4. Reinstall the rear cover.
5. Use (4) 5/16 nyloc nuts and (4) washers to bolt the seat in place.
6. Install the control levers to the outside of the mount angle with (4) 5/16 x 3/4 HHCS and (4) 5/16 whizlock nuts. Adjust levers and tighten bolts.



# ENCORE FRONT CUT RIDER

## Before Operating - Reminders

Fill engine crankcase as per engine manufacture's manual. Engine **DOES NOT** have oil in crankcase from the factory. Add proper fuel to fuel tank, open valve by fuel pump. The battery is a **dry battery** and must be filled with the proper electrolyte.

Once you are familiar with the contents of this manual you are ready to mow with the finest mower built!

## Starting Engine

Throttle control, ignition switch and choke control are located on the right fender. Because of a built-in safety interlock system, your machine will not start unless the seat is occupied.

**TO START ENGINE:** occupy seat, set park brake, leave the motion control levers swung out, move throttle control lever halfway to operating position. Turn ignition key to start position to engage starter, release the key when the engine starts. Ignition switch is spring loaded and will return to run position automatically. Slowly return choke to run position once the engine has started.

## Stopping Engine

**TO STOP ENGINE:** move throttle lever to idle position and turn ignition key to off position. If engine has been working hard or is hot, allow engine to idle for a short period of time before turning off key. This practice will help cool engine before stopping.

**IN CASE OF EMERGENCY** engine may be stopped by turning ignition key to off position.



### CAUTION



Always remove key and set parking brake when leaving machine unattended even for just a few minutes. **PREVENT ACCIDENTS:** do not give children or unauthorized persons an opportunity to operate this machine.

## Controls

### SAFETY INTERLOCK SYSTEM

Your Encore Front Cut is equipped with a Safety Interlock System that is designed to help prevent possible serious injuries. Understanding and maintaining this system, is vital for safe operation.

#### To Start Engine:

1. Blades (PTO) must be off.
2. Control levers in neutral (swung out).
3. Park brake on.
4. Operator in seat.

#### The Engine Will Kill If:

1. The operator leaves the seat with:
  - a. The control levers out of neutral (swung in).
  - b. The blades on (PTO).
  - c. The park brake off.
  - d. All of the above.
2. The park brake is set before the control levers are in neutral (swung out).

**DO NOT OPERATE MOWER IF SAFETY SWITCHES ARE NOT OPERATING PROPERLY.**

## Correct Transmission Operation to Go Forward or Reverse

The Encore Rider is equipped with a separate pump and wheel motor for each wheel and are controlled with "Motion Control Levers," one for each wheel.

- To go forward, push both levers forward evenly.
- To go in reverse, pull back on both levers evenly.
- To change direction, slowly move levers to neutral and move the lever forward in the direction you want to go.
- The further the levers are moved away from the neutral position, the faster the machine will travel. To turn the Rider left or right, slow the speed of the wheel in the direction you want to turn.
- To stop the Rider, return both levers evenly to the neutral position.

**Warning:** The Engine Exhaust from this product contains chemicals known to the State of California to cause cancer, birth defects or other reproductive harm.



# ENCORE FRONT CUT RIDER

## Mowing Speed

The Encore Rider is designed to operate most efficiently at maximum blade speeds. The running speed of the machine should allow the mower blades to maintain this maximum speed while mowing across turf. Use a slower ground speed for cutting tall grass, grass which is heavy with moisture, or when mowing uphill. If ground speed is too fast, or blade speed is too slow, mowing will be uneven because mower blades will not be able to lift grass into cutting position as mower passes.

Throttle control regulates speed of engine as measured in RPM. This control **SHOULD NOT** be used to control ground speed.

## Maintenance and Service

1. Do not adjust mower or change attachments unless engine has been stopped and key has been removed.
2. Good maintenance, wiping up gasoline and oil spills, will reduce potential fire hazards.
3. To insure that the mower will remain in safe operating condition, check and tighten all bolts, nuts and screws. Especially make certain the blade bolt/nuts are always tightened properly.
4. Never adjust governor on engine to a faster speed. Engine RPM is adjusted to the proper setting by the engine manufacturer.
5. Allow time for engine to cool down prior to storing mower. Do not store mower or gasoline near any open flame or where gasoline fumes may be ignited.
6. Always replace worn or broken parts with genuine Encore repair parts purchased from an authorized Encore dealer. Using anything other than Encore repair parts may void all Encore factory warranties.



### CAUTION



Do not spill oil or grease on belts.

## Oil and Filter

Change the hydraulic system filter and reservoir oil between 50-100 hours the first time, every 500 hours thereafter. The hydraulic filter is located under the right fender.

Follow the installation instructions printed on the filter. Use only a high quality 20W50 API CD rated engine oil. Refer to the engine manual for engine lubrication recommendations.

## Tire Pressure

This vehicle has been designed to achieve maximum operator comfort and ride. This cannot be achieved without proper tire pressure. A low pressure gauge is required to check the front tires.

Front Tire: 15 psi

Drive Tire: 22 psi

Rear Tire: 25 psi

## Battery



### CAUTION



When servicing battery or any other part of electrical system, or if battery must be removed for any reason, always disconnect negative (ground) cable **FIRST** and reconnect it **LAST** to avoid possibility of electrical shorts.

At temperatures below 32°F (0°C), full charge state must be maintained to prevent cell electrolyte from freezing and causing permanent battery damage.

Maintain electrolyte level above plates in each cell by adding distilled water as necessary. The best time to add water is just prior to operating the mower so water will mix with the solution. *Do not over fill battery: electrolyte solution is corrosive and over filling can cause damage to surrounding metal parts.* Battery should be maintained at 1.265 gravity charge. When replacing battery after servicing, take care to reconnect cables exactly the way they were before removing the battery.

For longest service life, battery should be kept clean by wiping it off with a paper towel. Any corrosion around battery should be removed by applying a solution of one part baking soda to four parts water. A light coating of grease or petroleum jelly may be applied to all exposed terminal surfaces to prevent corrosion.



# ENCORE FRONT CUT RIDER

## Gearbox

### CHECKING DECK DRIVE GEARBOX FLUID LEVEL

- A. Rotate deck into the upright position.
- B. Remove the hex head plug at the low end of the gearbox housing. (Plug closest to the drive shaft.)  
The fluid level should be level with the bottom of the threaded hole.

### CHANGING FLUID IN DECK DRIVE GEARBOX

(Annually or every 500 hours)

- A. Rotate the deck into the upright position and remove drain plug from bottom edge of gearbox.
- B. Lower deck to drain fluid.
- C. When the fluid has drained from the gearbox, raise deck back up and fill with Mobil SHC 630 synthetic motor oil (or equivalent). Fill to the bottom of the hole that the plug was removed from.
- D. Reinstall drain plug.

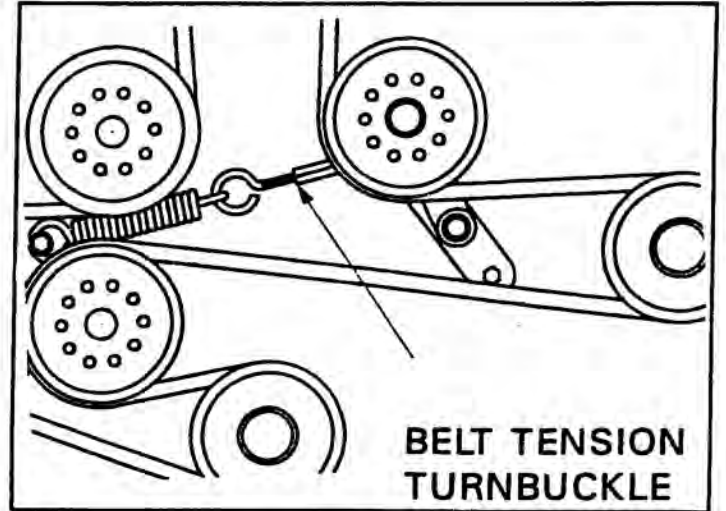

Fig. 2 - Turnbuckle Location

## Lubrication

The following recommendations on lubrication should be adhered to. Environmental conditions may be cause to vary frequency.

Before each use:

- clean engine chaff screen
- check engine oil and tires

Every 100 hours:

- lubricate chassis
- lubricate front wheels
- lubricate drive and pump control pivot points
- check belt tension

## Belt Adjustment

**Remove key from the ignition switch.** The deck drive belt, which may be accessed by removing the belt cover (see fig. 2) has a turnbuckle assembly to adjust spring tension. Spring tension should be maintained at 4" of spring stretch measuring the spring coils. By turning the turnbuckle clockwise it will increase tension, counter-clockwise will decrease tension.

## Neutral Adjustment - Drive

1. Raise the drive wheels of the power train off of the ground. Safely block the frame in this position so it is secure.
2. (a) Check to be sure the spring loaded neutral arm is in sync with the control levers. (Pull back on the levers and let go; they should return to the proper neutral location). This is adjusted by locking the control lever in the neutral position (swung out) and loosening the 3/8" retaining bolt on each neutral arm (located inside the seat frame). Allow the arm to adjust to the lever and retighten the bolt.
2. (b) With the operator in the seat, start and run the engine, leaving the control levers in the neutral position. Release the park brake. Check rear wheels for neutral creep (any rotation).
3. Stop engine, engage park brake and remove the cover between the engine and the seat frame. All





# ENCORE FRONT CUT RIDER

neutral creep (rotation) should be adjusted out of the drive. This adjustment is performed at the adjustable pump link on each corresponding pump. (See illustration) Loosen the jam nut between the ball stud and the control rod. Turn the ball stud in if there is forward rotation at the wheel and out if there is reverse rotation. Never adjust link more than 2 turns. Retighten jam nut and start engine.

4. If wheel still creeps, repeat procedure in step 3.
5. After final adjustment is made (make sure that the jam nut is secure on pump link), take unit for a test drive to check tracking.

## Tracking Adjustment

This will be done so the machine will drive in a straight line when steering handles are aligned with each other.

1. Return the wheels to the ground and drive the mower to check tracking at low and full speed.
2. If pumps are properly neutralized, intermediate speed tracking is only affected by tire size and/or tire pressure.
3. Full speed tracking is determined by the stop cams located behind each neutral arm under the fenders. (See illustration). You may speed up or slow down a fast or slow pump motor by rotating the cam away from or towards the neutral arm.

## Drive Adjustments

Steering and motion controls should be uniform in all forward and reverse speeds. Levers should automatically return to neutral when released.

**\*\*\*\*\*CAUTION\*\*\*\*\* TURN OFF ENGINE  
BEFORE MAKING ADJUSTMENTS**

## Test Drive Operations

Check air pressure in tires. Equal tire pressure is critical for proper drive operation.

Check linkage for excessive play:

1. Raise drive wheels off ground. Safely block the frame in this position.
2. Put control levers in neutral lock position (control levers swung outward).
3. Start engine. Wheels should not rotate. If one or both drive wheels are turning, perform procedures under "Neutral Adjustments" for side(s) that wheel turns.

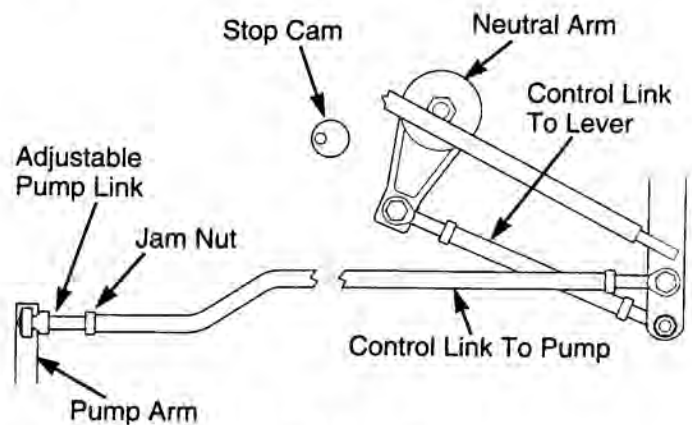

## Leveling The Deck

The deck comes from the manufacturer pre-leveled. If the deck does not appear to be cutting level, follow this procedure.

1. Set all tire pressures to correct specifications.
2. Place machine on a level slab of concrete.
3. Wear heavy gloves and move blades by hand so all of the blades are pointed in the same direction. (See illustration) Measure from the blade tip (beveled edge) to the ground on all three blades. If there is more than 3/16" difference from one side to the other, the deck should be leveled.
4. Remove the tension adjust bolt from the high side. This takes the tension off the deck lift spring. Remove the clevis pin from the rear of the lift spring rod. The lift spring rod is two parts, one threaded into the other. Turn the lift spring rod counter-clockwise two turns. Reassemble lift spring completely and release. Repeat as required to achieve a difference of no more than 3/16" from one side to the other.



# ENCORE FRONT CUT RIDER

## Deck Installation

- A. Move deck to the front of the tractor unit. With foot plate raised, slide the drive shaft onto the gearbox after installing the 1/8 x 1" key onto the gearbox shaft (be careful not to over extend the power shaft). Using the 1/2 x 3/8" set screws tighten shaft to 30 ft. lbs.
  - B. Align the deck hanger bars on tractor with the deck mount plates on the deck. Now place 7/8 x 3 1/2" pins in holes and install cotter pin.
  - C. Rotate deck lift lever back toward the tractor and install the 3/8 x 2" pin into the deck lift bar in the lowest cutting position.
  - D. Rotate the deck lift handle into the lowest possible position and install the two 3/8 x 3" pins into the deck hanger brackets.
- Rotate the deck lift handle back toward the tractor and push quick release pin into slot on deck lift adjustment plate.
- F. You may then achieve the desired cutting height by changing the pin position in the deck lift bar.

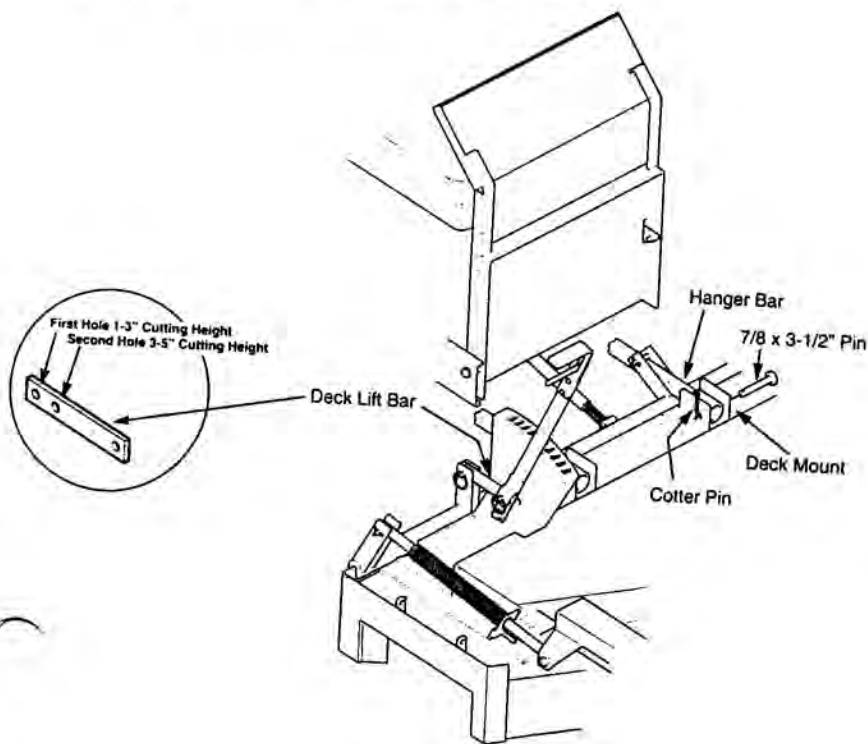

## Mower Deck Tilt-Up Procedure

- A. Fold steering levers into operating position.
- B. Raise the foot deck into vertical position and lock into place.
- C. Set ring pin into second slot on deck lift bar (Hole closest to deck lift handle - Refer to page 21). At this time you must also pull back quick release pin in deck lift handle so that it just engages the lift handle and is no longer running in the adjuster slot. Set deck lift handle in the lowest possible position.
- D. Remove the deck arm ring pins at the deck arms.
- E. Release the lift handle to relieve the pressure off of the deck lift bar ring pin. Remove the lift bar pin. (This may require weight on the front of deck).
- F. Move the deck lift handle to the stow position. Lock in place with the quick release pin.
- G. Lift up on the front of the deck until deck rotates past 90 degrees.

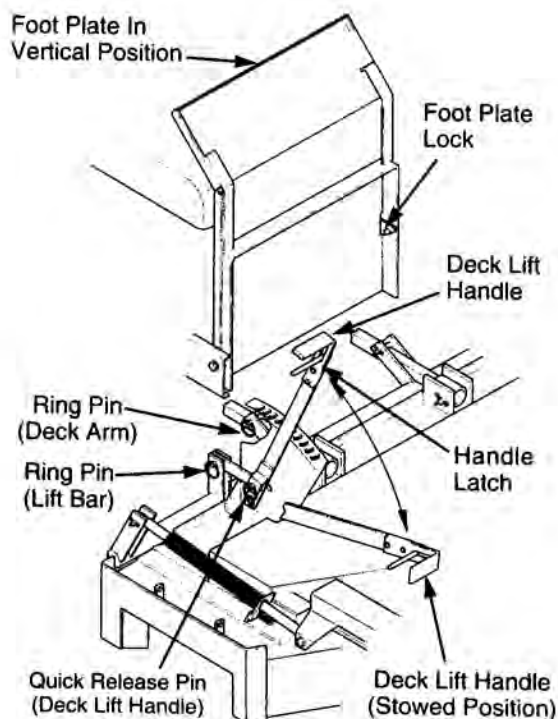

# KAWASAKI WIRING HARNESS

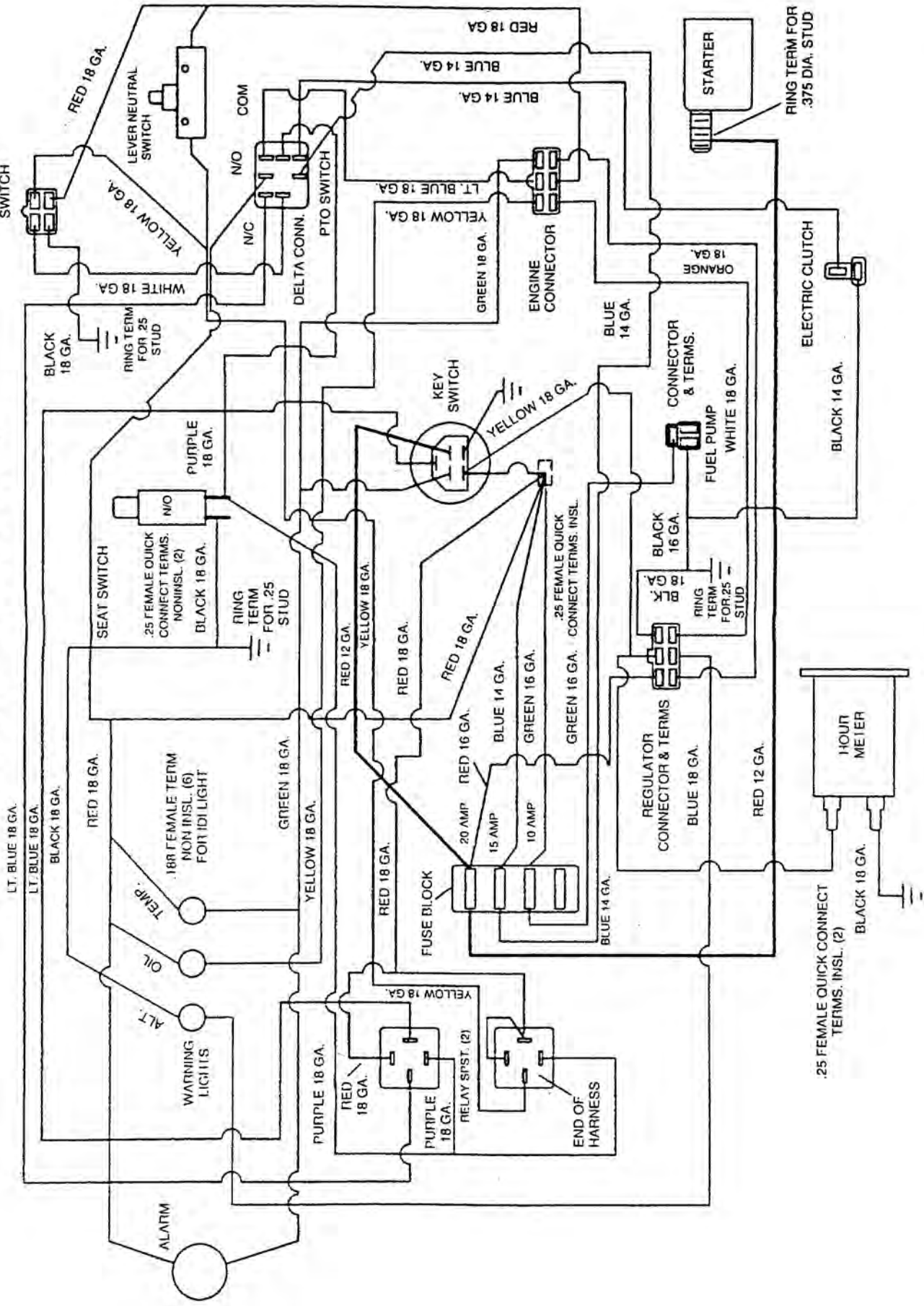



# KOLHER WIRING HARNESS

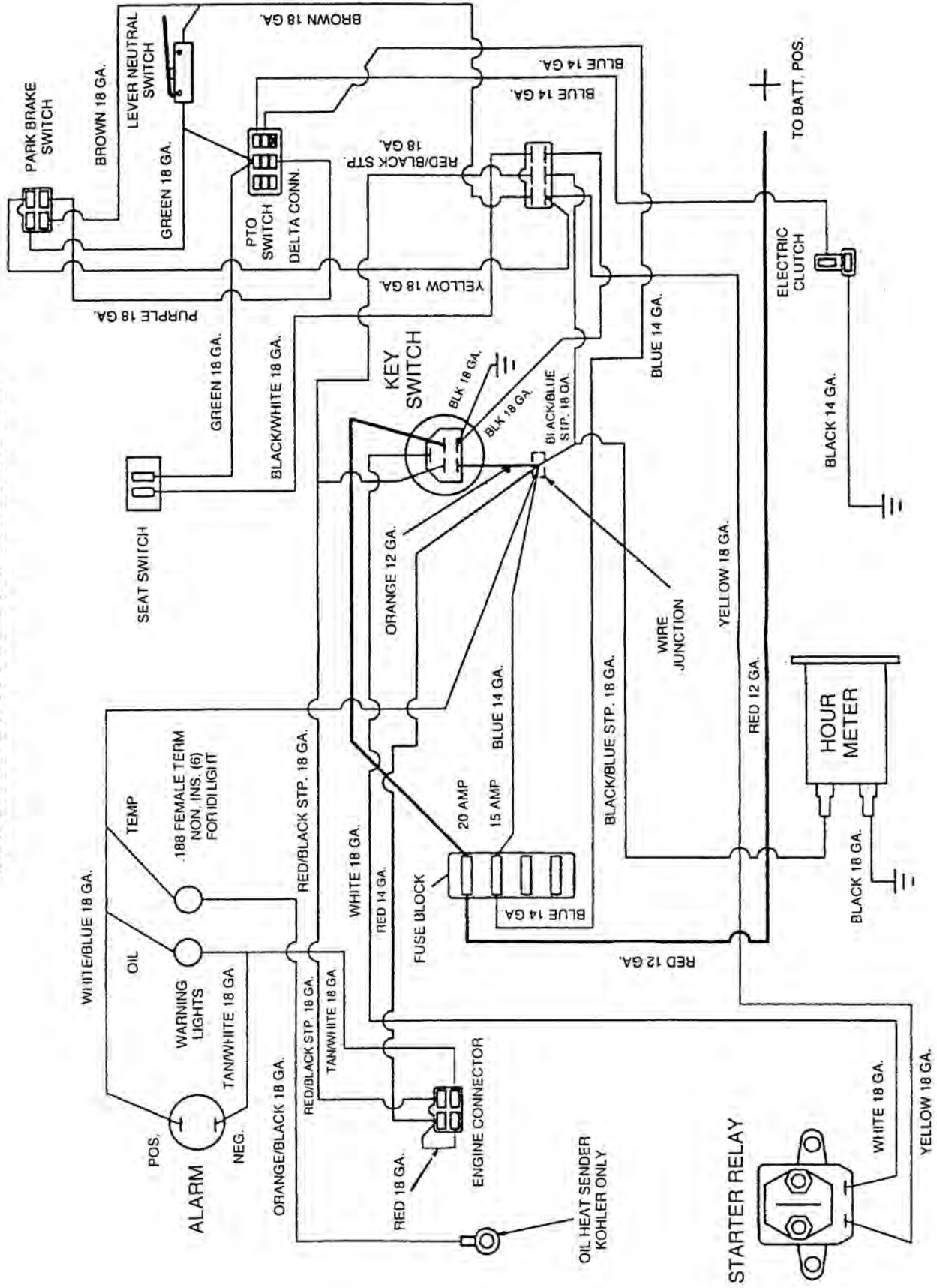



# ENCORE FRONT CUT RIDER

## ENCORE Warranty

This warranty extends to the original retail purchaser only and commences on the date of original retail purchase.

Any part of the Encore commercial Rider manufactured by Encore Mfg. Co., Inc. and found in reasonable judgment of Encore Mfg. Co., Inc. to be defective in material or workmanship, will be repaired or replaced by an authorized Encore Mfg. Co., Inc. dealer without charge for parts and labor.

The Encore Rider, including any defective part, must be returned to an authorized Encore service dealer within the warranty period. The expense of delivering the Rider to the dealer for warranty work and the expense of returning it back to the owner after repair or replacement will be paid by the owner. Do not destroy or discard defective parts until claim has been approved. We reserve the right to request defective parts to be returned for inspection. DO NOT return parts unless requested. Should any part prove to be defective within the one year of original purchase (90 days for rental purposes), the parts will be replaced f.o.b. Beatrice, Nebraska, without charge, provided, if requested, the defective part is returned to us transportation charges prepaid. The responsibility of Encore Mfg. Co., Inc. in respect to claim is limited to making the required repairs or replacements, and no claim of breach of warranty shall be cause for cancellation or recession of the contract of sale of any Encore Rider. Proof of purchase will be required by the dealer to substantiate any warranty claim. All warranty work must be performed by an authorized Encore service dealer.

This warranty is limited to one year from the date of original retail purchase for any Encore Rider that is used for commercial purposes or 90 days rental.

This warranty does not cover any Encore Rider that has been subject to misuse, neglect, negligence, accident or that has been operated in any way contrary to the operating instructions as specified in the Operator's Manual. The warranty does not apply to any damage to the Rider that is the result of improper maintenance, or to any Rider parts that have not been assembled or installed as specified in the assembly instructions. The warranty does not cover any Rider that has been altered or modified so as to adversely affect the intended use of the product, its operation, performance or durability. In addition, the warranty does not extend to repairs made necessary by normal wear or by the use of parts or accessories which, in the reasonable judgement of Encore Mfg. Co., Inc. are either incompatible with the mower or adversely affect its operation, performance or

durability. This warranty DOES NOT cover the engine and battery, which are warranted separately by the engine and battery manufactures and for different periods of time.

Encore Mfg. Co. Inc., reserves the right to change or improve the design of any Rider without assuming any obligation to modify any Rider previously manufactured. Encore Mfg. Co., Inc.'s obligation under the warranty is strictly and excessively limited to repair or replacement of defective parts. Encore Mfg. Co., Inc. does not assume or authorize anyone to assume for them any other obligation. Some states do not allow limitation on how long an implied warranty lasts, so the above limitation may not apply to you.

Encore Mfg. Co., Inc. assumes no responsibility for incidental, consequential or other damages including, but not limited to expense of delivering the Rider to an authorized service dealer and expense of returning it back to the owner, mechanic's travel time, telephone or telegram charges, rental of a like product during the time warranty repairs are being performed, travel, loss or damage to personal property, loss of revenue, loss of use of the Rider, loss of time or inconvenience. Some states do not allow the exclusion or limitation of incidental or consequential damages so the above limitation or exclusion may not apply to you.

This warranty gives you specific legal rights, and you may also have other rights which vary from state to state.

**ENCORE MFG. CO., INC. CANNOT BE RESPONSIBLE FOR THE WAY YOU OPERATE, OR THE CONDITIONS IN WHICH YOU OPERATE THE RIDER. USE COMMON SENSE AT ALL TIMES.**



**ENCORE**  
MANUFACTURING CO., INC.

**Notes:**

