



OPERATORS MANUAL

ED34FS600V

ED34FS600VCA

CONTENTS

QUICK REFERENCE SHEET	5
GENERAL INFORMATION	6
BEFORE OPERATING.....	8
ASSEMBLY INSTRUCTIONS	8
STARTING ENGINE.....	8
STOPPING ENGINE.....	8
SAFETY INTERLOCK SYSTEM	9
CORRECT TRANSMISSION OPERATION	9
MOWING SPEED	9
SERVICE LOCATOR CHART	10
MAINTENANCE INFO.....	11
OIL AND FILTER.....	11
TIRE PRESSURE.....	11
LUBRICATION	11
BATTERY	11
BELT ADJUSTMENT	12
BYPASS VALVE	12
DECK HEIGHT ADJUSTMENT.....	12
DECK LEVELING ADJUSTMENT	13
TRACKING ADJUSTMENT	13
MOWER BLADES.....	13
WIRING SCHEMATIC	14
CALIFORNIA EVAPORATIVE EMISSION CONTROL WARRANTY STATEMENT	15
ENCORE WARRANTY.....	17

QUICK REFERENCE SHEET

Engine		Pulleys		
Kawasaki Electric FS600V-S00		603070	RH Spindle Pulley	
		423262	LH Spindle Pulley	
Blades		533114	Tensioner Pulley-Blade	
423029	14" Blade		Drive Belt	
423014	14" Low Lift Blade	823351	Pump Tensioner Pulley	
423173	14" Mulch Blade	353101	Pump Drive Pulley	
423210	14" Super Hi-Lift Blade			
603035	20" Blade	Front Caster Bearings		
603055	20" Blade	423200	Bearing	
603056	20" Super Hi-Lift Blade	423201	Bearing Retainer	
Belts		Seat		
353111	Blade Drive Belt	353244	Seat	
353112	Pump Drive Belt	353245	Pad, Arm Rest	
Tires				
353231	Wheel/Tire Asm			
353239	Drive Tire 18-7.50x10			
353240	Rim W/Valvestem			
363311	Front Caster Complete			
363260	Front Tire & Tube 4.10-3.50-4			
Spindles				
583106	Spindle Asm Complete			
583111	Housing			
363350	Bearing			
583112	Shaft			
583113	Bearing Spacer Tube			
Transmission				
353228	RH 3100 Transaxle (Hydro-Gear Model #ZJ-GMEE-3LLB-1MLX)			
353229	LH 3100 Transaxle (Hydro-Gear Model #ZJ-KMEE-3LLC-1MLX)			
423361	Filter – 20W50 Motor Oil – Total System Capacity Approx 1.75 QT (1.66L)			
Throttle	593043			
Choke	593044			
Muffler	353193			
Wire Harness	353132			
Pigtail Harness	353180			
Clutch	423285			
Electrical Components				
423027	Ignition Switch			
422150	Starter Relay			
583423	Time Delay Module			
583351	Relay			
523034	Park Brake Switch			
593041	Neutral Switch			
523031	PTO Switch			
353048	Seat Switch Only			
5000016a	Seat Switch w/Mount			
523283	Hour Meter			

GENERAL INFORMATION

This manual covers the following equipment models: ED34FS600V
ED34FS600VCA

To the new owner

The purpose of this manual is to assist owners and operators in maintaining and operating the Encore Rider mower and deck. Please read it carefully; information and instructions furnished can help you achieve years of dependable service. A separate Engine Owner's Manual is included with your owner's packet which contains additional engine information that will not be repeated in this annual. You are urged to read it before attempting any operation or repair of the engine. **The Engine Owner's Manual covers the engine manufacturer's warranty.**

It is the owner's responsibility to make certain that the operator reads and understands this manual and all decals before operating this machine. It is also the owner's responsibility to make certain that the operator is a qualified and physically able individual, properly trained in the operation of this equipment. Local regulations may restrict the age of the operator.

Using this manual

General operation, adjustment and maintenance guidance is outlined for both the experienced and novice Encore user. Operating conditions vary considerably and cannot be addressed individually. Through experience, however, operators should find no difficulty in developing good operating skills suitable to most conditions. Directions used in this manual, for example RIGHT or LEFT, refer to directions when seated on the mower facing forward unless otherwise stated.

Photographs and illustrations used were current at the time of printing, but subsequent production changes may cause your machine to vary slightly in detail. Encore Mfg a division of Worldlawn Power Equipment, Inc. reserves the right to redesign and change the machine as deemed necessary, without notification.

Warranty Registration

The Delivery and Warranty Registration form must be completed and signed to validate your warranty protection. As the new equipment owner, you are expected to see that the form is completed and forwarded to Encore Mfg a division of Worldlawn Power Equipment Inc. at time of delivery.

IMPORTANT: Any unauthorized modification, alteration, or use of non-approved attachments voids the warranty and releases Encore Mfg a division of Worldlawn Power Equipment Inc. from any liability arising from subsequent use of this equipment.

Model and Serial Number

Mower model and serial number are found on the serial tag, located on the seat frame directly under the seat plate.

These numbers are required on the Warranty Registration form. They will also assure you of the correct service parts when replacement becomes necessary.

Parts and Service

Use original Encore replacement parts only. These parts are available through your local Encore dealer. To obtain prompt, efficient service, always provide the following information when ordering parts:

1. Correct part number and description
2. Correct model number
3. Correct serial number

All warranty repair and service must be handled through an authorized Encore dealer. Arrangements should be made through your local service center.

For location of nearest dealer look up our dealer search on our website:

www.encoreequipment.com

Your mower is only as safe as the operator! Operator carelessness or error may result in serious bodily injury. Improper maintenance of the machine may also result in injury. Please read and follow these instructions on Safe Operation and be certain that anyone using this mower fully understands and follows these instructions. Instructions are from ANSI Standard B71.4-2012

1. Familiarize yourself with the controls and know how to stop the rider and mower deck quickly.

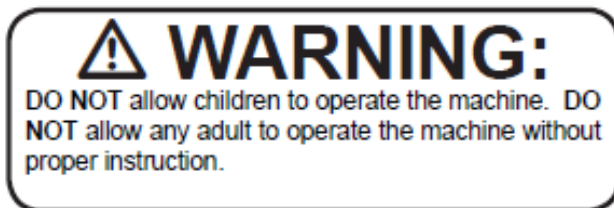

2. Inspect your work area carefully. Remove debris from the area to be cut. Keep all bystanders away from the mowing area.
3. **Avoid contact with moving parts. Keep hands and feet clear of the mower deck.**
4. Never direct the discharge of material toward bystanders or allow anyone near the machine while in operation.
5. The machine is not intended for high way or street use. Never carry passengers!
6. Never tamper with safety devices or guards. If a guard or safety device is damaged or removed, replace it before operating the rider.

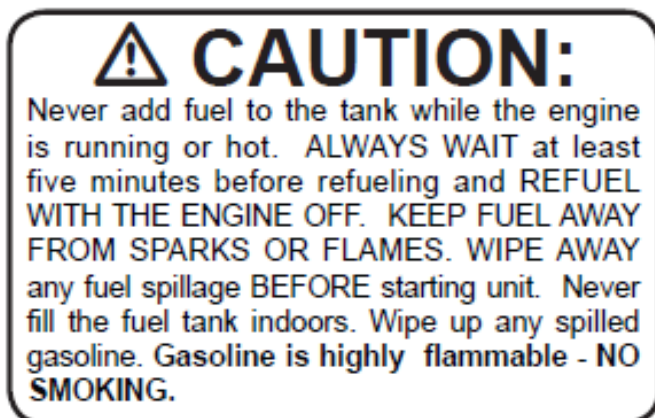

7. Handle gasoline carefully, Use an approved gasoline container. Fill the fuel tank, to within 1" from the neck, with good quality unleaded gasoline.
8. Seat must be occupied and drive levers must be in the Neutral position and the blade Clutch must be disengaged before starting engine.
9. Operator must wear proper shoes and clothing, which may include safety glasses and ear protection.
10. Mow only during daylight hours or under very good artificial light.
11. The safety shield over the Grass Discharge area must always be bolted in place and in the DOWN position unless the Grass Catcher is being used.
12. If a solid object has been hit by the blades stop the machine and check for damage. Repair or replace any damaged / broken part prior to restarting the engine.
13. To avoid burns, **DO NOT TOUCH** the engine or muffler immediately after operation or during.
14. Disengage blades when transporting and when crossing walks and gravel roads.
15. **DO NOT** mow close to drop-offs, deep ditches or other hazards. **DO NOT** attempt to mow slopes greater than 15°, Always mow across the face of a slope **NOT** up and down.
16. Reduce speed and exercise extreme caution on slopes and in sharp turns to prevent tipping or loss of control. Be especially cautious when changing direction on slopes.
17. The Encore Rider is **NOT** designed for towing.
18. **Only factory approved Grass Collection Systems are permitted.**
19. Shut off fuel while storing or transporting. Do Not store fuel near flames or drain indoors.

BEFORE OPERATING

Fill engine crankcase as per engine manufacturer's manual. **ENGINE DOES NOT HAVE OIL IN CRANKCASE FROM THE FACTORY.** Add proper fuel to fuel tank, open shut-off valve. The battery is a gel-cell and will not require acid. Before hooking up the ground wires, make sure that the engine has been filled to the proper level with oil. If battery will not turn the engine over after hooking the wires up it may require a charge for 15 to 20 minutes.

NOTES:

Consult engine manual for engine manufactures recommendation on operation, maintenance information and engine warranty information. Engine information will not be repeated in this manual.

ASSEMBLY INSTRUCTIONS

1. Remove unit from the crate.
2. Remove seat from packing. Remove the 5/16 x 3/4 bolts and disc spring washers from the seat plate. Attach seat to the seat plate using these same bolts and tighten.
3. Plug in the seat switch.
4. Connect the ground wire to the battery using the bolt on the negative battery post.
5. Remove the 5/16 x 1-1/4 bolts from the top side of the handle mounts. Rotate the handle to match up the holes, re-install the bolts and tighten.
6. Put oil in engine. See the engine Manual for type and quantity required.
7. Put fuel in fuel tank.
8. Check all tire pressures.
9. Read "Operator's Manual" before starting unit.

CAUTION:

Always remove the key and set the parking brake when leaving the machine unattended, even for just a few minutes.

PREVENT ACCIDENTS: Do not give children or unauthorized persons an opportunity to operate this machine.

STARTING ENGINE

The throttle c control, ignition switch and choke control are located between the motion control levers on the front panel under the front of the seat. Because of a built-in safety interlock system, your machine will not start unless the seat is occupied.

TO START ENGINE:

1. occupy seat,
2. set park brake,
3. leave the motion control levers swung out,
4. move throttle control lever all the way to choke position.
5. Turn ignition key to start position to engage starter
6. Release the key when engine starts.

Ignition switch is spring loaded and will return to run position automatically.

Slowly return choke to run position once the engine has started.

STOPPING ENGINE

TO STOP ENGINE:

Move throttle lever to idle position and turn ignition key to "off" position. If engine has been working hard or is hot, allow engine to idle for a short period of time before turning off key. This practice will help cool engine before stopping.

IN CASE OF EMERGENCY engine may be stopped by turning ignition key to "OFF" position.

DANGER

Observe usual fuel handling precautions:

Do not smoke while refueling.
Do not fill tank with engine running or while engine is hot.
Clean up any gasoline spills.
Allow engine to cool before storing machine inside a building.
Keep fuel away from open flame or spark and store mower away from open flame or spark if this fuel in the tank.
Use extra caution when handling gasoline and other fuels: They are flammable and vapors are explosive. A fire or explosion from gasoline or other fuels can burn you and others and can damage property.
Refuel outdoors preferably, or in well ventilated areas.
Never attempt to start engine when there is a strong odor of fuel fumes present. Locate and correct cause.
Store gasoline in an approved container and keep it out of the reach of children.
Never buy more than a 30 day supply of fuel.
Always place fuel containers on the ground away from your vehicle before fueling.
Do not fill gasoline containers inside a vehicle or a truck or a trailer as interior carpets or plastic truck bed liners may insulate the container and slow the loss of any static charge.
When practical, remove equipment from truck or trailer and refuel mower with its wheels on the ground.

SAFETY INTERLOCK SYSTEM

Your Encore Rider is equipped with a Safety Interlock System that is designed to help prevent possible serious injuries. Understanding and maintaining this system is vital, for maximum safe operation

To Start Engine

1. Blades (PTO) must be "OFF"
2. Control levers in neutral (swung out)
3. Park Brake "ON"
4. Operator in seat.

The Engine will kill if:

1. The operator leaves the seat with
 - a. The control levers out of neutral (swung in)
 - b. The blades on (PTO)
 - c. The park brake is "OFF"
 - d. All the above
2. The park brake is set before the control levers are in neutral (swung out):

CORRECT TRANSMISSION OPERATION

The Encore rider is equipped with a Hydro Transaxle unit for each wheel and are controlled with "Motion Control Levers", one for each wheel. See Figure 1

MOWING SPEED

The Encore rider is designed to operate most efficiently at maximum blade speeds.

The running speed of the machine should allow the mower blades to maintain this maximum speed while mowing across turf. Use a slower ground speed for cutting tall grass, grass which is heavy with moisture, or when mowing uphill. If ground speed is too fast, or blade speed is too slow, mowing will be uneven because mower blades will not be able to lift grass into cutting position as the mower passes.

Throttle control regulates speed of engine as measured in RPM. This control SHOULD NOT be used to control ground speed.

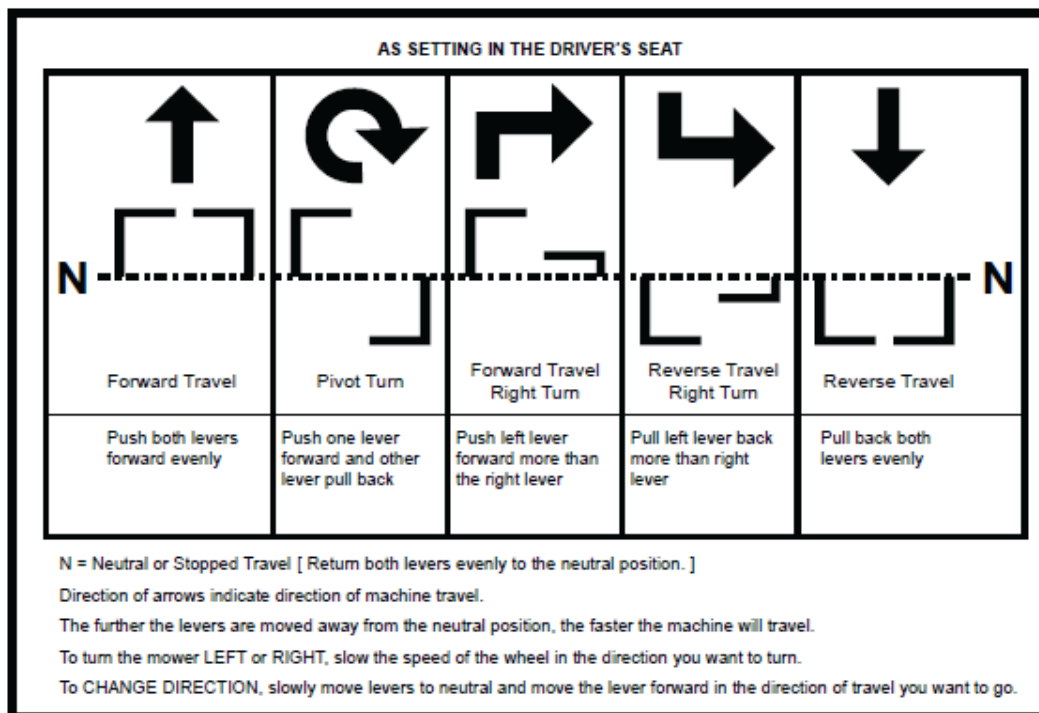

SERVICE LOCATOR CHART

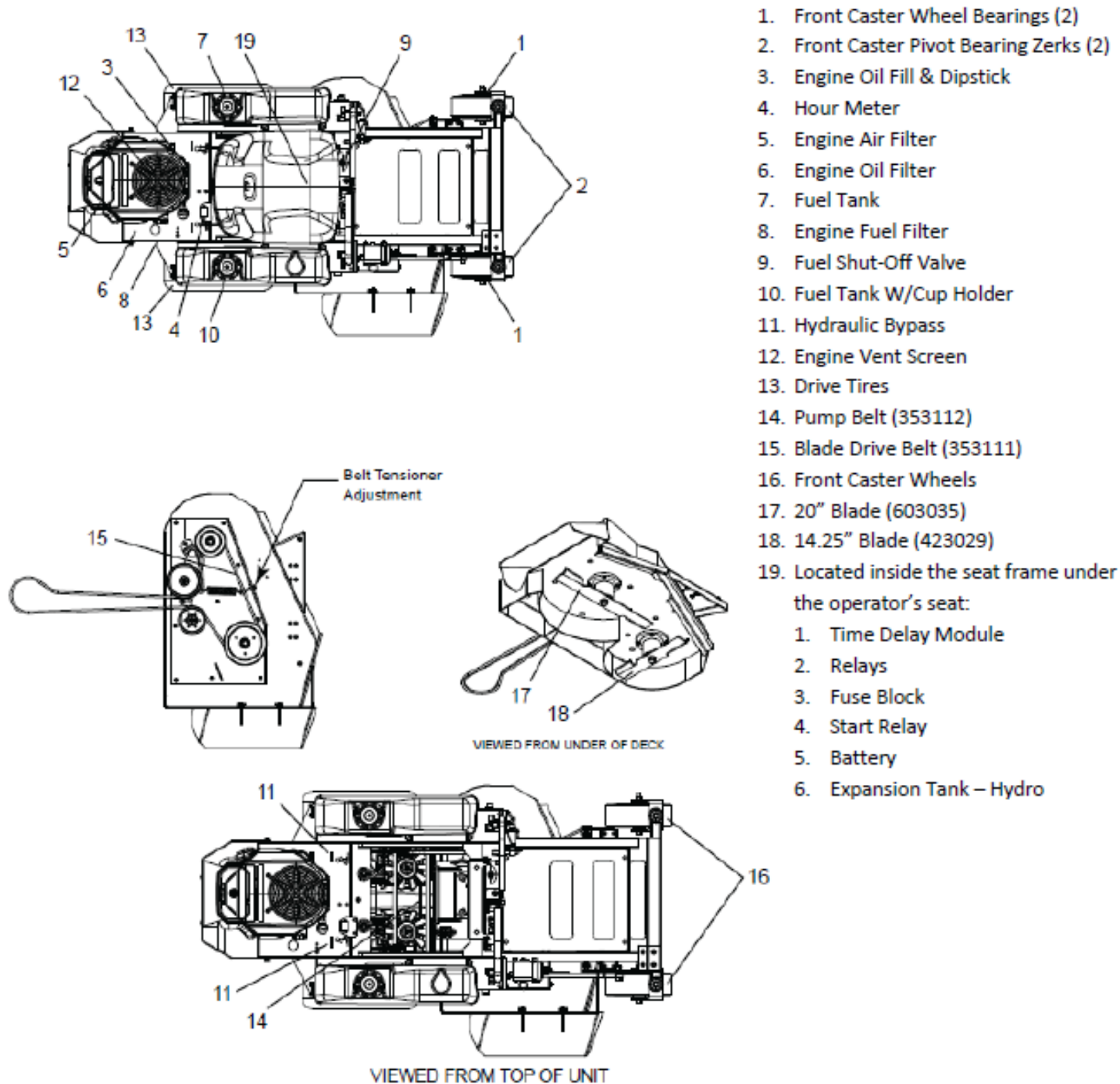

Figure 2

MAINTENANCE INFO

1. Do not adjust mower or change attachments unless the engine has been stopped and the key has been removed.
2. Good maintenance, wiping up gasoline and oil spills, will reduce potential fire hazards.
3. To insure that the mower will remain in safe operating condition, check and tighten all bolts, nuts and screws. Especially make certain the blade bolt/nuts are always tightened properly.
4. Never adjust governor on engine to a faster speed. The engine manufacturer adjust the engine RPM to the proper setting
5. Allow time for the engine to cool down prior to storing mower. Do not store mower or gasoline near any open flame or where gasoline fumes may be ignited.
6. Always replace worn or broken parts with genuine Encore repair parts purchased from an authorized Encore dealer. Using anything other than Encore repair parts may void all Encore factory warranties.

OIL AND FILTER

Please refer to the engine manual for engine lubrication recommendations. Transaxle is designed with an external filter and reservoir for ease of maintenance, To ensure constant fluid levels and longer life, an initial oil & filter change at 100 hours, then every 400 hours thereafter is recommended. Use 20w50 engine oil. It uses approximately 56 fl. oz.



TIRE PRESSURE

This vehicle has been designed to achieve maximum operator comfort and ride. This cannot be achieved without proper tire pressure. A low pressure gauge is required to check the front tires.

Front Tires – 14 PSI

Rear Tires – 18 PSI

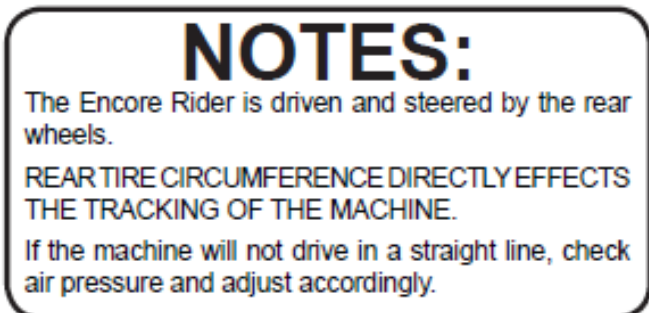

LUBRICATION

The following recommendations on lubrication chart below should be adhered to. Environmental conditions may be cause to vary frequency. Grease points are pointed out in Figure 2.

Description of Maintenance Task	Service Intervals
Blades - sharpen & securely fastened to 65 ft-lbs	Every 10 hours
Check fuel level	Daily
Discharge chute - securely in place & in lowest position	Daily
Verify safety start interlock system	Daily
Visually inspect tires	Daily
Visually inspect unit for loose hardware and/or damaged parts	Daily
Check battery connections	Every 50 hours
Check tire pressure with a gauge	Every 50 hours
Check pump drive belt tension & condition	Every 100 hours
Check blade drive belt tension & condition	Every 100 hours
Check deck drive belt tension & condition	Every 100 hours
Tighten lug nuts on wheels	Every 100 hours
Check oil level in engine	See Note A
Change engine oil & filter	See Note A
Change fuel filter	See Note A
Clean air intake screen	See Note A
Clean cylinder / head fins	See Note A
Clean foam element	See Note A
Clean paper element	See Note A
Replace air cleaner paper element	See Note A
Clean and regap or replace spark plugs	See Note A

Note:

- A. Refer to Supplied Engine Manufacturers Owner's Manual for all maintenance and engine manufactures warranty policy information

BATTERY

The battery is located under the seat of the machine. The gel-cell battery is maintenance free.

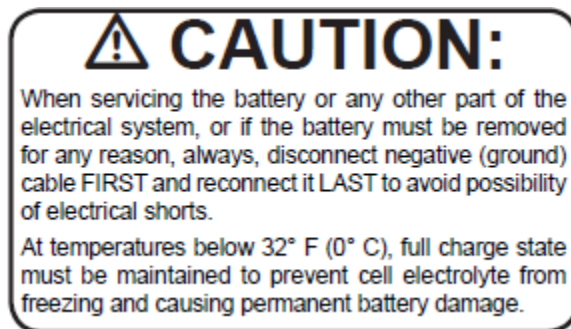

For longest service life, battery should be kept clean by wiping it off with a paper towel. Any corrosion around battery should be removed by applying a solution of one part baking soda to four parts water. A light coating of grease or petroleum jelly may be applied to all exposed terminal surfaces to prevent corrosion.

BELT ADJUSTMENT

Remove key from the ignition switch. The blade drive belt may be accessed by removing belt shields. Spring tension should be maintained by having

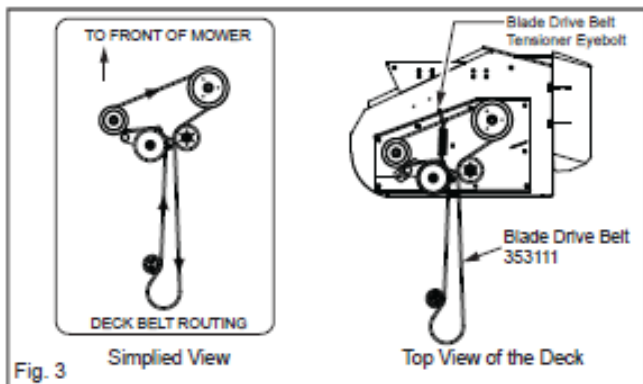

Approximately 1/8" stretch between coils. Turning the nut on the eyebolt clockwise will decrease tension. When installing a blade drive belt please refer to figure 3 for routing the blade drive belt. The pump belt

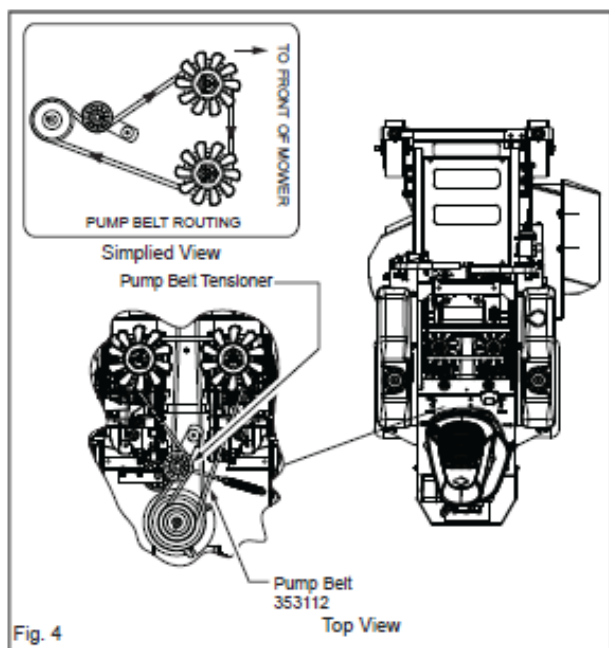

may be accessed from under the rear chassis. The pump belt is removed by unhooking the tensioner spring to provide slack in the belt for removal. When installing a pump belt please refer to figure 4 for the routing of the pump belt.

BYPASS VALVE

In some applications, it is desirable to move the machine for short distances at low speeds without operating engine. See fig. 6

DECK HEIGHT ADJUSTMENT

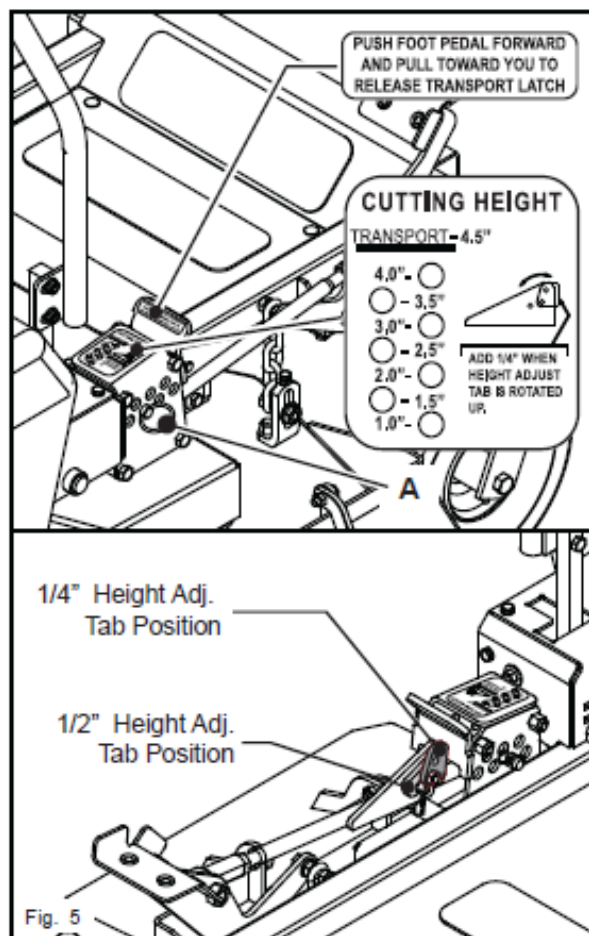

Height of cut positions are drilled at 1/2 inch increments. To add 1/4 inch to the setting you must first remove the #4 hairpin cotter, pull pin and rotate the tab to the vertical position. The foot pedal must be depressed slightly in order to replace the pin in tab. See Fig. 5

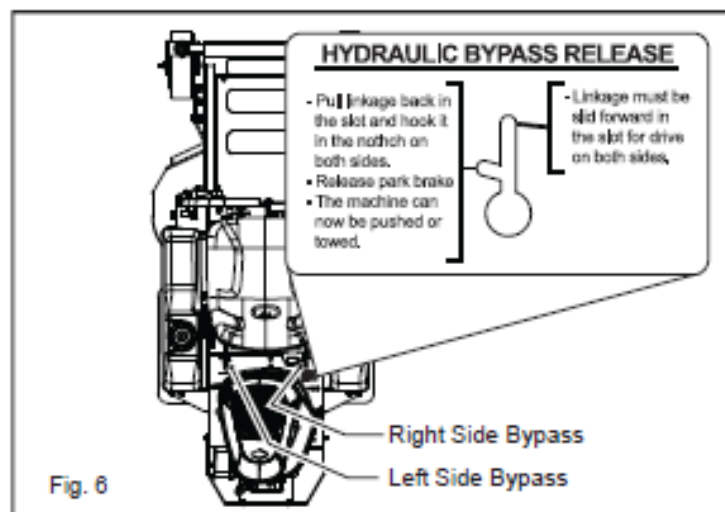

DECK LEVELING ADJUSTMENT

Before checking the deck level make sure that tire pressures are at the proper level. Begin by setting the deck to a fixed position and pointing the blades to the front edge of the deck.

Measuring from the blade to the ground on each side of the deck will give the best reading. To adjust deck position loosen the bolt on the deck hanger bracket and move bolt in the slot either up or down depending which way you need to move the deck. You should

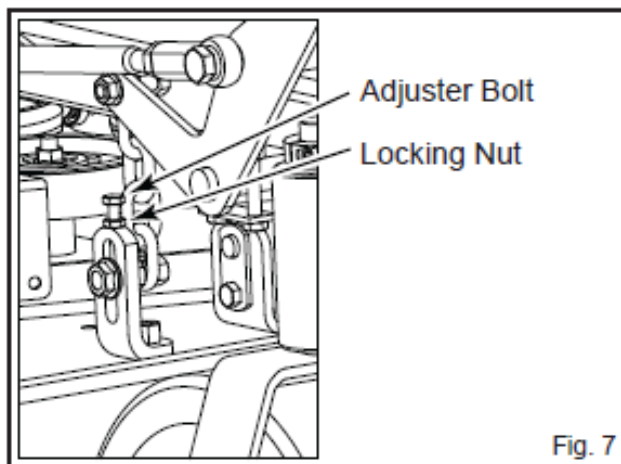

Always maintain at least a 1/7 inch of deck pitch from front to back. Also all four chains must support the deck equally or must have equal tension on them.

TRACKING ADJUSTMENT

Before adjusting the tracking you must be sure that the tire pressures are equal. If the machine will not track straight on a flat surface it may be adjusted by moving the stop bolt (located by either control arm) clockwise to increase ground speed and counter clockwise to decrease ground speed.. Normally only one side is adjusted to match the ground seed of the other pump/

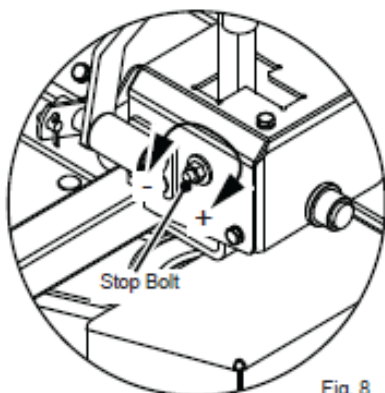

MOWER BLADES

Check sharpness of mower blades after every 10 hours or operation. To sharpen blades proceed as follows:

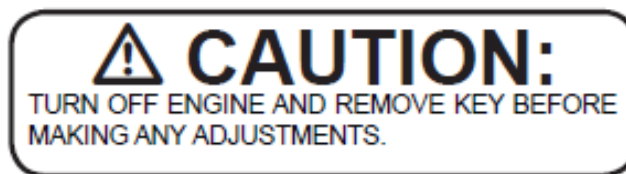

- ◆ Block front end of mower up or run front up on ramps.
- ◆ Remove blade by turning bolt counter clockwise.
- ◆ Blades should be discarded when worn excessively. See Sketch



- ◆ Sharpen blade with a hand file, electric grinder or blade sharpener. Wear gloves and eye protection when sharpening. Grind blade at original bevel.
- ◆ Check balance of blade by positioning the blade on a nail or blade balance pedestal. Grind the blade on the end that is heavier until both sides balance.
- ◆ Do not wear loose fitting clothing which could get caught in moving parts. Always be sure to wear adequate protective clothing. Wearing safety glasses and safety shoes is advisable.
- ◆ Reinstall blades. Refer to Figure 9 for further information.

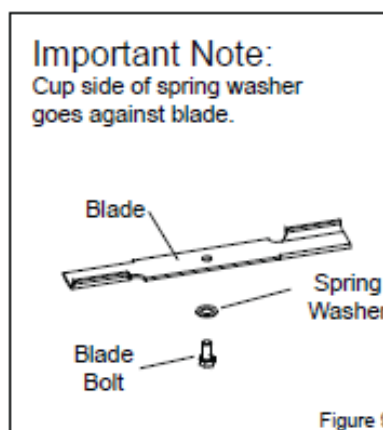

WIRING SCHEMATIC

Encore part #353132
Wire Harness for ED34FS600V

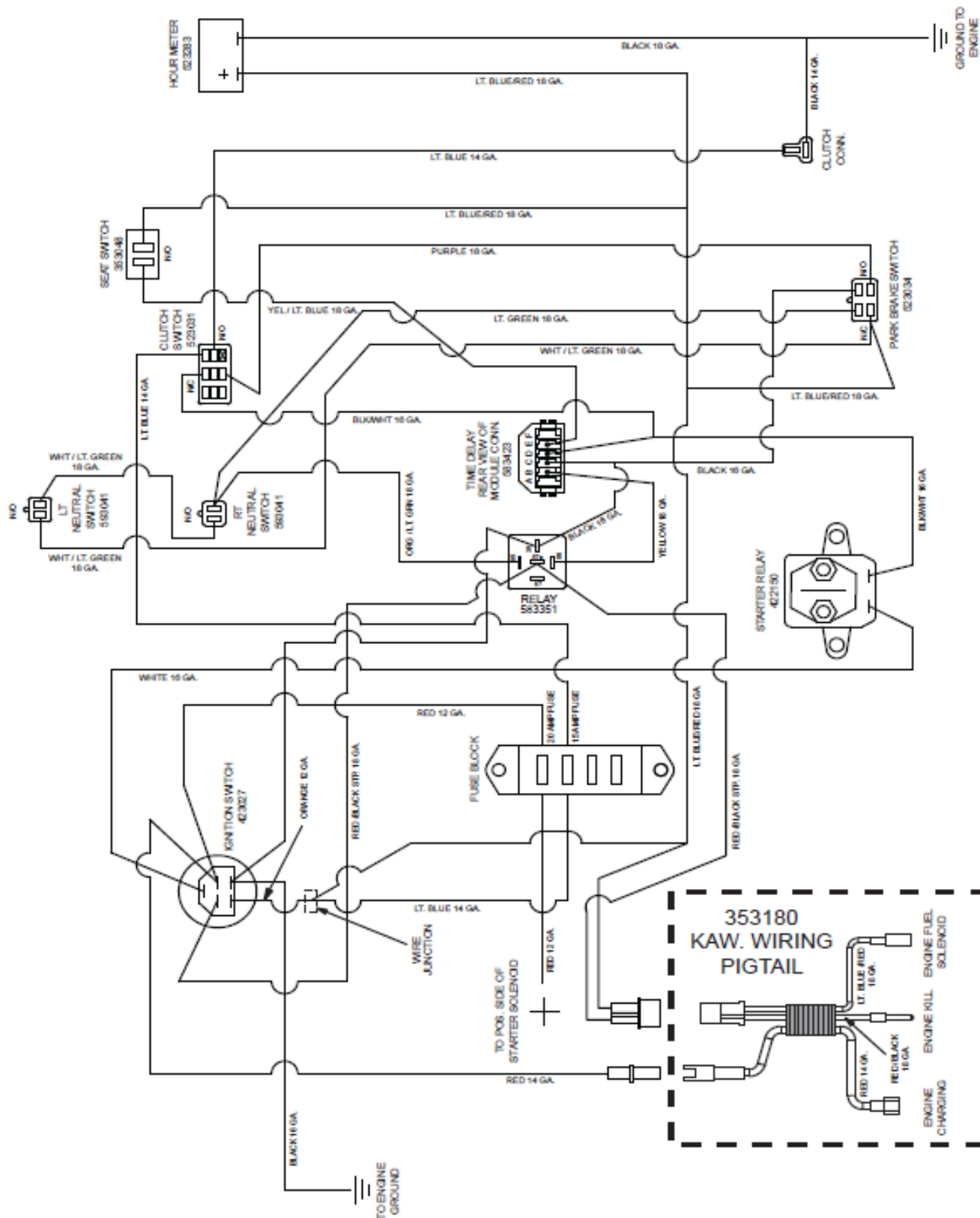

CALIFORNIA EVAPORATIVE EMISSION CONTROL WARRANTY STATEMENT

YOUR WARRANTY RIGHTS AND OBLIGATIONS

The California Air Resources Board and Worldlawn Power Equipment is pleased to explain the evaporative emission control system's warranty on your 2014 model year lawn mower. In California, new equipment that use small off-road engines must be designed, built, and equipped to meet the State's stringent anti-smog standards. Worldlawn Power Equipment must warrant the evaporative emission control system on your lawn mower for the period listed below provided there has been no abuse, neglect or improper maintenance of your equipment.

Your evaporative emission control system may include parts such as: fuel tanks, fuel lines, fuel caps, valves, canisters, vapor hoses, clamps, connectors, and other associated components. **For engines less than or equal to 80 cc, only the fuel tank is subject to the evaporative emission control warranty requirements of this section.**

MANUFACTURER'S WARRANTY COVERAGE:

This evaporative emission control system is warranted for two years. If any evaporative emission-related part on your equipment is defective, the part will be repaired or replaced by Worldlawn Power Equipment.

OWNER'S WARRANTY RESPONSIBILITIES:

- As the lawn mower owner, you are responsible for performance of the required maintenance listed in your owner's manual. Worldlawn Power Equipment recommends that you retain all receipts covering maintenance on your lawn mower, but Worldlawn Power Equipment cannot deny warranty solely for the lack of receipts.
- As the lawn mower owner, you should however be aware that Worldlawn Power Equipment may deny you warranty coverage if your fuel tank has failed due to abuse, neglect, or improper maintenance or unapproved modifications.
- You are responsible for presenting your lawn mower to a Worldlawn Power Equipment distribution center or service center as soon as the problem exists. The warranty repairs should be completed in a reasonable amount of time, not to exceed 30 days. If you have a question regarding your warranty coverage, you should contact Worldlawn Power Equipment service at (402) 228-4255.

DEFECTS WARRANTY REQUIREMENTS:

(a) The warranty period begins on the date the engine or equipment is delivered to an ultimate purchaser.

(b) General Evaporative Emissions Warranty Coverage. The fuel tank must be warranted to the ultimate purchaser and any subsequent owner that the evaporative emission control system when installed was:

(1) Designed, built, and equipped so as to conform with all applicable regulations; and

(2) Free from defects in materials and workmanship that causes the failure of a warranted part for a period of two years.

(c) The warranty on evaporative emissions-related parts will be interpreted as follows:

(1) Any warranted part that is not scheduled for replacement as required maintenance in the written instructions must be warranted for the warranty period defined in subsection (b)-(2). If any such part fails during the period of warranty coverage, it must be repaired or replaced by Worldlawn Power Equipment. Any such part repaired or replaced under the warranty must be warranted for a time not less than the remaining warranty period.

(2) Any warranted part that is scheduled only for regular inspection in the written instructions must be warranted for the warranty period defined in subsection (b)-(2). A statement in such written instructions to the effect of "repair or replace as necessary" will, not reduce the period of warranty coverage. Any such part repaired or replaced under warranty must be warranted for a time not less than the remaining warranty period.

(3) Any warranted part that is scheduled for replacement as required maintenance in the written instructions must be warranted for the period of time prior to the first scheduled replacement point for that part. If the part fails prior to the first scheduled replacement, the part must be repaired or replaced by Worldlawn Power Equipment. Any such part repaired or replaced under warranty must be warranted for a time not less than the remainder of the period prior to the first scheduled replacement point for the part.

(4) Repair or replacement of any warranted part under the warranty provisions of this article' must be performed at no charge to the owner at a warranty station.

(5) Notwithstanding the provisions of subsection (4) above, warranty services or repairs must be provided at distribution centers that are franchised to service the subject engines or equipment.

(6) The owner must not be charged for diagnostic labor that leads to the determination that a warranted part is in fact defective, provided that such diagnostic work is performed at a warranty station.

(7) Throughout the evaporative emission control system's warranty period set out in subsection (b)(2), Worldlawn Power Equipment must maintain a supply of warranted parts sufficient to meet the expected demand for such parts.

(8) Manufacturer approved replacement parts must be used in the performance of any warranty maintenance or repairs and must be provided without charge to the owner. Such use will not reduce the warranty obligations of the manufacturer issuing the warranty.

(9) The use of any add-on or modified parts will be grounds for disallowing a warranty claim made in accordance with this article. Worldlawn Power Equipment will not be liable under this Article to warrant failures of warranted parts caused by the use of an add-on or modified part.

(10) Worldlawn Power Equipment shall provide any documents that describe the warranty procedures or policies within five working days of request by the Air Resources Board.

EMISSION WARRANTY PARTS LIST:

1) Fuel Tank, 2) Fuel line, 3) Fuel cap, 4) remote vent, 5) Carbon canister

Written instructions for the maintenance and use of the evaporative emissions control system by the owner shall be furnished with each new engine or equipment

ENCORE LIMITED WARRANTY

Worldlawn Power Equipment, Inc, (“Worldlawn”) warrants that the Worldlawn DART mower (“Mower”), purchased from an Authorized Worldlawn Dealer, will be free from defects in material and workmanship for a period of three years commercial/residential from the original date of purchase (see details below). Worldlawn also warrants the Mower’s deck shell will be free from defects in material and workmanship for a period of ten years commercial/residential from the original date of purchase (see details below). During the limited warranty period, Worldlawn will repair or replace, at its discretion, any Mower or part thereof which is found to be defective in material and workmanship. This limited warranty specifically excludes wear items, included but not limited to belts, blades, and tires. This limited warranty also specifically excludes parts covered by another manufacturer’s warranty, in which parts are covered only by that manufacturer’s warranty. **This limited warranty does not extend to the engine or the hydro’s which are warranted separately by the engine manufacturer and hydro manufacturer**

This limited warranty extends only to the original retail purchaser (“Owner”) of a Mower. This limited warranty may not be assigned or transferred without prior express written consent of Worldlawn Power Equipment, Inc. This limited warranty extends only to those Mowers purchased for private residential and commercial use. A Mower purchased for any other reason, for example as a rental unit, shall have a (90) day limited warranty under the same terms and conditions as set forth herein.

Proof of purchase will be required to substantiate all warranty claims. All warranty work must be performed by an Authorized Worldlawn Dealer. Any work done on or to the Mower by anyone other than an Authorized Worldlawn Dealer, including the original purchaser, voids all provisions of the warranty except those provisions which limit Worldlawn’s liability (as set forth below).

Any Mower or part thereof which, in Worldlawn’s sole discretion, is deemed defective shall be repaired or replaced, at Worldlawn’s option, without charge for parts or labor up to three years of the original date of purchase. Any Mower deck shell, in Worldlawn’s sole discretion, is deemed defective shall be repaired or replaced, at Worldlawn’s option, without charge for parts or labor for the first five years of the original date of purchase, and without charge for parts only for years six through ten from the original date of purchase. To take advantage of this limited warranty, the Mower must be returned to an Authorized Worldlawn Dealer within the warranty period. **The cost of delivering the Mower to the Authorized Dealer and return delivery shall be the responsibility of the Owner.**

Worldlawn’s sole responsibility with any claim made under this warranty is limited only to repairing or replacing the Mower or a defective part thereof, and no claim of breach of warranty shall be cause for rescission, cancellation, or voiding the contract of sale of the Mower.

This limited warranty does not extend to any Mower or part thereof which has been misused, neglected, damaged, abused, not properly installed or maintained, altered or which has been operated in any way contrary to the operating instructions as specified in the Owner/Operator Manual. This limited warranty does not extend to any repair or replacement made necessary by normal use.

THE WARRANTY EXPRESSED HEREIN IS IN LIEU OF OTHER WARRANTIES, EXPRESSED OR IMPLIED, INCLUDING, WITHOUT LIMITATION, ANY IMPLIED WARRANTY OR MERCHANTABILITY OR FITNESS FOR A PARTICULAR USE, AND IS IN LIEU OF ANY AND ALL OTHER OBLIGATIONS OR LIABILITY ON WORL DLAWN’S PART.

UNDER ANY AND ALL CIRCUMSTANCES, WORL DLAWN’S TOTAL LIABILITY TO OWNER FOR ANY AND ALL CLAIMS, LOSSES OR DAMAGES, INCLUDING LOSS OF PROFITS, ARISING OUT OF ANY CAUSE WHATSOEVER, WHETHER BASED IN CONTRACT, NEGLIGENCE OR OTHER TORT, STRICT LIABILITY, BREACH OF WARRANTY OR OTHERWISE, SHALL IN NO EVENT EXCEED THE PURCHASE PRICE OF THE MOWER. IN NO EVENT SHALL WORL DLAWN BE RESPONSIBLE FOR SPECIAL, INCIDENTAL, CONSEQUENTIAL OR EXEMPLARY DAMAGES.



ENCORE

ALL RIGHT RESERVED

CONTENTS SUBJECT TO CHANGE

ED34FS600V PARTS MANUAL

DART

20131210