



ENCORE

MANUFACTURING CO. INC.

PRO-Line RIDER

52K550R

**OPERATORS
MANUAL**





ENCORE PRO-Line RIDER

This manual contains instructions for your Encore Rider. You should be trained in the proper use and warned of the dangers before operating, adjusting, or servicing the Encore Rider. You should also read and understand this entire manual.

CONTENTS

Section.....	Page
General Safety Instructions.....	2
Assembly Instructions.....	2
Before Operating - Reminders.....	3
Starting Engine.....	3
Stopping Engine.....	3
Safety Interlock System.....	3
Transmission Operation - Forward or Reverse.....	3
Mowing Speed.....	4
Maintenance/Service	
Oil and Filter.....	4
Tire Pressure.....	4
Battery.....	4
Lubrication.....	5
Drive Adjustments.....	5
Clutch Evaluation.....	6
Burnishing Clutch/Brakes.....	7
Airgapping Clutch/Brakes.....	7
Belt Adjustment.....	8
Deck Height Adjustment.....	9
Blades.....	9
Charging System.....	9
Electrical.....	10
Hydrostatic Transaxle Repair.....	11
Warranty.....	18

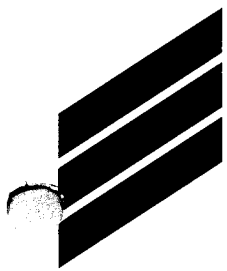

ENCORE PRO-Line RIDER

General Safety Instructions

YOUR MOWER IS ONLY AS SAFE AS THE OPERATOR! Operator carelessness or error may result in serious bodily injury. Improper maintenance of the machine may also result in injury. Please read and follow these instructions on safe operation and be certain that anyone using this mower fully understands and follows these instructions.

1. Familiarize yourself with the controls and know how to stop the Rider and mower deck quickly.
2. Do not allow children to operate this machine. Do not allow adults to operate the machine without proper instruction.
3. Inspect your work area carefully. Remove debris from the area to be cut. Keep all bystanders away from the mowing area.
4. Avoid contact with moving parts. Keep hands and feet clear of the mower deck.
5. Never direct the discharge of material toward bystanders nor allow anyone near the machine while in operation.
6. This machine is not intended for highway or street use. Never carry passengers.
7. Never tamper with safety devices or guards. If a guard or safety device is damaged or removed, replace it before operating the Rider.
8. Handle gasoline carefully: use an approved gasoline container; fill the fuel tank to within 1" from the neck with good quality leaded or unleaded gasoline; never add fuel to the tank while the engine is running or hot; never fill the fuel tank indoors; wipe up spilled gasoline. Gasoline is highly flammable - **NO SMOKING**.
9. Drive levers must be in the neutral position and blade clutch must be disengaged before starting the engine.
10. Operator must wear proper shoes and clothing, which may also include safety glasses.
11. Mow only during daylight hours or under very good artificial light.
12. The safety shield over the grass discharge area must always be bolted in place and in the down position unless the grass catcher is being used.
13. If a solid object has been hit by the blades, stop the machine and check for damage. Repair or replace any damaged/broken part prior to restarting the engine.

14. To avoid burns, DO NOT TOUCH the engine or muffler immediately after operation.
15. Disengage blades when transporting and when crossing walks and gravel roads.
16. Do not mow close to drop-offs, deep ditches or other hazards. Do not stop or start suddenly when going uphill or downhill. Mow up and down the face of steep slopes; never mow across the face. If a steep hill must be ascended, **BACK** up the hill; drive forward when descending.
17. Reduce speed and exercise extreme caution on slopes and in sharp turns to prevent tipping or loss of control. Be especially cautious when changing directions on slopes.
18. DO NOT tow loads up hills or loads that are too heavy for the machine as it could make the front of the mower flip up.
19. When towing a heavy load, push levelers forward slowly, quick starts may make the mower's front end hop.

Assembly Instructions

Remove unit from crate, taking care to remove inner boxes and the small parts box.

1. Remove deflector chute, bolt bag and operator's manual from main assembly.
2. Open bolt bag and lay out bolts:
 - (8) $\frac{5}{16} \times \frac{3}{4}$ HHCS
 - (2) $\frac{5}{16} \times 1$ HHCS
 - (2) $\frac{5}{16}$ nyloc nuts
 - (4) $\frac{5}{16}$ whiz nuts
 - (4) $\frac{5}{16}$ lock washers
3. Take the two $\frac{5}{16} \times 1$ and two nyloc nuts and bolt deflector into place.
4. Take the four $\frac{5}{16} \times \frac{3}{4}$ with four lock washers and fasten seat to the seat plate.
5. Take the remaining bolts and whiz locks and bolt control levers onto the outsides of the mount angles, adjusting them according to operator comfort.
6. Attach the wire harness to the seat switch.
7. Be sure to put coolant in radiator and oil in engine before starting.



ENCORE PRO-Line RIDER

Before Operating – Reminders

Fill engine crankcase and radiator as per engine manufacturer's manual. Engine **DOES NOT** have oil in crankcase from the factory. Engine also **DOES NOT** have coolant in radiator from the factory. Add proper fuel to fuel tank, open valve by fuel pump. The battery is a **dry battery** and must be filled with the proper electrolyte.

Once you are familiar with the contents of this manual you are ready to mow with the finest mower built!

Starting Engine

Throttle control, ignition switch and choke control are located between motion control levers on the front panel under the front of the seat.

Because of a built-in safety interlock system, your machine will not start unless the seat is occupied.

TO START ENGINE: occupy seat, move throttle control lever halfway to operating position, pull choke control all the way out to cold position. Turn ignition key to start position to engage starter, release the key when the engine starts. Ignition switch is spring loaded and will return to run position automatically.

Slowly return choke to run position once the engine has started.

Stopping Engine

TO STOP ENGINE: move throttle lever to idle position and turn ignition key to off position. If engine has been working hard or is hot, allow engine to idle for a short period of time before turning off key. This practice will help cool engine before stopping.

IN CASE OF EMERGENCY engine may be stopped by turning ignition key to off position.



CAUTION



Always remove key and set parking brake when leaving machine unattended, even for just a few minutes. PREVENT ACCIDENTS: do not give children or unauthorized persons an opportunity to operate this machine.

Safety Interlock System

Every Encore Rider has interlock switches. Switches are activated by the seat. The seat switch will stop engine when the seat is vacated with engine running.

The seat must be occupied for the engine to start.

If your machine will not start, check if the drive levers are in the neutral position and that the seat is occupied.

The safety interlock system must be tested periodically. The following functions must be observed to test operation. If there is a malfunction, immediate repairs must be performed by an authorized Encore dealer for your protection.

1. Engine should not start if seat is not occupied.
2. With engine running, test the seat switch by rising off the seat. Engine should shut off.
3. Engage park brake and move drive levers from the neutral position. Engine should shut off. Engine should also kill if park brake is engaged while machine is moving.

Correct Transmission Operation to Go Forward or Reverse

The Encore Rider is equipped with a separate transmission for each wheel. Transmissions are controlled with "Motion Control Levers," one for each wheel.

- To go forward, push both levers forward evenly.
- To go in reverse, pull back on both levers evenly.
- To change direction, slowly move levers to neutral and move the lever forward in the direction you want to go.
- The further the levers are moved away from the neutral position, the faster the machine will travel. To turn the Rider left or right, slow the speed of the wheel in the direction you want to turn.
- To stop the Rider, return both levers evenly to the neutral position.



ENCORE PRO-Line RIDER

Mowing Speed

The Encore Rider is designed to operate most efficiently at maximum blade speeds. The running speed of the machine should allow the mower blades to maintain this maximum speed while mowing across turf. Use a slower ground speed for cutting tall grass, grass which is heavy with moisture, or when mowing uphill. If ground speed is too fast, or blade speed is too slow, mowing will be uneven because mower blades will not be able to lift grass into cutting position as mower passes.

Throttle control regulates speed of engine as measured in RPM. This control **SHOULD NOT** be used to control ground speed.

Maintenance and Service

1. Do not adjust mower or change attachments unless engine has been stopped and key has been removed.
2. Good maintenance, wiping up gasoline and oil spills, will reduce potential fire hazards.
3. To insure that the mower will remain in safe operating condition, check and tighten all bolts, nuts and screws. Especially make certain the blade bolt/nuts are always tightened properly.
4. Never adjust governor on engine to a faster speed. Engine RPM is adjusted to the proper setting at by the engine manufacturer.
5. Allow time for engine to cool down prior to storing mower. Do not store mower or gasoline near any open flame or where gasoline fumes may be ignited.
6. Always replace worn or broken parts with genuine Encore repair parts purchased from an authorized Encore dealer. Using anything other than Encore repairs parts may void all Encore factory warranties.



CAUTION



Do not spill oil or grease on belts.

Oil and Filter

Change transmission 10-micron filters between 50-100 hours the first time, every 500 hours thereafter.

Also change standard engine oil filter as recommended by engine manufacture in engine manual.

Change 20W-50 API.CD rated oil in the hydrostatic system every 500 hours by pulling the plug in the bottom of reservoir tank. Change the transmission 10-micron filter at the same time.

Tire Pressure

This vehicle has been designed to achieve maximum operator comfort and ride. This cannot be achieved without proper tire pressure. A low pressure gauge is required to check the front tires.

FRONT TIRE: 14 psi

REAR TIRE: 20 psi

NOTE: The Encore Rider is driven and steered by the rear wheels. **REAR TIRE CIRCUMFERENCE DIRECTLY EFFECTS THE STEERING OF THE MACHINE.** If the machine will not drive in a straight line, check air pressure and adjust accordingly.

Battery



CAUTION

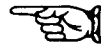

When servicing battery or any other part of electrical system, or if battery must be removed for any reason, always disconnect negative (ground) cable FIRST and reconnect it LAST to avoid possibility of electrical shorts.

At temperatures below 32°F (0°C), full charge state must be maintained to prevent cell electrolyte from freezing and causing permanent battery damage.

Maintain electrolyte level above plates in each cell by adding distilled water as necessary. The best time to add water is just prior to operating the mower so water will mix with the solution. Do not over fill battery: *electrolyte solution is corrosive and over filling can cause damage to surrounding metal parts.* Battery should be maintained at 1.265 gravity charge. When replacing battery after servicing, take care to reconnect cables exactly the way they were before removing the battery.

For longest service life, battery should be kept clean by wiping it off with a paper towel. Any corrosion around battery should be removed by applying a solution of one part baking soda to four parts water. A light coating of grease or petroleum jelly may be applied to all exposed terminal surfaces to prevent corrosion.



ENCORE PRO-Line RIDER



CAUTION



Batteries produce flammable hydrogen gas. Avoid creating sparks and open flames and do not smoke when working near batteries.

Battery electrolyte solution is poisonous and can be injurious to eyes, skin and clothing.

IN THE EVENT OF AN ACCIDENT: Flush affected area immediately with a solution of one part baking soda to four parts water. If baking soda is not readily available flush affected area with water. Notify physician immediately.



CAUTION



Turn off engine before making adjustments.

Lubrication

The following recommendations on lubrication should be adhered to. Environmental conditions may be cause to vary frequency.

Before each use:

- clean engine chaff screen
- check engine oil and tires

Every 100 hours:

- lubricate chassis
- lubricate front wheels
- lubricate drive and pump control pivot points
- lubricate casters on deck
- check belt tension

Every 200 hours:

- lubricate cutter housings (1 to 2 pumps)



CAUTION



DO NOT over grease housings - it will push seals out of bearings.

Drive Adjustments

Steering and motion controls should be uniform in all forward and reverse speeds. Levers should automatically return to neutral when released.

To test drive operations:

- Check air pressure in tires. Equal tire pressure is critical for proper drive operation.
- Check linkage for excessive play.
 - Raise rear of Rider until rear wheels are off the ground. Safely block the frame in this position.
 - Put control levers in neutral lock position (control levers swung outward).
 - Start engine.

Wheels should not rotate. If one or both rear wheels are turning, perform procedures under "Neutral Adjustments" for side(s) that wheels turn. (figure 1)

Figure 1

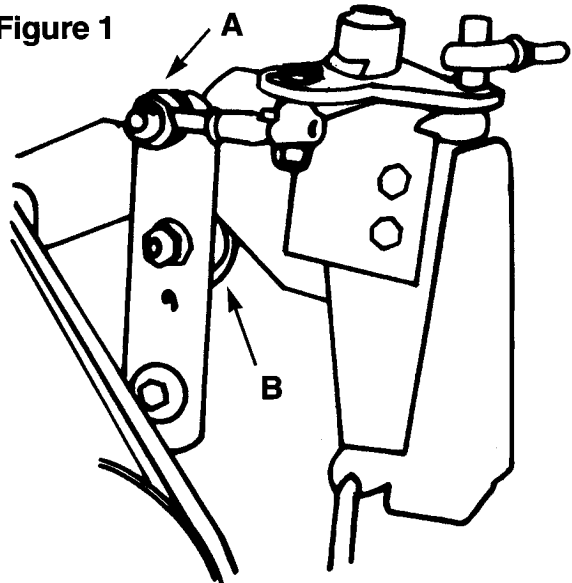

Neutral Adjustments:

With rear wheels raised (see figure 1), remove control link from pump arm (A). Loosen neutral bearing on pump arm (B) and adjust until wheel stops, then retighten bearing and adjust control link (A) accordingly. Make sure that control arm stays locked in neutral.



ENCORE PRO-Line RIDER

Instructions for Evaluating VX and Series Clutches 5210/5215

NOTE: All values taken at room temperature. Voltage at 12 VDC. As temperature increases, resistance increases and current decreases.

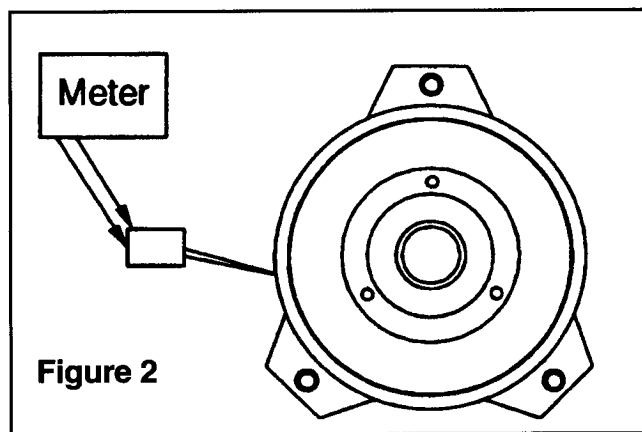

Figure 2

STEP 1. MEASURE CLUTCH COIL RESISTANCE

1. Turn engine and PTO switch off.
2. Disconnect clutch wire connection.
3. Select meter to check ohms.
4. Connect meter lead wires to the wires in the clutch connector (see figure 2).
5. If meter reads below 2.40 ohms or above 2.90 ohms, the clutch has failed and needs to be replaced. If meter reads between 2.40 and 2.90 ohms, proceed to STEP 2.

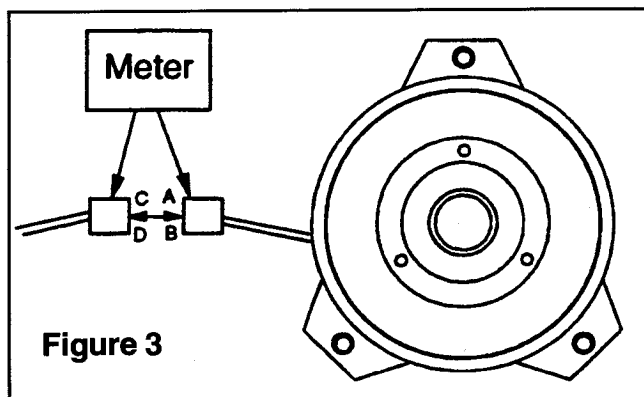

Figure 3

STEP 2: MEASURE CLUTCH CURRENT DRAW-12 VOLT SYSTEM.

1. Turn off engine.
2. Disconnect clutch wire connection.
3. Select meter to check amps (10 amp scale).
4. Connect one meter lead wire to one wire in clutch connector at A (see figure 3).
5. Connect the other meter lead wire to the corresponding wire in the mating connector at C (see figure 3).
6. Connect a short wire from D to B in both connectors (see figure 3).
7. Turn PTO switch on.
8. If meter reads below 4.0 amps, the problem is in the electrical system leading to the clutch (battery, relay, switch, etc.). If meter reads 4.0 amps or above, proceed to STEP 3.

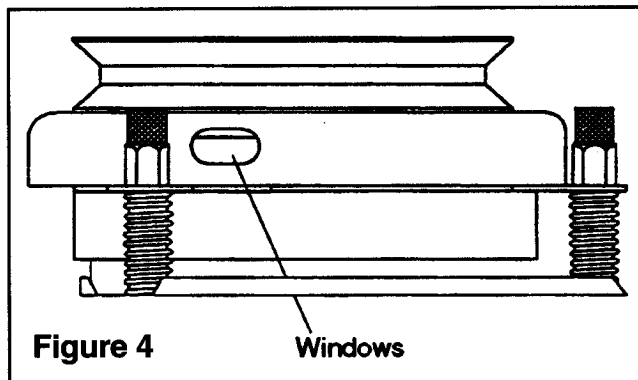

Figure 4

Windows

STEP 3. CHECK AIRGAP SETTING

1. Turn engine and PTO switch off.
2. Locate the three "windows" or "notches" where the airgap is checked (see figure 4).
3. With feeler gauge, check airgap at all three locations (minimum of two).
4. Factory airgap setting is .005"-.023".
5. If gap doesn't fall between .005"-.023" then reset using .012" feeler gauge.

If you find after completing steps 1, 2 and 3 . . .

- The resistance falls between 2.40-2.90
- The amp draw is 4.0 or above
- The airgap is between .005" and .023" or reset to .012"

. . . then the electric clutch is within factory specifications and is not the source of the problem.



ENCORE PRO-Line RIDER

Burnishing Procedure for Electric Clutch/Brakes

To be performed with mower deck attached.

1. Run at 50% throttle.
2. Engage and disengage the clutch 5 times. (10 seconds on/10 seconds off)
3. Increase to 75% throttle.
4. Engage and disengage the clutch 5 times (10 seconds on /10 seconds off)

Procedure for Airgapping Bearing Mounted PTO Clutch/Brakes

Airgaps are preset at the factory and **DO NOT** require initial adjustment.

Bench setting:

1. Remove clutch from tractor.
2. Orient the clutch so it is viewed from the field side.
3. Locate the three rivet joints in the armature assembly which fasten the leaf springs to the armature.

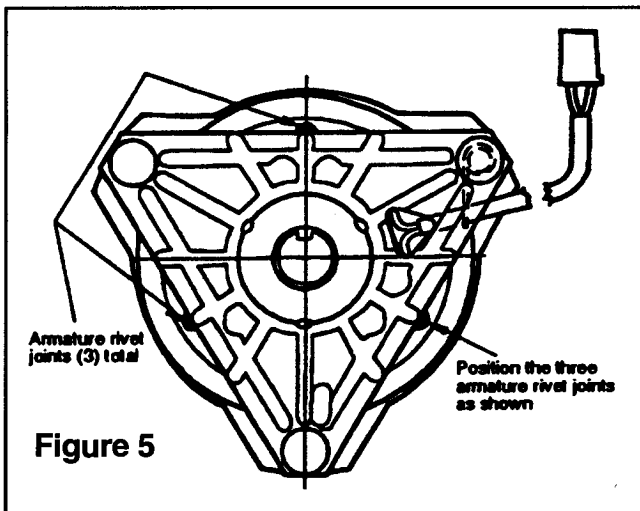

Figure 5

Positioning Rivet Joints for Airgap Adjustment

4. Rotate the pulley until these three rivet joints are located midway along the edge of the triangular adapter, or halfway between each stud. This prevents measuring the airgap over a rivet joint.
5. Turn the clutch/brake over, being careful not to disturb the orientation of the armature assembly with respect to the field.
6. Locate the three windows in the brakeplate, one at each stud.

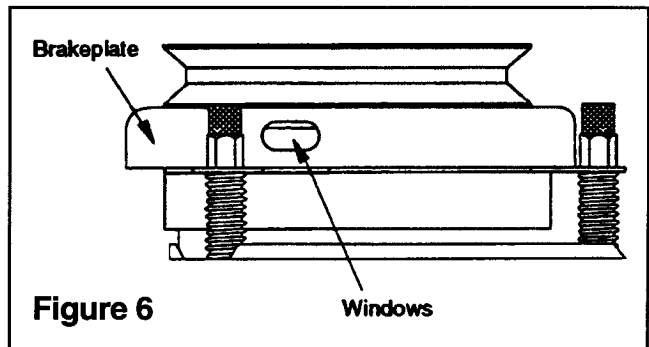

Figure 6

Windows

Location of Windows

Three per Brakeplate

7. Insert a .012" feeler gauge through each window, being careful to position the gauge between the rotor face and the armature face.

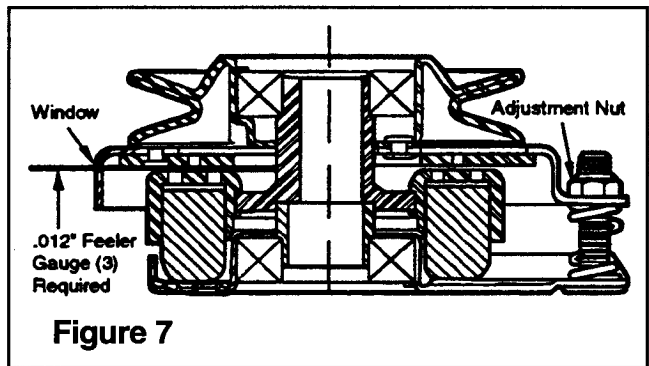

Figure 7

Setting the Airgap

8. With a three feeler gauge in place, begin to alternately tighten each nut an equal amount.
9. Tighten each nut until the feeler gauges begin to feel snug. Each gauge should require an equal amount of force for insertion and extraction.
10. Remove the feeler gauges. Turn the rotor assembly to check for rotor/armature drag. The rotor should turn freely.



ENCORE PRO-Line RIDER

11. Due to dimensional variations, the airgap between the rotor and armature may vary on a clutch from .023"/.005", even though the gap at the three windows was set at .012". This is an acceptable condition.
12. Using feeler gauges, check that the airgap does not fall between .023"/.005", repeat the above procedure. Remember: Never check the airgap directly over a joint.

Belt Adjustment

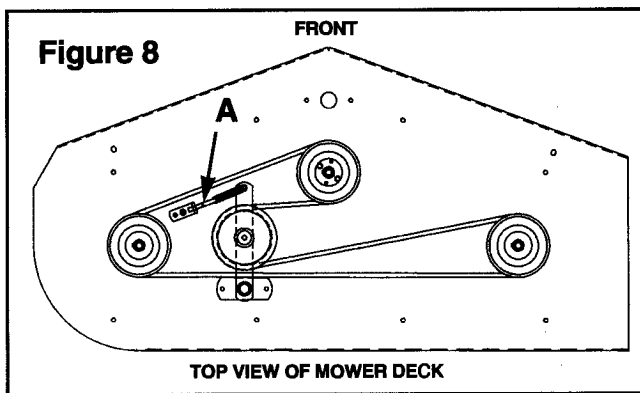

The deck belt, which can be accessed by removing the deck plate, (see figure 8) has a spring for a tensioner with a threaded rod (A) which can be adjusted or a secondary hole to hook the spring in, which will also tighten the belt. To replace the deck belt, loosen the main drive belt by loosening the two bolts at the base of the engine near the rear of the machine. To loosen the main drive belt, turn each bolt clockwise until the belt is loose enough to remove from the front deck pulley. You can then reroute the blade drive belt around the three pulleys keeping in mind the tightener must be on the back or flat side of the belt.

When tightening the main drive belt, reverse the procedure turning the bolts on the mule drive counter clockwise to compress the spring located on left hand side from 1 3/4" to 2", keep in mind that pulleys should stay on the same plane. This can be accomplished by tightening the bolts in equal amounts.

Spring should never be completely compressed; over compression is extremely dangerous and can stress the belt and bearings.

Deck Removal/Lift Assist

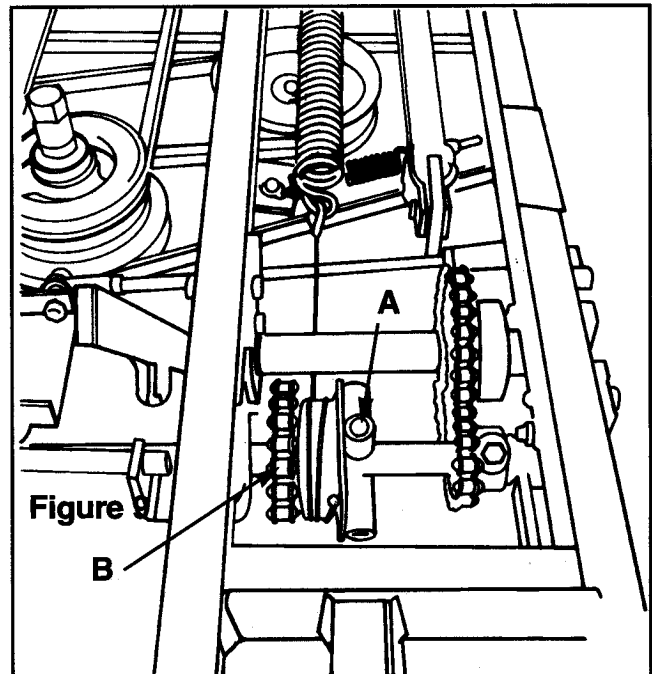

DANGER

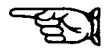

FOLLOW THESE INSTRUCTIONS CAREFULLY!

KEEP HANDS AND FACE CLEAR OF CABLE AND SPRING WHEN ADJUSTING. MAKE SURE OF A GOOD FIT FROM PUNCH TO HUB TO AVOID SLIPPING!

When adjusting deck levelers or when removing cutting deck remove the deck plate and place a 1/4 rod in the hole provided in the lift assist hub (A) (see figure 9). Apply pressure and remove the 5/16 bolt on the side of the hub (B) then let it rotate back against the frame.

Then adjust lift chains so they have equal pressure or so the deck hangs level. To replace the bolt in the hub, take slack out of chains, rotate the hub to realign bolt with hole through sprocket and reinstall bolt. Lift assist spring should be extended to about 9 1/2" in length to maintain proper tension. This should be checked with the deck in the down position.



ENCORE PRO-Line RIDER

Deck Height Adjustment

The cutting height is set at approximately 3" by the factory. You may achieve a number of other settings by removing caster spacers or adjusting carrier arms located on deck and frame. Your settings may vary with different turf conditions. For easier adjustment when changing positions on the support arms, loosen the deck drive belt.

Note: NEVER allow rear of deck to be lower than front unless cutting height is in fully raised position and you are mowing tall weeds. **THIS IS THE ONLY EXCEPTION** and will happen automatically with deck at fully raised position.

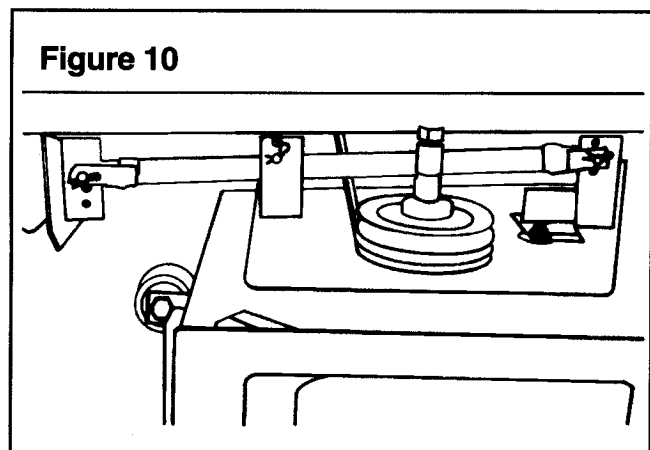

Figure 10

Approximate Settings (see figure 10)

Deck Carrying Arm Locations:

Top Hole Rear Bottom Center Middle Front

Settings:

- 0 Spacers On Front Casters2"
- 1 Spacer 2½"
- 2 Spacers3"

Deck Arm Locations:

Top Rear Bottom Center Top Front

Caster Settings:

- 2 Spacers 3"
- 3 Spacers3½"
- 4 Spacers4"

Blades

When removing blades, block front end up or run front wheels onto ramps, stop engine and place in park. Loosen the two knobs at the front of the deck and remove the deck plate. Blade bolts are equipped with "Top Lock" nuts. To remove, hold the bottom nut and turn top nut counter clockwise. When installing the nut make sure that there is about 1/8" to 1/8" space between the two nuts, then holding the bottom turn top clockwise.

To obtain optimum mowing results, mower blades should be kept sharp and well balanced. File or grind blades evenly. Take care to retain angle of original cutting edge.

CAUTION

Mower blades are sharp and can cut you during blade maintenance or adjustment. Use suitable covering over cutting edges of blade to prevent bodily harm.

Charging System

An alternator is used to charge the battery. The alternator charging system normally requires no service other than periodically checking that all exposed wiring and electrical connections on the machine are clean, tight and in good condition.

Proper polarity is critical with an alternator equipped charging system. Always disconnect battery cable (negative) before working on any part of electrical system. Verify all components are connected correctly before reconnecting ground cable (negative) or damage to alternator system components will result.

WARNING

Never run engine if battery is removed or if battery is not connected to the charging system. Serious damage to charging system components may result.



ENCORE PRO-Line RIDER

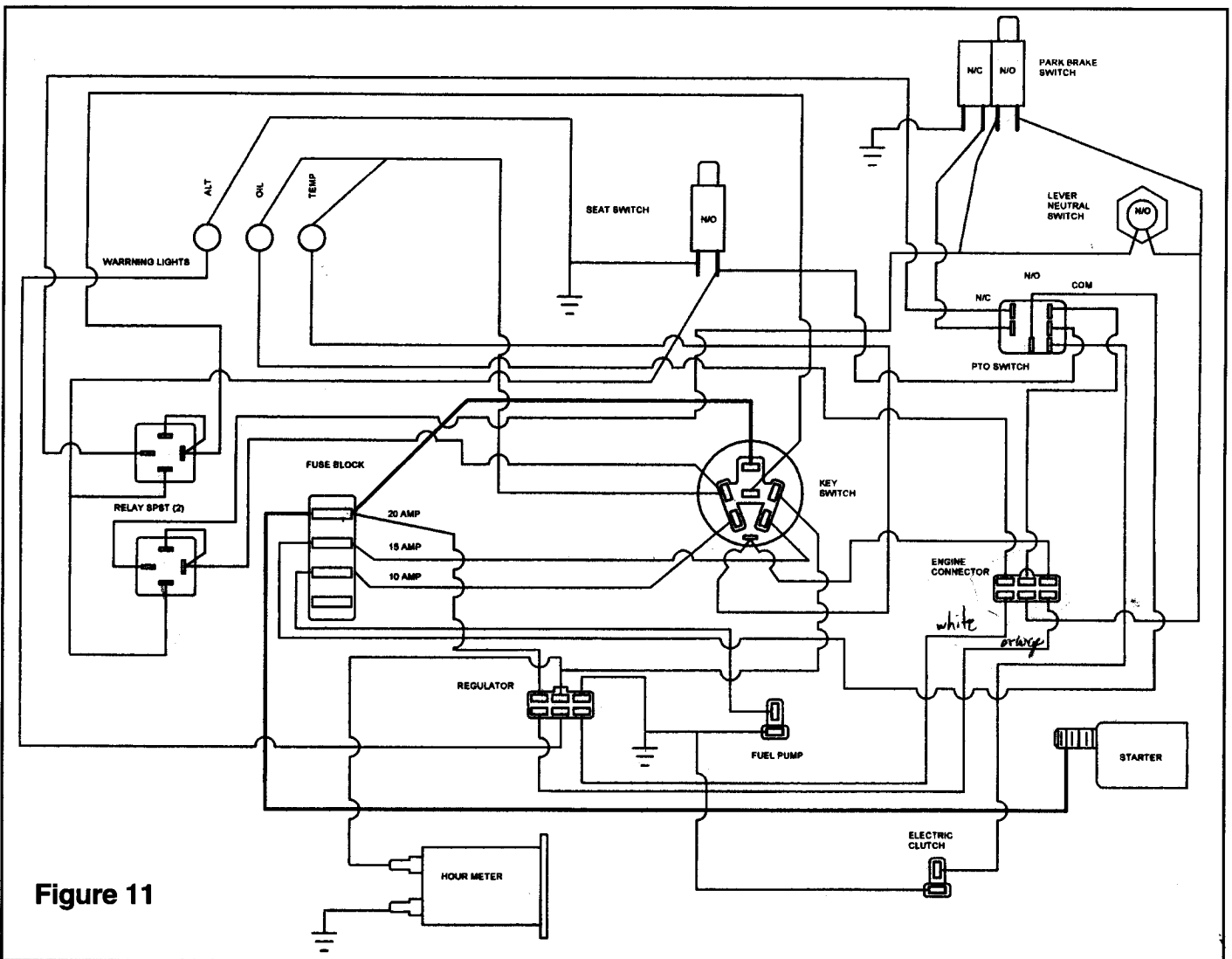

Figure 11

Electrical

The fuse box is located under the seat to the upper left of the battery on a panel mounted to the seat frame (see figure 11). There are three fuses that run the system, the top fuse, which is a 20 amp, is the main fuse. The second, a 15 amp fuse, takes care of the electric clutch. A 10 amp fuse is located in the third slot and runs the fuel pump, the fourth slot is a blank extra. If there is a reoccurring fuse failure check the electrical system for a short.



ENCORE PRO-Line RIDER

Hydrostatic Transaxle Repair Information

Eaton 751, 851, 771, and 781 series hydrostatic transaxles.

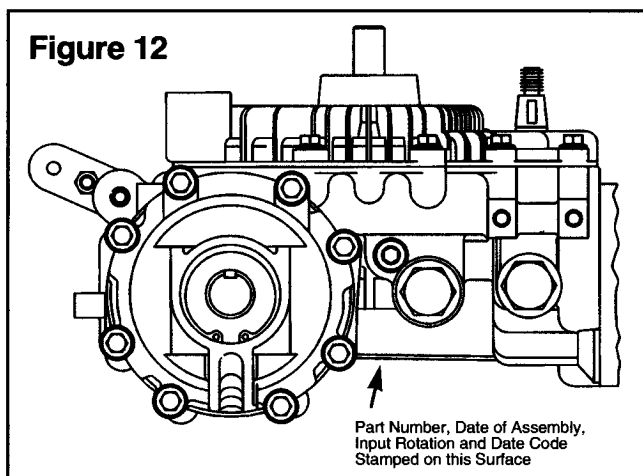

1. The transaxle identification information is located opposite the input shaft, on the back of the housing assembly.
2. The build code of the transaxles identifies the month, day and year of the transaxle manufacture. This information is found in the same area as the identification code.
3. When ordering replacement parts for a transaxle, the part(s) order must include the part name, part number, quantity of parts and also the transaxle model number, input rotation and date code.
4. The following procedures describe complete disassembly and reassembly of the transaxle. The level of cleanliness maintained while servicing the transaxle could affect its performance. Work in a clean area. After disassembly, wash all parts with clean solvent and blow the parts dry with air. Inspect all mating surfaces. Replace any damaged parts that could cause internal leakage. Do not use grit paper, files or grinders on finished parts.

Note: Whenever a transaxle is disassembled, our recommendation is to replace all seals. Lubricate the new seals with petroleum jelly before installation. Use only clean, recommended hydraulic fluid on the finished surfaces at reassembly.

5. The following tools are required for disassembly and reassembly of the transaxle.
 - $\frac{3}{8}$ " Socket or End Wrench
 - 1" Socket or End Wrench
 - Ratchet Wrench
 - Torque Wrench 300 lb-in (3 Nm)
 - $\frac{5}{32}$ Hex Wrench
 - Small Screwdriver (4" [102 mm] to 6" [150 mm])
 - No. 5 or 7 Internal Retaining Ring Pliers
 - No. 4 or 5 External Retaining Ring Pliers
 - 6" (150 mm) or 8" (200 mm) C-clamp
 - Pipe or Hydraulic Tubing (1" O.D. x 6")
 - Pipe or Hydraulic Tubing ($1\frac{1}{8}$ " [29 mm] O.D. x 6" [150 mm])
 - Small Arbor or Hydraulic Press
 - 3 or 4 Large Rubber Bands
 - Light Petroleum Jelly (such as Vaseline)
6. Seal all open ports before cleaning. Thoroughly clean the transaxle exterior.

Transaxle with Charge Pump

7. After draining the transaxle, use your hand or a liter wrench to remove the filter from the filter base.

Note: It is best to drain the transaxle through the case drain port with the input shaft in the down position.
8. Using a $\frac{3}{8}$ " socket or end wrench, remove the cap screws from the filter base, valve cover and internal filter and the port plate.

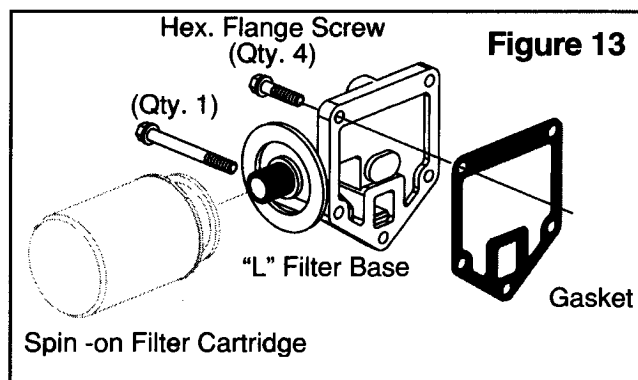

9. Remove gasket.

Note: This gasket may be on the part just removed or on the housing assembly.

ENCORE PRO-Line RIDER

Figure 14

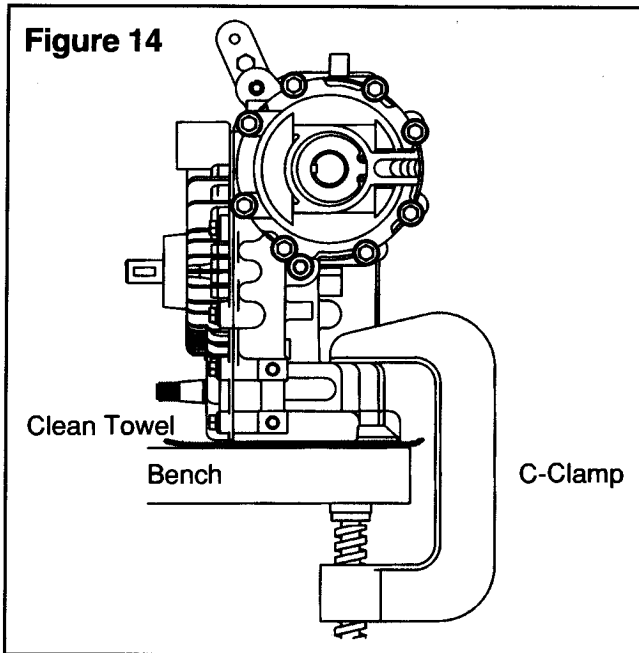

10. Position transaxle with this gasket surface toward the bench. Place a clean towel between the transaxle and the bench. The towel protects the sealing surface from possible damage during repositioning. Use a 6" (150 mm) to 8" (200 mm) C-clamp to secure the transaxle to a suitable work surface. Be careful not to overtighten the C-clamp when securing the transaxle.

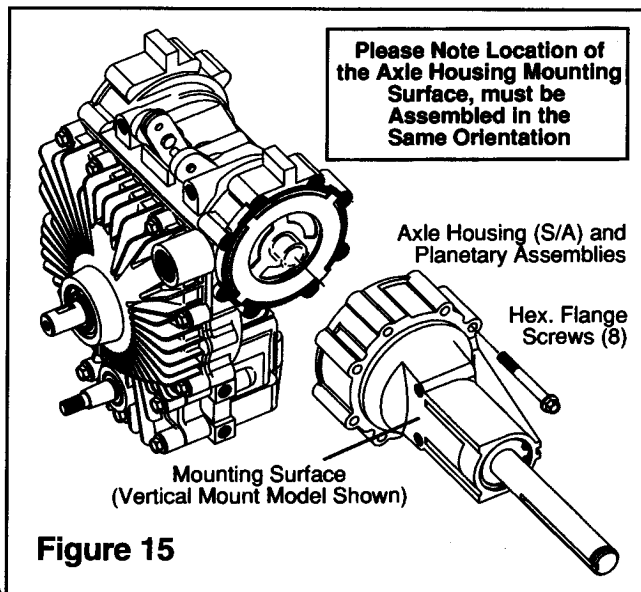

Figure 15

Axle Housing Disassembly

11. With the transaxle secure, use a $\frac{3}{8}$ " socket or end wrench to remove the flange screws from one (A-side or B-side) axle housing assembly.
12. After removing the flange screws, carefully remove the axle housing assembly from the housing assembly.

Caution: Retain the planetary assemblies in the axle housing assembly during removal.

Figure 16

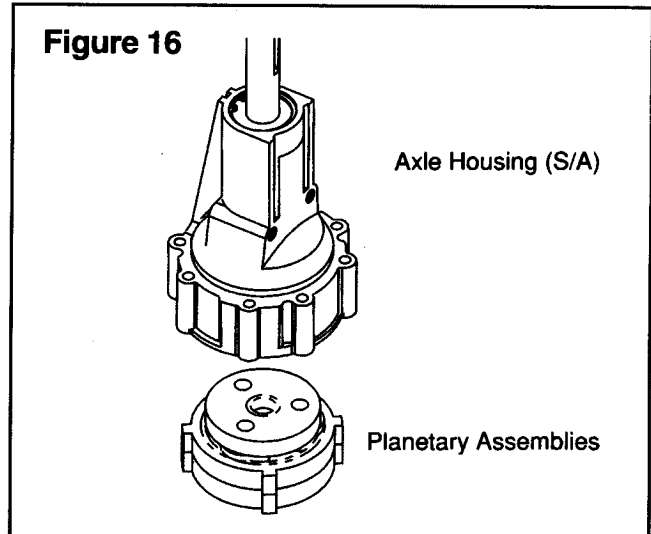

13. To disassemble the axle housing assembly, carefully position the axle housing assembly on a clean flat surface, then separate axle housing from the planetary assemblies as shown.

Figure 17

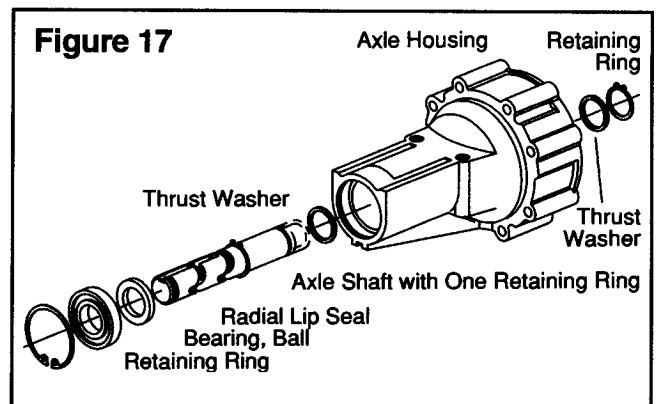

14. Position the axle housing assembly with the output end of the axle shaft in the up position. Using a No. 5 or 7 internal retaining ring pliers, remove the ball bearing retaining ring from the axle housing.



ENCORE PRO-Line RIDER

15. Reposition the axle housing with the splined end of the axle in the up position. Using a No. 4 or 5 external retaining ring pliers, remove the retaining ring and thrust washer from the axle shaft.
16. Remove the axle from the axle housing by using a small press or by tapping the splined end of the axle shaft with a plastic head hammer. This will dislodge the seal and bearing from the axle housing.
17. After separating the axle shaft from the axle housing, remove the ball bearing, seal and thrust washer from the axle shaft. The thrust washer may be in the axle housing.

Note: The retaining ring remaining on the axle shaft need not be removed.

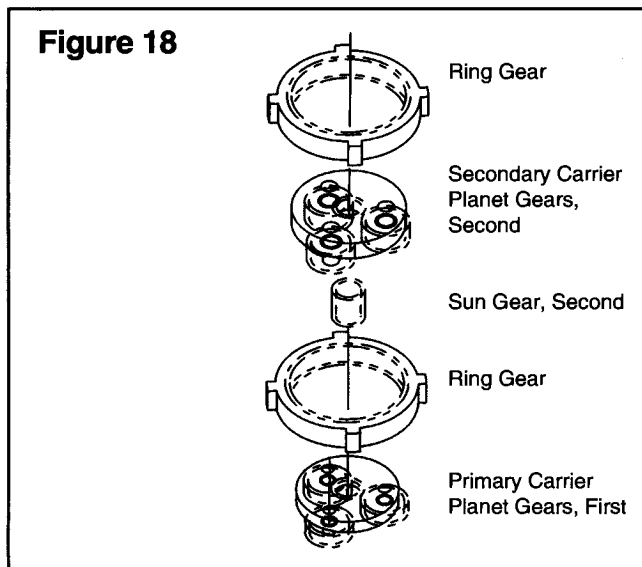

18. To disassemble the planetary assemblies for inspection and cleaning, first remove the ring gear (from the secondary carrier/planet gears).
19. Next, putting a slight squeeze on the secondary carrier planet gears. Remove the three secondary planet gears, and carrier.
20. Turn the assembly over and remove the secondary planet gears for inspection and cleaning.
21. Remove the sun gear and remaining ring gear.
22. Again, putting a slight squeeze on the remaining carrier planet gears, remove planet gears, and carrier from the backup plate.
23. Shown in Figure 18 are both the primary and secondary carrier assemblies. The planet gears may be removed for inspection and cleaning.

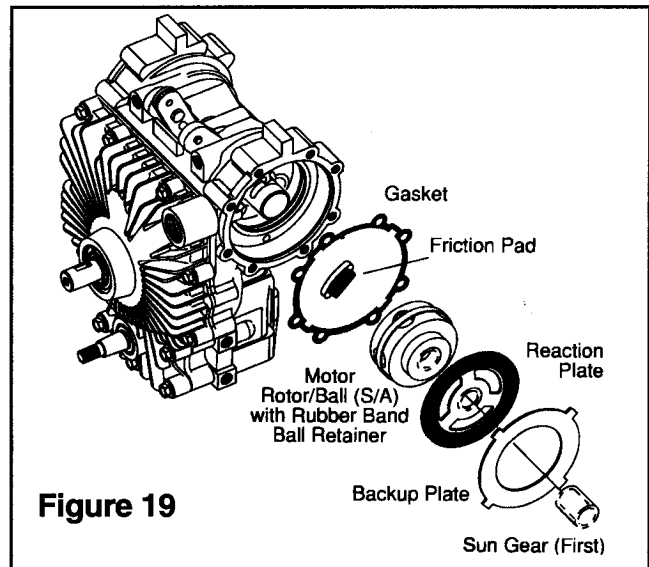

24. Next, remove the reaction plate from the primary sun gear.
25. Remove the primary sun gear from the motor rotor assembly.
26. Remove the small friction brake pad assembly from its recessed pocket located in the axle housing.
27. Shown in Figure 19 are the three major parts used in the Eaton transaxle wet brake assembly, the friction pad assembly, reaction plate and backup plate. When the brake is applied, the rotating reaction plate is squeezed between the stationary friction pad and the backup plate.
28. Remove the axle housing assembly gasket.

Note: This gasket may have remained on the axle housing.
29. Normally any further disassembly of the brake levers, push rods, etc. is not necessary not recommended. The brake lever shims located between the two brake levers are used to adjust the brake lever movement. This adjustment was made during the initial transaxle assembly.



IMPORTANT



DO NOT remove motor rotor assembly. Ball pistons are spring loaded in the bores and must remain intact because each ball piston is matched to its respective bore.

ENCORE PRO-Line RIDER

THE REMAINING TRANSAXLE HOUSING ASSEMBLY, IF APPLICABLE, CAN BE SERVICED AT THIS TIME.

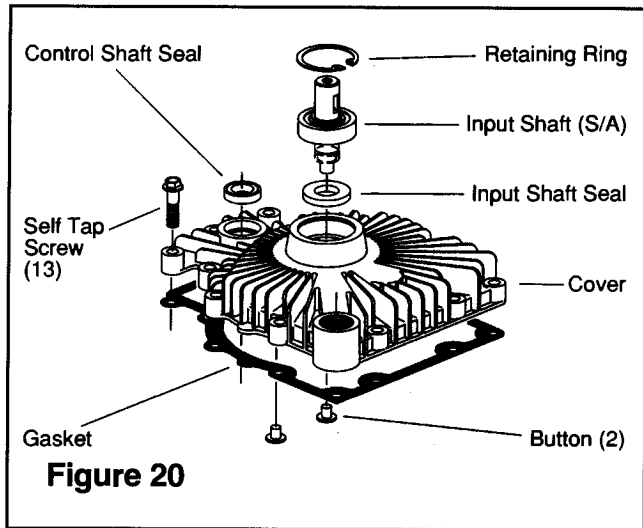

Figure 20

39. Install the cover gasket on the housing assembly.

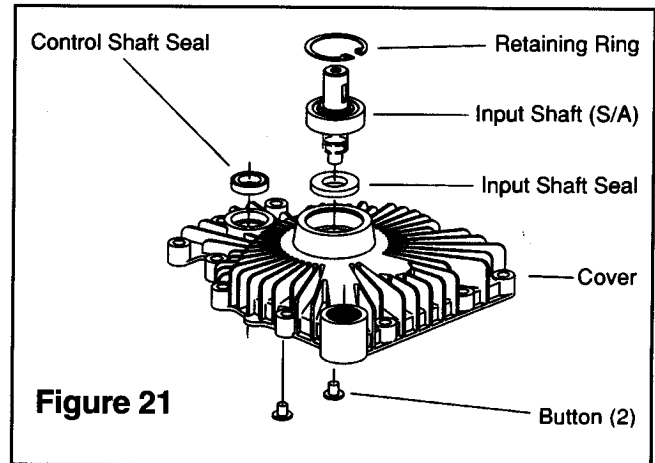

Figure 21

Cover Reassembly

40. Lubricate and install the control shaft oil seal with the seal lip pointing inward. Press or drive the seal into the seal counterbore.
41. Lubricate and install the input shaft seal with the seal lip pointing inward. Press or drive the seal into the counterbore.
42. Press or drive the input shaft assembly into the cover.
43. Install the input shaft assembly retaining ring, making sure it is firmly seated in the retaining ring groove.
44. To help retain the buttons during assembly, apply a small amount of petroleum jelly to them. Install the buttons in the holes located in the cover assembly.

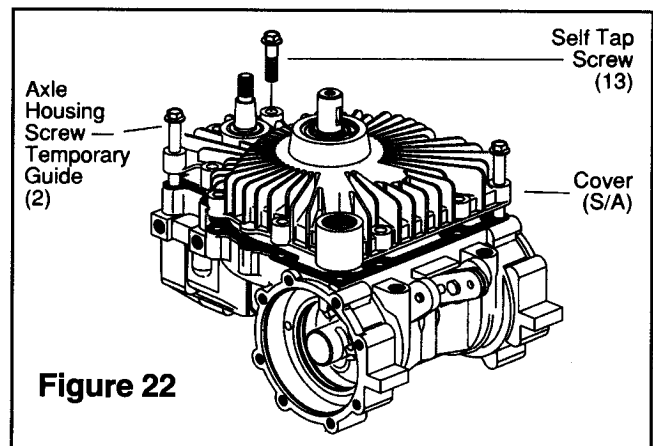

Figure 22

45. Install the cover assembly by carefully aligning it with the control shaft, cam ring pivot dowel and pump rotor drive.

30. Reposition the housing assembly. Using a $\frac{3}{8}$ " socket or end wrench, remove the self tap screws from the cover assembly.

Note: One self tap screw is located in the case drain port.
31. With all self tap screws removed (13), carefully separate and remove the cover from the housing assembly.
32. Turn the cover assembly over and remove the two buttons.

Note: These two buttons may have dropped out into the housing assembly during removal of the cover.
33. Turn the cover assembly back over and using a No. 5 or 7 internal retaining ring pliers, remove the input shaft retaining ring.
34. Reposition and support the cover allowing room for shaft removal. With the input shaft in the down position, use a plastic head hammer or press to remove the input shaft assembly from the cover.
35. No further disassembly of the shaft and bearing assembly is required as they are serviced as an assembly.
36. Using a screwdriver or similar tool, drive the input shaft seal from the cover.
37. To remove the control shaft seal, reposition the cover. Using a small screwdriver or similar tool, pry the control shaft seal from the cover.
38. Remove the cover gasket from the housing.

Note: The gasket may have remained on the cover.



ENCORE PRO-Line RIDER

Transaxle with Charge Pump



CAUTION



During installation of the cover assembly, be careful not to dislodge the charge pressure relief valve from its bore.

Note: Two axle housing flange screws may be used to help retain the cover, gasket and housing in position during assembly.

46. After engaging the control shaft and pivot dowel in the cover assembly, carefully rotate the input shaft to engage the pump rotor drive. When all mating parts are aligned and engaged, the cover assembly should fall into position on the housing assembly.

Figure 23

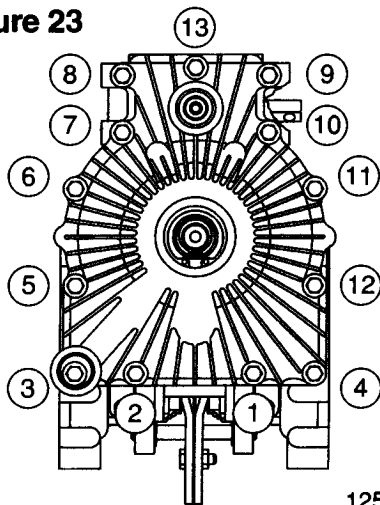

Torque
Twice in
Sequence
Shown
125 lb-in [14 Nm]

47. With the cover assembly in the proper position, remove the two alignment flange screws (if used) and install the self tap screws (13), and alternately tighten to 125 lb-in (14Nm). Torque each screw a second time to compensate for gasket compression set.

Figure 24

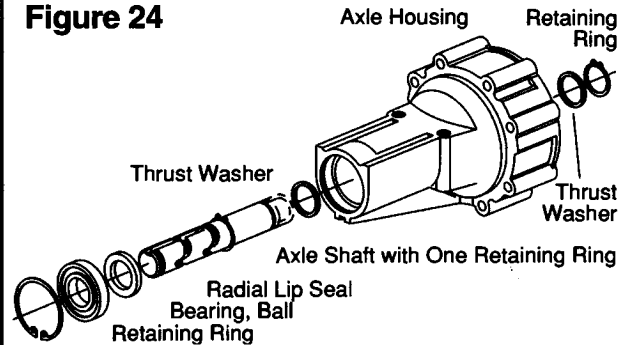

Axle Housing Reassembly (one axle housing or two, use the same procedure for each).

48. Lubricate and install the thrust washer in the axle housing.
49. Lubricate and install the axle shaft into the axle housing.
50. Reposition the axle housing with the output end of axle pointing downward. Install the inner thrust washer and axle shaft retaining ring.
- Important:** The round-cornered side or die-rolled side of the retaining ring must point toward the axle housing.
51. Reposition the axle housing with the output end pointing upward. Protecting the lip of the axle seal from the retaining ring groove and keyway, lubricate and install the seal with the lip pointing inward towards the axle housing.
52. Using a piece of pipe or hydraulic tubing (1.5" [38mm] O.D. x 6" [50mm]), press the seal into the counter-bore.
53. Again, using a piece of pipe or hydraulic tubing (1.125" [29mm] O.D. x 6" [150mm]), press the ball bearing over the axle shaft and into the axle housing.
54. Using a pair of No. 5 or 7 internal retaining ring pliers, install the ball bearing retaining ring in the axle housing.
55. Lubricate and assemble the three planetary gears on the secondary carrier assembly.

ENCORE PRO-Line RIDER

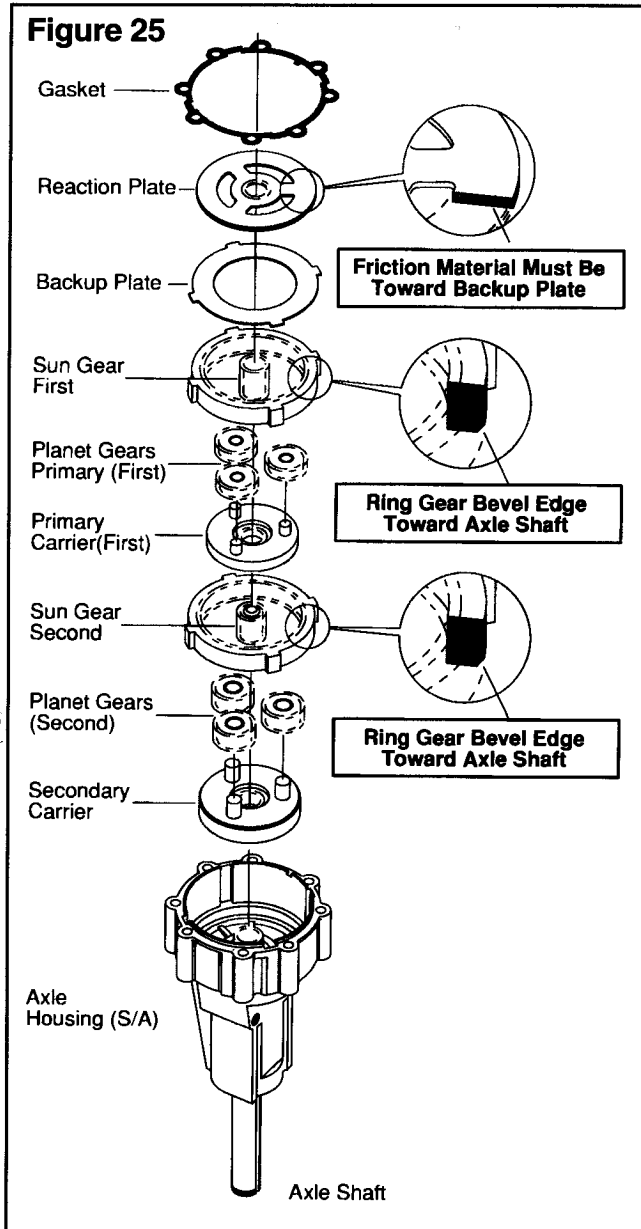

56. Aligning the splines, install the secondary carrier assembly on the splined end of the axle shaft located in the housing assembly.
57. Please note that one side of each ring gear has a bevel on one side. This bevel side of the ring gear must be toward the output end of the axle shaft.
58. Install one of the two ring gears into the axle housing. Install by aligning the ears on the outside of the ring gear with the notches in the housing assembly.
59. Rotate the secondary carrier assembly planet gears to align with the ring gear teeth. When they are all in alignment, the ring gear will fall into place.

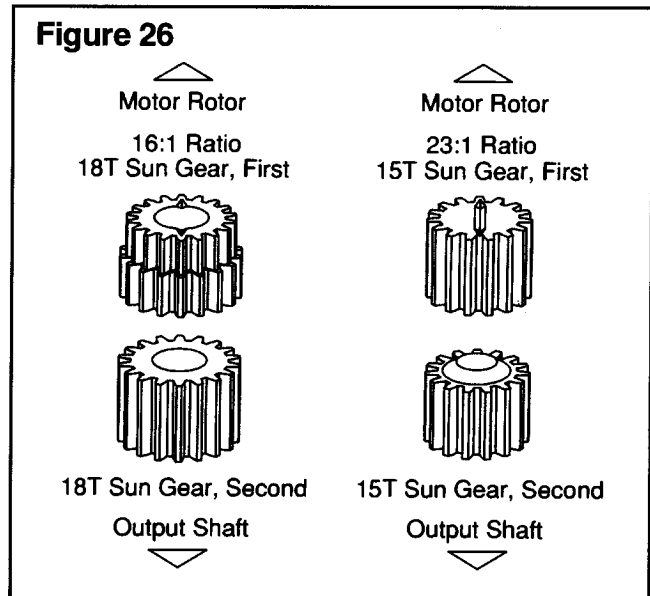

60. Shown here are the first and second sun gears for 16:1 and 23:1 gear ratios.
61. Install the sun gear (second) into the secondary planetary assembly.
62. Lubricate and assemble the three planetary gears on the primary carrier assembly.
63. Aligning the splines, install the primary carrier assembly on the sun gear (second).
64. Install the next ring gear into the axle housing. Install by again aligning the ears on the outside of the ring gear with the notches in the housing assembly.
Note: Rotate the primary carrier assembly and the ring gear will fall into position.
65. Install the primary sun gear (first) into the primary planetary assembly.
66. Lubricate and install the backup plate in the axle housing assembly. Install by aligning the ears with the notches in the axle housing.
67. Aligning the splines, install the reaction plate on the primary sun gear (friction material must be toward backup plate).
68. Aligning the screw holes and notches, install the axle housing gasket on the axle housing assembly.
69. Reposition and clamp the housing assembly to the bench as in step 10. Install the motor rotor assembly.
70. Install the friction brake pad into its recess located in the housing assembly.
71. Carefully retain the planetary assemblies in position, install the axle housing assembly on the housing assembly.
72. Install the axle housing flange screws and torque to 125 lb-in (14 Nm).



ENCORE PRO-Line RIDER

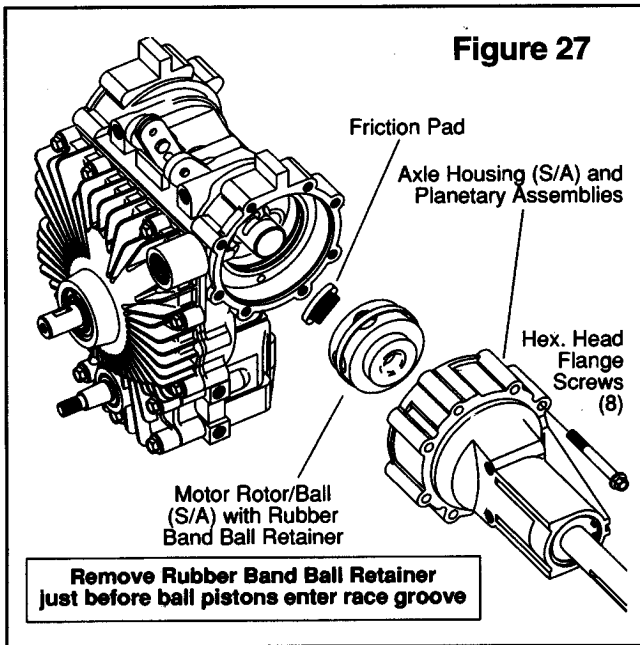

Fluid Recommendations

Premium engine oil having a viscosity of 20W-50 API.CD rating. The fluid should be chemically stable, incorporating rust and oxidation inhibitors. A reputable supplier can help you make the best selection of hydraulic fluid for use in your Eaton transaxle.

Note: If the natural color of the fluid has become black or milky, it is possible that an overheating or water contamination problem exists.

Transaxle Parts Lists

Hydrostatic Transaxle Series 751 — No. 6-425
Hydrostatic Transaxle Series 851 — No. 6-426
Hydrostatic Transaxle Series 771-A — No. 6-427
Hydrostatic Transaxle Series 771-B No. 6-428
Hydrostatic Transaxle Series 781 — No. 6-429

73. Reposition the transaxle and install the gasket and (one of the following): filter base, internal filter and valve cover (position metal side of filter toward housing and gasket), port plate.
74. Aligning the screw holes, install 5 flange screws.
75. Cross torque screws to 125 lb-in (4mm).

781 Series Transaxle

76. After servicing both transaxle halves, the two halves, center push rod, conical springs (2), bolts, washers and nuts (4 each) can be installed. Torque the bolt and nut to 16+1.6 lb-ft (22+2 Nm). Replace E-ring retaining the conical spring at each end of center push rod.

Transaxle with Charge Pump and Spin-on Filter

77. Lubricate the filter seal, install filter, hand tighten ($\frac{3}{4}$ to 1 full turn after gasket/base contact).
78. Fill transaxle with an approved hydraulic fluid (781 Series - both halves must be filled separately). The transaxle is now ready for test and installation.

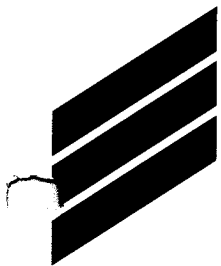

ENCORE PRO-Line RIDER

ENCORE Warranty

This warranty extends to the original retail purchaser only and commences on the date of original retail purchase.

Any part of the Encore commercial Rider manufactured by Encore Mfg. Co., Inc. and found in reasonable judgment of Encore Mfg. Co., Inc. to be defective in material or workmanship, will be repaired or replaced by an authorized Encore Mfg. Co., Inc. dealer without charge for parts and labor.

The Encore Rider, including any defective part, must be returned to an authorized Encore service dealer within the warranty period. The expense of delivering the Rider to the dealer for warranty work and the expense of returning it back to the owner after repair or replacement will be paid by the owner. Do not destroy or discard defective parts until claim has been approved. We reserve the right to request defective parts to be returned for inspection. DO NOT return parts unless requested. Should any part prove to be defective within the one year of original purchase (90 days for rental purposes), the parts will be replaced f.o.b. Beatrice, Nebraska, without charge, provided, if requested, the defective part is returned to us transportation charges prepaid. The responsibility of Encore Mfg. Co., Inc. in respect to claim is limited to making the required repairs or replacements, and no claim of breach of warranty shall be cause for cancellation or recession of the contract of sale of any Encore Rider. Proof of purchase will be required by the dealer to substantiate any warranty claim. All warranty work must be performed by an authorized Encore service dealer.

This warranty is limited to one year from the date of original retail purchase for any Encore Rider that is used for commercial purposes or 90 days rental.

This warranty does not cover any Encore Rider that has been subject to misuse, neglect, negligence, accident or that has been operated in any way contrary to the operating instructions as specified in the Operator's Manual. The warranty does not apply to any damage to the Rider that is the result of improper maintenance, or to any Rider parts that have not been assembled or installed as specified in the assembly instructions. The warranty does not cover any Rider that has been altered or modified so as to adversely affect the intended use of the product, its operation, performance or durability. In addition, the warranty does not extend to repairs made necessary by normal wear or by the use of parts or accessories which, in the reasonable judgment of Encore Mfg. Co., Inc. are either incompatible with the mower or adversely affect its operation, performance or durability. This warranty DOES NOT cover the engine and battery, which are

warranted separately by the engine and battery manufacturers and for different periods of time.

Encore Mfg. Co. Inc., reserves the right to change or improve the design of any Rider without assuming any obligation to modify any Rider previously manufactured. Encore Mfg. Co., Inc.'s obligation under the warranty is strictly and excessively limited to repair or replacement of defective parts. Encore Mfg. Co., Inc. does not assume or authorize anyone to assume for them any other obligation. Some states do not allow limitation on how long an implied warranty lasts, so the above limitation may not apply to you.

Encore Mfg. Co., Inc. assumes no responsibility for incidental, consequential or other damages including, but not limited to expense of delivering the Rider to an authorized service dealer and expense of returning it back to the owner, mechanic's travel time, telephone or telegram charges, rental of a like product during the time warranty repairs are being performed, travel, loss or damage to personal property, loss of revenue, loss of use of the Rider, loss of time or inconvenience. Some states do not allow the exclusion or limitation of incidental or consequential damages so the above limitation or exclusion may not apply to you.

This warranty gives you specific legal rights, and you may also have other rights which vary from state to state.

ENCORE MFG. CO., INC. CANNOT BE RESPONSIBLE FOR THE WAY YOU OPERATE, OR THE CONDITIONS IN WHICH YOU OPERATE THIS RIDER. USE COMMON SENSE AT ALL TIMES.

